

## Zippie® Z-Bop

**SUPPLIER:** This manual must be given to the rider of this wheelchair.

**RIDER:** Before using this wheelchair read this entire manual and save for future reference.

**Owner's Manual**

## Zippie® Z-Bop

**FOURNISSEUR:** Ce manuel doit être remis à l'utilisateur / utilisatrice de ce fauteuil roulant.

**UTILISATEUR / UTILISATRICE :** Avant d'utiliser ce fauteuil roulant, lisez entièrement ce manuel et conservez-le pour le consulter ultérieurement.

**Mode d'emploi**

## Zippie® Z-Bop

**DISTRIBUIDOR:** Este manual debe ser entregado al pasajero de esta silla de ruedas.

**PASAJERO:** Antes de usar esta silla de ruedas, lea este manual en su totalidad y guárdelo para futura referencia.

**Manual de Instrucciones**

# ZIPPIE®



**I. INTRODUCTION**

**SUNRISE LISTENS**

Thank you for choosing a Zippie wheelchair. We want to hear your questions or comments about this manual, the safety and reliability of your chair, and the service you receive from your Sunrise supplier. Please feel free to write or call us at the address and telephone number below:

**SUNRISE MEDICAL**

**Customer Service Department  
7477 East Dry Creek Parkway  
Longmont, Colorado 80503  
(800) 333-4000 or (303) 218-4500**

**FOR ANSWERS TO YOUR QUESTIONS**

Your authorized supplier knows your wheelchair best and can answer most of your questions about chair safety, use and maintenance. For future reference, fill in the following:

Supplier: \_\_\_\_\_

Address: \_\_\_\_\_  
\_\_\_\_\_

Telephone: \_\_\_\_\_

Serial #: \_\_\_\_\_ Date/Purchased: \_\_\_\_\_

**USER WARNING**

**⚠ WARNING**

Attention wheelchair users, do not operate this wheelchair without first reading the owner’s manual. If you do not understand the instructions and warnings of this owner’s manual please contact your dealer or qualified technician before operating this Quickie wheelchair. Failure to do so may result in damage and/or injury.

**DEALER/TECHNICIAN WARNING**

**⚠ WARNING**

Attention dealers and qualified technicians, do not operate or service this wheelchair without first reading this owners manual. If you do not understand the instructions and warnings of this owners manual please contact the Quickie Technical Service Department before operating and/or servicing this Quickie wheelchair. Failure to do so may result in damage and/or injury.

**⚠ WARNING**

In addition, power wheelchairs may contain printed circuit boards. Careful attention should be given to the Printed Circuit Board Handling Techniques insert supplied with the chair.

**Related Documents**

Listed below are additional documents which are referenced in this owners manual.

- Quickie QR Owners Manual
- Quickie Hand Held Programmer Owners Manual
- Quickie PC Setup-Up Station Owners Manual
- Quickie Enhanced Display Owners Manual
- Quickie Specialty Control Owners Manual

<b>II. TABLE OF CONTENTS</b>	
<b>I. INTRODUCTION</b> .....	2
<b>II. TABLE OF CONTENTS</b> .....	3
<b>III. YOUR CHAIR AND ITS PARTS</b> .....	4
<b>IV. NOTICE - READ BEFORE USE</b> .....	5
<b>V. EMI (ELECTROMAGNETIC INTERFERENCE)</b> .....	5
<b>VI. GENERAL WARNINGS</b> .....	7
A. Notice to User and Attendants .....	7
B. Weight Limit .....	7
C. Controller Settings .....	7
D. EMI .....	7
E. Safety Check-List .....	7
F. Changes & Adjustments .....	8
G. When Seated in a Parked Wheelchair .....	8
H. Environmental Conditions .....	8
I. Terrain .....	8
J. Street Use .....	8
K. Motor Vehicle Safety .....	8
L. Center of Balance .....	8
M. Transfers .....	9
N. Reaching or Leaning .....	9
O. Dressing or Changing Clothes .....	9
P. Obstacles .....	9
Q. Driving in Reverse or Moving Backward .....	9
R. Ramps, Slopes & Sidehills .....	10
S. To Reduce the Risk of Falls, Tip-over or Loss of Control .....	10
T. Ramps at Home & Work .....	10
U. Wheelchair Lifts .....	10
V. Curbs & Single Steps .....	10
W. Stairs .....	10
Z. Escalators .....	10
<b>VII. WARNINGS: COMPONENTS &amp; OPTIONS</b> .....	11
A. Anti-tip Tubes (Manual Carrier Only) .....	11
B. Armrests .....	11
C. Batteries .....	11
D. Cushions .....	11
E. Fasteners .....	11
F. Footrests .....	11
G. Motor Locks .....	11
H. On/Off Switch .....	11
I. Pneumatic Tires .....	11
J. Positioning Belts .....	12
K. Push Handles .....	12
L. Seating Systems .....	12
M. Upholstery Fabric .....	12
N. Suspension (Power Base Only) .....	12
O. Wiring .....	12
P. Manual Tilt .....	12
Q. Transit Use .....	12
R. Transit Option .....	13
S. Rear Wheel Locks .....	13
T. Modified Seat Systems .....	13
U. Anti-Tip Tubes (Rear Std) (Manual Carrier) .....	13
<b>VIII. SET UP, ADJUSTMENT &amp; USE</b> .....	14
Notes .....	14
Tools You Will Need .....	14
A. Battery Removal .....	15
B. Power Base Seat Height Adjustment .....	15
C. Power Base Seat Removal .....	15
D. Power Base Shroud Removal .....	16
E. Check-Out .....	16
F. Backrest .....	17
G. Swing-Away Hangers .....	17
H. Articulating Legrest .....	17
I. Elevating and 90° Elevating Legrest .....	17
J. Composite Footplate .....	18
K. Kids and Adult Angle Adjustable Footplate .....	18
L. Aluminum Footplate .....	18
M. 90° Footboard .....	18
N. Platform Flip-Up Footplate .....	19
O. Height Adjustable Armrests .....	19
P. Joystick and Enhanced Display .....	19
Q. To Adjust the Height of the Joystick or Enhanced Display .....	20
R. Joystick or Enhanced Display Swing-Away Retractable Mount .....	20
S. Wheel Locks .....	20
T. Anti-Tip Tubes– Rear (Manual Carrier) .....	20
U. Seat Removal .....	20
V. Manual Carrier .....	21
W. Check-Out .....	21
<b>IX. POWER BASE OPERATING GUIDE</b> .....	22
A. Circuit Breakers .....	22
B. Motor Locks .....	22
C. Performance Control Settings .....	22
D. Quickie Hand Held Programmer or Quickie PC Setup Station .....	22
E. Thermal Roll-Back .....	23
F. Circuit Breakers .....	23
G. Joystick Assembly .....	23
H. Enhanced Display .....	24
I. Motor Locks .....	24
<b>X. BATTERIES</b> .....	25
A. Introduction .....	25
B. Battery Charger .....	25
C. Acid Burns .....	25
D. Connecting Batteries in Battery Well .....	25
E. Charging Batteries .....	26
F. Disposing of Batteries .....	26
<b>XI. MAINTENANCE</b> .....	27
A. Notes .....	27
B. Cleaning .....	27
C. Storage Tips .....	27
D. Battery Maintenance .....	27
E. Pneumatic Tires .....	27
F. To Repair or Replace a Tire .....	27
G. Motor Brushes .....	28
H. Ordering Parts .....	28
I. Maintenance Chart .....	28
J. Tools You Will Need .....	28
<b>XII. SUNRISE LIMITED WARRANTY</b> .....	29
<b>FRANÇAIS</b> .....	30
<b>ESPAÑOL</b> .....	59

III. YOUR CHAIR AND ITS PARTS

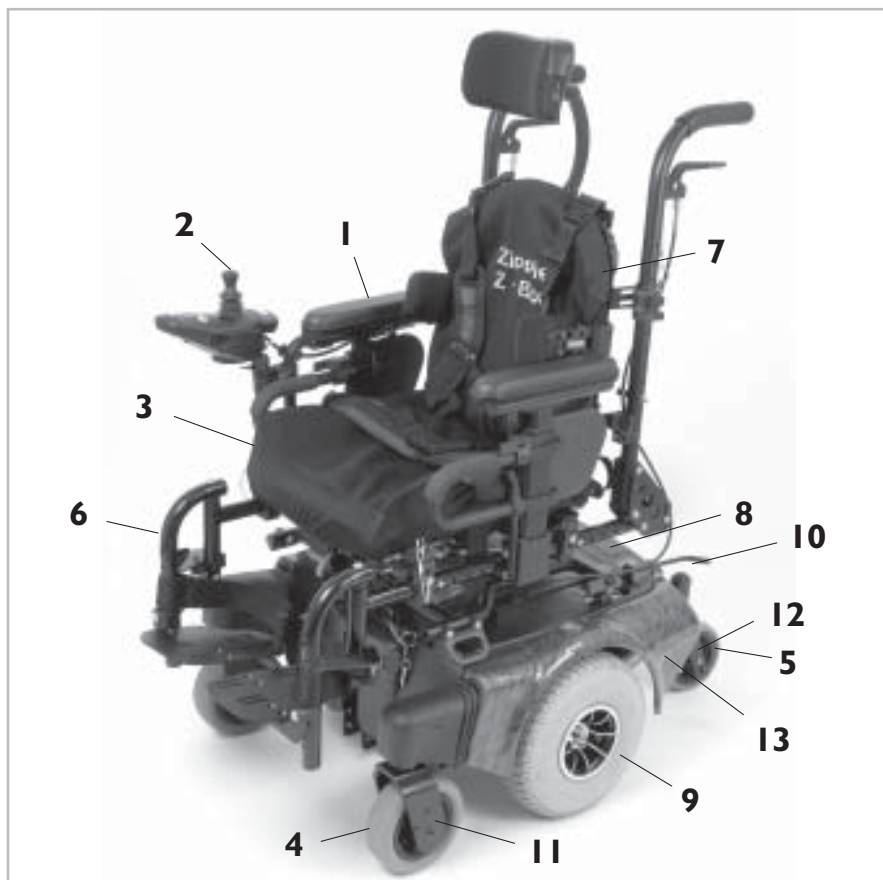

1. Single-post, height-adjustable armrest
2. Controller joystick
3. Seat frame
4. Front caster 6"
5. Rear stabilizing caster 5"
6. Swing-away with angle-adjustable footplates
7. Angle-adjustable back
8. Battery deck lid
9. 10" drive wheels
10. Freewheel release
11. Caster Fork (front)
12. Caster Fork (rear)
13. Shroud
14. Readi-align caster assist (not shown)

ZIPPIE Z-BOP

**Weight**

105 lbs (base), 35 lbs (seat)  
 140 lbs (base & seat w/out footplate or batteries)

**Drive Wheels**

10" Mag: Standard airless insert, option - pneumatic

**Joystick**

QR3-Btn (right-hand or left-hand mount)

**Batteries**

(2 deep cycle batteries required to operate chair)  
 optional UI Gel or 50 Ahr (AGM)

**Battery Charger**

Option - off board 8 AMP

**Colors (all standard)**

Standard - red, blue, champagne, black  
 Option - blue marble, pink carbon, yellow carbon

**Seat Frame**

Width: 10" - 18"  
 Depth: 13" - 20"

**Footrest**

Standard - swing-away with composite footplates and heel loops.  
 Option - elevating legrests

**Casters (front)**

Standard - 6" solid

**Casters (rear)**

Standard - 5" solid

**Armrests**

Standard - fixed height, single post  
 Height-adjust, flip back (Seat Frame)  
 Single post, height-adjustable (Seat Frame)

**Suspension**

Standard - all wheel independent

All features may not be available with some chair setups or in conjunction with another chair feature. Please consult your supplier for more information. Your authorized supplier can also provide you with more information on accessories.

## IV. NOTICE— READ BEFORE USE

## A. CHOOSE THE RIGHT CHAIR &amp; SAFETY OPTIONS

Sunrise provides a choice of many power wheelchair styles, sizes and adjustments to meet the needs of the rider. However, final selection of a wheelchair rests solely with you and your health care professional. Choosing the best chair for you depends on such things as:

1. Your size, disability, strength, balance and coordination.
2. Your intended use, and your level of activity.
3. The types of hazards you must overcome in daily use (in areas where you are likely to use your chair).
4. The need for options for your safety and comfort (such as positioning belts or special seat systems).

## B. ADJUST CHAIR TO YOUR ABILITY

You need to work with your doctor, nurse or therapist, and your supplier, to fit this chair and adjust the controller settings for your level of function and ability.

## C. REVIEW THIS MANUAL OFTEN

Before using this chair you, and each person who may assist you, should read this entire Manual and make sure to follow all instructions. Review the warnings often, until they are second nature to you.

## D. WARNINGS

The word "WARNING" refers to a hazard or unsafe practice that may cause severe injury or death to you or to other persons. The "Warnings" are in four main sections, as follows:

## 1. V — EMI

Here you will learn about electromagnetic interference and how it can affect your chair.

## 2. VI — GENERAL WARNINGS

Here you will find a safety checklist and a summary of risks you need to be aware of before you ride this chair.

## 3. VII — WARNINGS — COMPONENTS &amp; OPTIONS

Here you will learn about your chair. Consult your supplier and your health care professional to help you choose the best set-up and options for your safety.

## 4. XI — BATTERIES

Here you will learn about battery and charger safety, and how to avoid injury.

 **Q-NOTE**— Where they apply, you will also find "Warnings" in other sections of this Manual.

Throughout this owner's manual and on the wheelchair you will see the icons listed below to identify warnings and potential hazards. It is important to read and understand all of them and understand them.

 **WARNING!** These warnings must be followed, failure to do so may cause personal injury or may damage the wheelchair.

 **PROHIBITED!** Prohibited actions must never be performed. Performing an action that is prohibited can cause personal injury or may damage the wheelchair.

 **Q-NOTE:** Q-Notes are informative statements to help further explain actions, warnings or product detail.

 **ESD:** Electrostatic Discharge has a potential to damage printed circuit boards unless handled correctly. When the ESD symbol is shown throughout the owner manual, use the Proper Handling Techniques Insert supplied with the chair to properly handle printed circuit board.

## V. EMI (ELECTROMAGNETIC INTERFERENCE)

## V. EMI (ELECTROMAGNETIC INTERFERENCE)

 **WARNING**

Heed all warnings to reduce the risk of unintended brake release or chair movement:

1. **Beware of the danger from hand-held transceivers. Never turn on or use a hand-held transceiver while power to your chair is on. Use extra care if you believe that such a device may be in use near your chair.**
2. **Be aware of nearby radio or TV stations, and avoid coming close to them.**
3. **If unintended movement occurs, turn your chair off as soon as it is safe to do so.**

## A. WHAT IS EMI?

 **WARNING**

1. EMI means: electromagnetic (EM) interference (I). EMI comes from radio wave sources such as radio transmitters and transceivers. (A "transceiver" is a device that both sends and receives radio wave signals).
2. There are a number of sources of intense EMI in your daily environment. Some of these are obvious and easy to avoid. Others are not, and you may not be able to avoid them.
3. Powered wheelchairs may be susceptible to electromagnetic interference (EMI) emitted from sources such as radio stations, TV stations, amateur radio (HAM) transmitters, two way radios, and cellular phones.
4. EMI can also be produced by conducted sources or electrostatic discharge (ESD).

## B. WHAT EFFECT CAN EMI HAVE?

### WARNING

1. EMI can cause your chair, without warning, to:
  - Release its brakes
  - Move by itself
  - Move in unintended directions

**If any of these occurs, it could result in severe injury to you or others.**
2. EMI can damage the control system of your chair. This could create a safety hazard, and lead to costly repairs.

## C. SOURCES OF EMI

### WARNING

The sources of EMI fall into three broad types:

#### 1. Hand-Held Transceivers:

The antenna is usually mounted directly on the unit. These include:

- Citizens band (CB) radios
- “Walkie-talkies”
- Security, fire and police radios
- Cellular phones
- Lap-top computers with phone or fax
- Other personal communication devices

 **Q-NOTE**– These devices can transmit signals while they are on, even if not in use.

#### 2. Medium-Range Mobile Transceivers:

These include two-way radios used in police cars, fire trucks, ambulances and taxi cabs. The antenna is usually mounted on the outside of the vehicle.

#### 3. Long-Range Transceivers:

These include commercial radio and TV broadcast antenna towers and amateur (HAM) radios. Note: The following are not likely to cause EMI problems: Lap-top computers (without phone or fax), Cordless phones, TV sets or AM/FM radios, CD or tape players.

## D. DISTANCE FROM THE SOURCE

### WARNING

EM energy rapidly becomes more intense as you get closer to the source. For this reason, EMI from hand-held devices is of special concern. (See C.1) A person using one of these devices can bring high levels of EM energy very close to your chair without you knowing it.

## E. IMMUNITY LEVEL

### WARNING

1. The level of EM energy is measured in volts per meter (V/m). Every power wheelchair can resist EMI up to a certain level. This is called its “immunity level”.

2. The higher the immunity level, the less the risk of EMI. It is believed that a 20 V/m immunity level will protect the power wheelchair user from the more common sources of radio waves.
3. The configurations tested and found to be immune to at least 20 V/m are:
  - a. Zippie Z-Bop power wheelchair with a right-hand mounted Quickie controller, highback seat, flip-back armrests, solid flip-up footplate and UI gel cell batteries.
  - b. Zippie Z-Bop power wheelchair with a right-hand mounted Quickie controller, highback seat, flip-back armrests, solid flip-up footplate and 40Amh gel cell batteries.
4. The following specialty import devices have an unknown effect on the immunity level because they have not been tested on the Zippie Z-Bop with the Quickie controller:
  - Breath Control
  - Ribbon Switch
  - Disc Switch
  - Proportional Head Control
  - Proportional Mini-Joystick/Chin Control
  - Buddy Button
  - Micro Light
  - Penta Switch
  - Wobble Switch
  - ASL Head Array
  - HMC Mini-Joystick
  - Egg Switch
  - Switch-It head Array

### WARNING

Individuals with physical limitations requiring the use of a specialty control input device known not to be immune to 20V/m, or not known, should exercise extra care around known sources of EMI.

### WARNING

There is no way to know the effect on EMI if you add accessories or modify this chair. Any change to your chair may increase the risk of EMI. Parts from other suppliers have unknown EMI properties.

## F. REPORT ALL SUSPECTED EMI INCIDENTS

### WARNING

You should promptly report any unintended movement or brake release. Be sure to indicate whether there was a radio wave source near your chair at the time. Contact: Sunrise Medical Customer Service Department at (800) 333-4000.

## VI. GENERAL WARNINGS

**⚠ WARNING**

Heed all warnings in this section. If you fail to do so a fall, tip-over or loss of control may occur and cause severe injury to you or others.

## A. NOTICE TO USER AND ATTENDANTS

**⚠ WARNING**

## User

1. Before using this chair, you should be trained in its safe use by your health care professional.
2. Every wheelchair is different. Take the time to learn the feel of this chair before you begin riding.
3. Be aware that you must develop your own methods for the safe use of this chair, that are best suited to your level of function and ability.
4. Have someone help you practice bending, reaching and transfers until you learn how to do them safely.
5. Never try a new maneuver on your own unless you are sure it is safe.
6. Get to know the areas where you plan to use your chair. Look for hazards and learn how to avoid them.
7. Always wear a positioning strap.
8. Do not use a wheelchair if the joystick does not spring back to the neutral position.
9. Do not use your wheelchair if the joystick boot is ripped or damaged.
10. Do not try to tip this wheelchair without an attendant present.

## User and Attendants

1. When transferring the user in or out of the wheelchair never use the footplate as a platform.
2. Do not lift this wheelchair by any parts that are removable, doing so may result in damage to the wheelchair or injury to the user.
3. Never try to stop or slow this wheelchair with the wheel locks (if applicable). Wheel locks are designed to prevent the chair from moving when stopped. They are not brakes.
4. Always keep your hands and body parts clear of moving parts to help prevent injuries.

## Attendants

**⚠ WARNING**

Make sure you heed all warnings and follow all instructions in each section of this manual. Be aware that warnings that apply to the user also apply to you.

1. Do not stand or sit on any portion of this wheelchair.
1. You need to work with the user, and the user's doctor, nurse or therapist, to develop safe methods best suited to your abilities and those of the user.
2. To manually push the chair you must release the motor locks.
  - Make sure you have full control over the chair when you release the motor locks. When you do so the chair will not have brakes.
  - Make sure the chair is on level ground before you release the motor locks.

## B. WEIGHT LIMIT

**⚠ WARNING**

1. NEVER exceed the weight limit of 165 pounds (74.8 kilograms), for combined weight of rider and items carried.
2. Never use this chair for weight training if the total weight (rider plus additional weights) exceeds the weight limits outlined above.
3. Exceeding the weight limit is likely to damage the seat, frame, or fasteners and may cause severe injury to you or others from chair failure.
4. Exceeding the weight limit will void the warranty.

## C. CONTROLLER SETTINGS

**⚠ WARNING**

Be aware that you may need to adjust the controller settings of your chair to reduce the risk of a collision, fall or tip-over.

1. Check and adjust the settings every six to twelve months (or more often, if needed).
2. Consult your supplier to adjust the control settings immediately if you notice any change in your ability to:
  - Control the joystick.
  - Hold your torso erect.
  - Avoid running into objects.

## D. EMI

**⚠ WARNING**

Read Section V to learn about EMI. To reduce the risk of unintended brake release or chair movement:

1. Never turn on or use a hand-held transceiver while power to your chair is on. Use extra care if you believe that such a device may be in use near your chair.
2. Be aware of nearby radio or TV stations, and avoid coming close to them.
3. If unintended movement or brake release occurs, turn your chair off as soon as it is safe.

## E. SAFETY CHECK-LIST

**⚠ WARNING**

## Before each use of this chair:

1. Make sure the chair operates smoothly. Check for noise, vibration, or a change in ease of use. (They may indicate low tire pressure, loose fasteners, or damage to your chair). If you detect a problem, make sure to repair or adjust the chair. Deferring repair or adjustment could increase the risk for injury. Your supplier can help you find and correct the problem.
2. Make sure batteries are charged. Green lights on charge indicator will light up when charge is full. Yellow lights indicate battery charge level is getting low. Red lights indicate batteries are in immediate need of charging.
3. If your chair has anti-tip tubes, lock them into place (manual carrier only).

## F. CHANGES & ADJUSTMENTS

### WARNING

Never use non-Zippie parts or make changes to your chair unless authorized by Sunrise. (Doing so will void the Warranty and may create a safety hazard).

1. If you modify or adjust this chair it may increase the risk of a fall or tip-over.
2. Modifications to the chair, seating system, or other components which are unauthorized by Sunrise constitutes remanufacturing of the wheelchair. This voids the warranty. The rider then assumes all future liability for the wheelchair.
3. We recommend that you use anti-tip tubes until you adopt to the change and are sure you are not at risk to tip over (manual carrier only).

## G. WHEN SEATED IN A PARKED WHEELCHAIR

### WARNING

1. Always turn off all power to your chair when you are parked, even for a moment. This will prevent:
  - Accidental movement from contact with the joystick by you or others.
  - Unintended brake release or movement from EMI sources. (See Section V)
2. Make sure that persons who help you (for example, store clerks) are aware of the joystick and do not touch it. If they do, your chair may move suddenly when you do not expect it.

## H. ENVIRONMENTAL CONDITIONS

### WARNING

Your chair is not designed for use in a heavy rain storm, or in snowy or icy conditions.

1. Contact with water or excessive moisture can cause an electrical malfunction. The frame, motors and other chair parts are not watertight and may rust or corrode from the inside. To avoid a chair failure:
  - Minimize exposure of your chair to a rain storm or very wet conditions.
  - Never take your chair into a shower, tub, pool or sauna.
  - Do not use your chair in fresh or salt water (such as at the edge of a stream, lake, or ocean).
  - Make sure shroud cover and deck lid are secure.
  - Replace joystick boot if it becomes torn or cracked.
  - Make sure all electrical connections are secure.
  - Dry the chair as soon as you can if it gets wet, or if you use water to clean it.
2. Proceed slowly and use extra care if you must operate your chair on a wet or slick surface.
  - Do so only if you are sure it is safe.
  - Stop if one or both main wheels lose traction. If this occurs, you may lose control of your chair or fall.
  - Never operate your chair on a slope or ramp if there is snow, ice, water or oil film present.
  - When in doubt, have someone help you.
3. When not in use, keep your chair in a clean, dry place.

### WARNING

Extra caution should be used when employing the disc switch or the proximity head array as control devices. These two devices are susceptible to malfunction when wet.

## I. TERRAIN

### WARNING

1. This chair is designed for use on firm, even surfaces such as concrete, asphalt and indoor flooring.
2. Do not operate your chair in sand, loose soil or over rough terrain. Doing so may damage wheels, bearings, axles or motors, or loosen fasteners.

## J. STREET USE

### WARNING

In most states, power chairs are not legal for use on public roads. Be alert to the danger of motor vehicles on roads or in parking lots.

1. At night, or when it is hard to see, use reflective tape on your chair and clothing.
2. It may be hard for drivers to see you. Make eye contact with drivers before you proceed. When in doubt, yield until you are sure it is safe.

## K. MOTOR VEHICLE SAFETY

### WARNING

To date, the U.S. Department of Transportation has not approved any tie down system for transporting this wheelchair in a motor vehicle.

1. Never sit in this chair while in a moving vehicle. In an accident or sudden stop you may be thrown from the chair.
  - **Wheelchair belts are designed to position the rider only and will not protect you in an accident; further injury may result from the belts.**
2. Always move to an approved vehicle seat. You must be secured with proper motor vehicle restraints.
3. Never transport this chair in the front seat of a vehicle. It may shift and interfere with the driver.
4. Always secure this chair so that it cannot roll or shift.

## L. CENTER OF BALANCE

### WARNING

The point where this chair will tip forward, back or to the side depends on its center of balance and stability.

#### The Center Of Balance Is Affected By:

1. The seat height and seat angle.
2. A change in your body position, posture or weight distribution.
3. Using this chair on a ramp or slope.
4. The use of a back pack or other options, and the amount of added weight.

#### To Reduce The Risk Of A Fall Or Tip-Over:

1. Consult your supplier for information on modifications authorized by Sunrise before you modify or adjust this chair.



**Q-NOTE**– You may need to make additional changes to correct the center of balance.

2. Use extreme care until you know the balance points of this chair and how to avoid a fall or tip-over.
3. Use anti-tip tubes (manual carrier).
4. have someone help you until you know the balance points of your chair and how to avoid tip-over.

## M. TRANSFERS

### WARNING

**It is dangerous to transfer on your own. It requires good balance and agility. Be aware that there is a point during every transfer when the wheelchair seat is not below you. To avoid a fall:**

1. Always turn off power before you transfer to or from your chair. If you fail to do so you may touch the joystick and cause your chair to move when you do not expect it.
2. Make sure motor locks are engaged. This keeps the chair from moving when you transfer.
3. Work with your health care professional to learn safe methods.
  - Learn how to position your body and how to support yourself during a transfer.
  - Have someone help you until you are sure you can do a safe transfer on your own.
4. Move your chair as close as you can to the seat you are transferring to. If possible, use a transfer board.
5. Rotate the front casters until they are as far forward as possible.
6. Be careful of the foot platform. If you can, remove or swing it out of the way.
  - Never stand on footrests when you transfer. Doing so may damage them or cause your chair to tip.
  - Make sure your feet do not "hang up" or get caught in the space between the footrests.
7. Make sure armrests do not interfere.
8. Transfer as far back onto the seat surface as you can. This will reduce the risk that you will miss the seat or fall.

## N. REACHING OR LEANING

### WARNING

**Reaching or leaning affects the center of balance of your chair. If done improperly, a fall or tip-over is likely. When in doubt, ask for help or use a device to extend your reach.**

#### **To Reduce the Risk of injury and/or Damage to the Chair:**

1. Never reach or lean if you must shift your weight sideways or rise up off the seat.
2. Never reach or lean if you must move forward in your seat to do so. Always keep your buttocks in contact with the backrest.
3. Never reach with both hands (you may not be able to catch yourself to prevent a fall if you lose your balance).
4. Never try to pick up an object from the floor by reaching down between your knees.
5. Never put pressure on the footrest while reaching. This may cause the chair to tip if you lean too far.
6. Never reach or lean over the top of the seat back. This may damage the backrest and cause you to fall.
7. Never reach or lean to the rear unless your chair has anti-tip tubes locked in place (manual carrier).

## IF YOU MUST REACH OR LEAN, DO SO AT YOUR OWN RISK.

### **Remember to:**

1. Move your chair as close as you can to the object you wish to reach.
2. Rotate the front casters until they are as far forward as possible. This makes the chair more stable.



**Q-NOTE**– *To do this: Move your chair past the object you want to reach, then back up alongside it. Backing up will rotate the casters forward.*

3. Turn off all power to your chair. If you fail to do so, you may touch the joystick and cause your chair to move when you do not expect it.
4. Firmly grasp an armrest with one hand. This will help to prevent a fall if the chair tips.

## O. DRESSING OR CHANGING CLOTHES

### WARNING

**Be aware that your weight will shift if you dress or change clothes while seated in this chair. To make the chair more stable, rotate the front casters until they are forward and lock anti-tip tubes in place when applicable.**

## P. OBSTACLES

### WARNING

**Obstacles you may have to overcome in daily use include door thresholds, lifts, ramps and hazards such as potholes and broken pavement. These can damage your chair and may cause a fall, tip-over or loss of control.**

1. Be aware that thresholds are very dangerous. (Even a small change in height may stop a caster wheel and cause your chair to tip). You may need to:
  - Remove or cover threshold strips between rooms.
  - Install a ramp at entry or exit doors.
2. Keep your eyes moving when you ride; scan the area well ahead of your chair.
3. Make sure the floor areas where you use this chair are level and free of obstacles.
4. To help correct your center of balance:
  - Lean your upper body forward slightly as you go up over an obstacle.
  - Press your upper body backward as you go down from a higher to a lower level.
5. If your chair has anti-tip tubes, lock them in place before you go up over an obstacle.

## Q. DRIVING IN REVERSE OR MOVING BACKWARD

### WARNING

**Use extra care when you drive your chair in reverse. You may lose control or fall if one of the rear wheels hits an object.**

1. Operate your chair slowly and at an even speed.
2. Stop often and check to make sure your path is clear of obstacles.
3. If your chair has anti-tip tubes, make sure to lock them into place.

## R. RAMPS, SLOPES & SIDEHILLS

### WARNING

The center of balance of your chair changes when you are on a slope.

 **Q-NOTE**– “Slope” includes a ramp or sidehill. Your chair is less stable when it is at an angle. Never use this chair on a slope unless you are sure it is safe. When in doubt, have someone help you.

#### Beware Of:

1. Steep slopes. Do Not use this chair on a slope steeper than 10%. (A 10% slope means one foot in elevation for every ten feet of slope length.)
2. Wet or slippery surfaces (such as when ice, snow, water or oil film is present). A loss of traction may cause a fall or tip-over.
3. A change in grade on a slope (or a lip, bump or depression). These may cause a fall or tip-over.
4. A drop-off at the bottom of a slope. (A drop-off of as small as 3/4 inch can stop a front caster and cause the chair to tip forward).

## S. TO REDUCE THE RISK OF A FALL, TIP-OVER OR LOSS OF CONTROL

### WARNING

1. Never use your chair on a slope unless you are sure you can do so without losing traction.
2. Always go as straight up and as straight down as you can.
  - Do not “cut the corner” on a slope or ramp.
  - Do not turn or change direction on a slope.
3. Always stay in the center of the ramp. Make sure ramp is wide enough that you are not at risk that a wheel may roll off the side.
4. Lean or press your body uphill. This will help adjust for a change in the center of balance caused by the slope.
5. Keep your chair moving at a slow, steady speed. Keep control over the chair at all times.
  - On a descent, do not let your chair accelerate beyond its normal speed.
  - If the chair picks up speed, center the joystick to slow down or stop.
  - If you stop, re-start slowly.

## T. RAMPS AT HOME & WORK

### WARNING

Make sure ramps meet all Building Codes for your area.

1. For your safety, have a licensed contractor build or remodel ramp to meet all standards.

 **Q-NOTE**– The proper design will vary, depending on such things as: the length and height of the ramp; the need for an intermediate platform; landing size; doors and the direction of swing; and whether the ramp includes a turn or angle.

#### At A Minimum:

1. Open sides of ramp must have side rails to prevent your chair from going over the edge.
2. Slope must not be steeper than one inch in height for every one foot of slope length.
3. Ramp surface must be even, and have a non-skid surface.
4. You may need to add a section at the top or bottom to avoid a lip or drop-off.
5. Ramp must be sturdy. Add bracing if needed, so ramp does not “bow” when you ride on it.

## U. WHEELCHAIR LIFTS

### WARNING

Wheelchair lifts are used in vans, buses, and buildings to help you move from one level to another.

1. Always turn off all power to your chair when you are on a lift. If you fail to do so, you may touch the joystick by accident and cause your chair to drive off the platform. (Be aware that a “roll-stop” at the end of the platform may not prevent this).
2. Make sure there is not a lip or drop-off at the top or bottom of the platform. These may cause a fall or tip-over. When in doubt, have someone help you.
3. Always secure the rider with a positioning belt to help prevent falls during transfers.
4. Avoid moving forward if a wheel is “hung up” on the lip of the ramp. Backup, reposition the caster for a more direct approach and slowly try again.

## V. CURBS & SINGLE STEPS

### WARNING

1. It is recommended to climb and/or descend a curb, single step, or other obstacle that a ramp or curb cutout is always used.
2. If you must climb or descend a curb, single step, or other obstacle that is greater than 2.5", it is recommended to have a person assist you in doing so.
3. In no case should you try to climb a curb, single step, or other obstacle greater than 4" high.
4. If you must climb or descend a curb or step alone do so at your own risk using extreme care and follow the following procedure:
  - Proceed slowly, at a steady speed
  - Go as straight up or down as you can over the obstacle. Never turn when trying to climb or descend and obstacle, doing so may result in a fall or tip-over.
5. Failure to follow the above procedures may cause:
  - A Fall or Tip Over
  - Damage to the frame, wheels, axles or other parts, or loose fasteners.

## W. STAIRS

### WARNING

Never use this chair to go up or down stairs, even with an attendant. Doing so is likely to cause a fall or tip-over.

## X. ESCALATORS

### WARNING

Never take this chair on an escalator, even with an attendant. Doing so is likely to cause a fall or tip-over.

## VII. WARNINGS: COMPONENTS &amp; OPTIONS

**⚠ WARNING**

**Note: If you use parts or make changes not authorized by Sunrise it may create a safety hazard and will void the Warranty.**

**A. ANTI-TIP TUBES**

(manual carrier only)

Never remove or alter anti-tip tubes. They help keep your chair from tipping over backward in normal use. Make sure rubber rollers are in good condition.

**B. ARMRESTS****⚠ WARNING**

**Armrests cannot be used to lift chair or the seat.**

**🚫 PROHIBITED!**

1. Never lift this chair by its armrests.
2. Lift this chair only by non-detachable parts of the main frame.

**C. BATTERIES****⚠ WARNING**

1. Only deep cycle sealed case construction batteries should be used in this device.
2. To prevent an acid spill, always keep batteries upright (wet cell batteries only).

**🚫 PROHIBITED!**

1. Never smoke or hold an open flame near batteries. They are a known explosion hazard.
2. Always wear rubber gloves and safety glasses when you handle batteries.
3. Read all of section XI Batteries before attempting to change or charge batteries.
4. Always remove batteries using straps or handle provided. Pinched fingers may occur if the batteries are removed by grasping the battery casings.

**D. CUSHIONS****⚠ WARNING**

If you suffer from pressure sores, or if you are at risk that they will occur, you may need a special seat system such as can be provided by the Seat Frame, or a device to control your posture.

- Consult your doctor, nurse or therapist to find out if you need such a device for your well-being.

**E. FASTENERS****⚠ WARNING**

**Many of the screws, bolts and nuts on this chair are special high-strength fasteners. Use of improper fasteners may cause your chair to fail.**

1. Only use fasteners provided by Sunrise.
2. If fasteners become loose, tighten them as soon as you can.
3. Over- or under-tightened fasteners may fail or cause damage to chair parts.
  - See Section IX, "Set-Up, Adjustment & Use", for proper torque settings.

**F. FOOTRESTS****⚠ WARNING**

1. At the lowest point, the foot platform and footrests should be at least 2 1/2" off the ground. If set too LOW, it may "hang up" on obstacles you can expect to find in normal use. This may cause the chair to stop suddenly and tip forward.
2. To avoid a trip or fall when you transfer:
  - Make sure your feet do not "hang up" or get caught in the space surrounding or in between the footrests.
  - Avoid putting weight on the footrests, as the chair may tip forward.
  - Swing the footrests out of the way, if possible.

**🚫 PROHIBITED!**

3. Never lift this chair by the footrests. Footrests fold or detach and will not bear the weight of this chair. Lift this chair only by non-detachable parts of the main frame.

**G. MOTOR LOCKS****⚠ WARNING**

1. Do not engage or disengage motor locks unless power to the chair is off.
2. Be aware that the chair will not have brakes when motor locks are in the free-wheel position, unless the chair is equipped with optional power base wheel locks.
3. Make sure that the person pushing the chair has full control when motor locks are disengaged.

**H. ON/OFF SWITCH****⚠ WARNING**

1. Never use the ON/OFF switch to stop the chair except in an emergency. This will result in an abrupt stop and may cause you to fall.
2. To slow your chair to a stop, return the joystick to neutral.

**I. PNEUMATIC TIRES****⚠ WARNING**

**Proper inflation extends the life of your tires and makes your chair easier to use.**

1. Do not use this chair if any of the tires are under- or over-inflated. Check weekly for proper inflation level, as listed on the tire sidewall.
2. Low pressure in a tire may cause the chair to veer to one side and result in a loss of control.
3. An over-inflated tire may burst.
4. Never use a gas station air pump to inflate a tire. Such pumps provide air at high volume, and could cause the tire to burst. To prevent tire damage:
  - Use a hand pump (or a low volume air pump) to inflate tires.
  - Use a tire gauge to check pressure.
5. Driving over sharp objects may cause damage to pneumatic tires and tubes.

## J. POSITIONING BELTS

### WARNING

Use a positioning belt only to help support your posture. Improper use of such belts may cause severe injury or death.

1. Make sure you are not at risk to slide down in the wheelchair seat. If this occurs, you may suffer chest compression or suffocate due to pressure from the belt.
2. A pelvic wedge or a similar device can help you from sliding down in the seat. Consult your health care professional to find out if you need such a device.
3. The belt must be snug, but must not be so tight that it interferes with breathing. You should be able to slide your open hand, flat, between the belt and your stomach.
4. Make sure you can easily remove the belt in an emergency.
5. Never use a positioning belt:
  - In place of a motor vehicle seat belt. In an accident or sudden stop you may be thrown from the chair. A positioning belt will not prevent this, and further injury may result from the belt.
  - As a restraint. A restraint requires a doctor's order.
  - On a rider who is comatose or agitated.

## K. PUSH HANDLES (seat frame only)

### WARNING

1. Push handles provide secure points for an attendant to propel and control the chair. This helps to prevent a fall or tip-over.
2. Check to make sure push handle grips will not rotate or slip off.

## L. SEATING SYSTEMS

### WARNING

1. Use of a seating system not approved by Sunrise may alter the center of balance of this chair. This may cause a fall or tip-over.
2. Never change the seating system of your chair unless you consult your supplier first.

## M. UPHOLSTERY FABRIC

### WARNING

1. Replace worn or torn fabric of the seat as soon as you can. If you fail to do so, the seat may fail and cause you to fall. Worn fabrics may increase the potential for a fire hazard.
2. Fabric will deteriorate with age and use. Look for fraying, thin spots, or stretching of fabric at rivet holes. Replace fabric as required.
3. Be aware that washing may reduce flame retardation of the fabric.

## N. SUSPENSION (Power base only)

### WARNING

The suspension system does contain **Dry Natural Rubber**. The suspension, or any other component on the chair, does not contain any latex based product. The suspension components are enclosed and inaccessible to the user.

## O. WIRING

### WARNING

Never pull on cables directly. This can result in wires breaking inside the connector or harness. To remove a plug or connector, always grasp the plug or connector itself.

## P. MANUAL TILT

### WARNING

#### 1. Operation

- While driving this wheelchair in the tilted position use caution.
- Do Not attempt to operate the tilt while positioned on an incline.

#### 2. Pinch points

Pinch points may occur when operating the tilt on this chair. Ensure all hands and body parts are clear of all tilt components that may result in pinch points before operating the tilt.

#### 3. Maximum User Weight

Do not exceed the weight capacity for your specific chair/seating system configuration. Doing so could result in premature failure or injury.

## Q. TRANSIT USE

### WARNING

1. If possible and feasible, the rider should transfer to the Original Equipment Manufacturer vehicle seat and use the vehicle restraint.
2. If the wheelchair is used for transport, it must be used in a forward-facing seating position.
3. The rider must not weigh more than 165 lbs.
4. Figure 1 shows the location of the wheelchair securement points.
5. Use only with Wheelchair Tiedown and Occupant Restraint Systems (WTORS) that have been installed in accordance with the manufacturer's instructions and SAE J2249.
6. Attach WTORS to securement points in accordance with the manufacturer's instructions and SAE J2249.
7. Attach occupant restraints in accordance with the manufacturer's instructions and SAE J2249.

 **Q-NOTE**– To obtain a copy of SAE J2249 Wheelchair Tiedown and Occupant Restraint Systems for Use in Motor Vehicles, please contact: SAE International - 400 Commonwealth Drive - Warrendale, PA 15096 - 412.776.4970

If you fail to heed these warnings damage to your chair, a fall, tip-over or loss of control may occur and cause severe injury to the rider or others.

## R. TRANSIT OPTION

### ⚠ WARNING

1. Use only Wheelchair Tiedown and Occupant Restraint Systems (WTORS) which meet the requirements of SAE J2249 Recommended Practice - Wheelchair Tiedown and Occupant Restraint Systems For Use in Motor Vehicles. Do not use WTORS designed to rely on the wheelchair structure to transfer occupant restraint loads to the vehicle.
2. The wheelchair has been dynamically tested in a forward-facing mode for a 48-km/h frontal impact test. The wheelchair must be forward-facing during transport.
3. In order to reduce the potential of injury to vehicle occupants, wheelchair-mounted accessories, such as trays and respiratory equipment, should be removed and secured separately.
4. Postural supports and positioning devices should not be relied on for occupant restraint.
5. Do not alter or substitute wheelchair frame parts, components or seating.
6. Sudden stops or impacts can structurally damage your chair. Chairs involved in such incidents should be replaced.

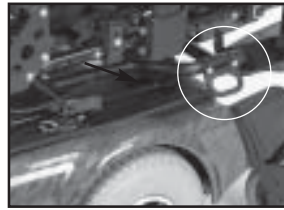

Front securement point

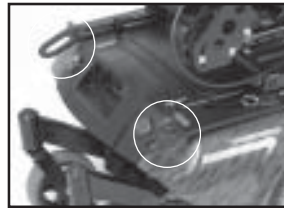

Rear securement point

## S. REAR WHEEL LOCKS

### ⚠ WARNING

**Rear wheel locks are NOT designed to slow or stop a moving wheelchair. Use the only to keep the rear wheels from rolling when your chair is at a complete stop.**

1. NEVER use rear wheel locks to try to slow or stop your chair when it is moving. Doing so may cause you to veer out of control.
2. To keep the rear wheels from rolling, always set both rear wheel locks when you transfer to or from your chair.
3. Low pressure in a rear tire may cause the wheel lock on that side to slip and may allow the wheel to turn when you do not expect it.
4. Make sure lock arms embed in tires at least 1/8 inch when locked. If you fail to do so, the locks may not work.

If you fail to heed these warnings damage to your chair, a fall, tip-over or loss of control may occur and cause severe injury to the rider or others.

## T. MODIFIED SEAT SYSTEMS

### ⚠ WARNING

**Use of a seat system not approved by Sunrise may alter the center of balance of this chair. This may cause the chair to tip over.**

1. Do not change the seat system of your chair UNLESS you consult your authorized supplier first.
2. Use of a seat system not approved by Sunrise may affect the folding mechanism of this chair.
3. Use of a seating system not provided by Sunrise is prohibited for transit use.

If you fail to heed these warnings damage to your chair, a fall, tip-over or loss of control may occur and cause severe injury to the rider or others.

## U. ANTI-TIP TUBES (optional) (Manual Carrier)

### ⚠ WARNING

Anti-tip tubes can help keep your chair from tipping over backward in most normal conditions.

1. Sunrise Recommends Use Of Anti-Tip Tubes:
  - a. UNLESS you are a skilled rider of this chair and are sure you are not at risk to tip over.
  - b. Each time you modify or adjust your chair. The change may make it easier to tip backward. Use anti-tip tubes until you adapt to the change, and are sure you are not at risk to tip over.
2. When locked in place (in the “down” position) anti-tip tubes should be BETWEEN 1 1/2 to 2 inches off the ground.
  - a. If set too HIGH, they may not prevent a tip-over.
  - b. If set too LOW, they may “hang up” on obstacles you can expect in normal use. If this occurs, you may fall or your chair may tip over.
3. Keep Anti-Tip Tubes Locked In Place UNLESS:
  - a. You have an attendant; or
  - b. You have to climb or descend a curb, or overcome an obstacle, and can safely do so without them. At these times, make sure anti-tip tubes are up, out of the way.

## VIII. SET-UP, ADJUSTMENT &amp; USE

**NOTES:****1. Work Surface For Set-Up:**

Use a flat surface, such as a table, to assemble, adjust and check your chair. This makes the steps easier and helps ensure a correct set-up.

**2. Fasteners:**

- Many of the screws and bolts on this chair are special high-strength fasteners and may have special coatings.
- Many nuts are of the Nylock type. They have a plastic insert to help prevent loosening.

**⚠ WARNING**

- 1. Use of improper fasteners may cause the chair to fail.**
  - 2. Over- or under-tightened fasteners may fail or cause damage to chair parts.**
  - 3. If bolts or screws become loose, tighten them as soon as you can. Loose bolts or screws can cause damage to other chair parts causing them to fail.**
- 3. Washers & Spacers:**
- Note the position of washers and spacers before disassembly.
  - To avoid damage to the frame, replace all washers and spacers when you reassemble parts.
- 4. Torque Settings:**
- A torque setting is the optimal tightening for a particular fastener. Use a torque wrench that measures 120 inch-pounds to secure screws, nuts and bolts on this chair.



**Q-NOTE**– Unless otherwise noted, use a torque setting of 120 inch-pounds for all fasteners.

**TOOLS YOU WILL NEED****1. Basic Tool Kit:**

To set-up, adjust and maintain your chair you will need the following tools:

- |                        |                           |                                 |
|------------------------|---------------------------|---------------------------------|
| • 3mm Allen Wrench     | • 13mm Socket Wrench      | • 7/16" box and open-end wrench |
| • 5mm Allen Wrench     | • 16mm Open-end Wrench    | • 1/2" box and open-end wrench  |
| • 6mm Allen Wrench     | • 19mm Open-end Wrench    | • 3/4" box and open-end wrench  |
| • 8mm Allen Wrench     | • Flat Head Screwdriver   | • 5/32" Allen wrench            |
| • 13mm Open-end Wrench | • Phillips screwdriver #2 | • Custom axle wrench            |
| • 17mm Socket Wrench   | • Standard Tools          |                                 |

You can obtain a multi-purpose tool kit from Sunrise, or buy the tools you need from a hardware store.

**2. Torque Wrench:**

If you plan to adjust and maintain this chair yourself, Sunrise recommends that you use a torque wrench.



**Q-NOTE**– The wrench must measure inch-pounds. You can buy a torque wrench and proper sockets from a hardware store.

## A. BATTERY REMOVAL (Figures 1, 2 & 3)

To remove the batteries for transporting or servicing:

### 1. Remove Batteries

- Remove seat following instructions in section "C. Power Base Seat Removal."
- Remove battery access panel by inserting a flat head screw driver between the panel and main shroud toward the back of the panel at the word "open".
- Push the screw driver forward until the panel lifts off.
- Unplug and remove batteries from rear of chair.
- Lift up batteries by lifting up on battery straps.

### 2. Battery Installation

See Section XI. Batteries, D for installation and wiring diagram.

#### **⚠ WARNING**

Batteries may weigh up to 55 lbs. Care must be taken to avoid injury when lifting up on battery straps.

## B. POWER BASE SEAT HEIGHT ADJUSTMENT

(Figure 4—Mount for power tilt shown)

- Remove pins (A) from all four seat mount posts.
- Select the desired seat height (rear seat mount should never be more than one position lower than the front).
- Reinsert the pins.

#### **⚠ WARNING**

Ensure both front seat posts are positioned to the same height. Rear seat posts should also be set to the same height.

## C. POWER BASE SEAT REMOVAL (Seat Frame)

### 1. Remove Seat

(Figures 5 & 6)

- Remove safety lock-out pin (B).
- Pull the two seat release levers upward
- Tilt seat backward slightly
- Pull the forward seat and remove.
- When replacing the seat into the mounts, ensure you do not pinch your fingers.

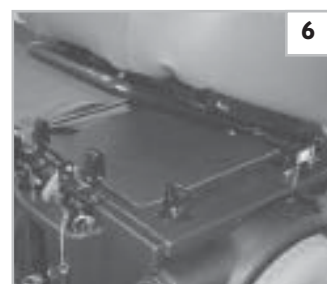
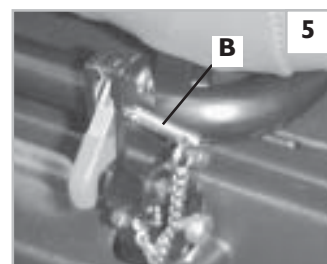
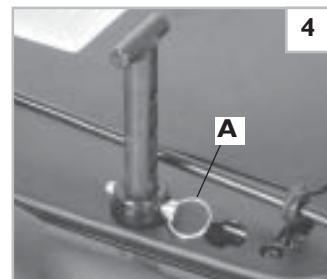
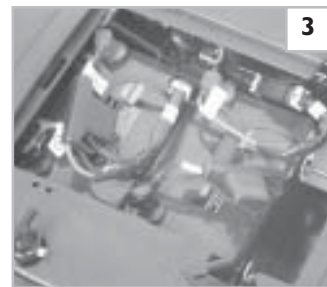

## D. POWER BASE SHROUD REMOVAL

The plastic protective shroud can be removed for adjustment or servicing.

### 1. Remove Colored Shroud

Two removable colored shroud covers are Velcro®-ed on to the sides of the main shroud. To remove, simply peel the colored shroud off of the main shroud as shown in Figure 7.

### 2. Remove Main Shroud

- a. Remove both brake releases by unscrewing the front connection and pulling them out. (Figure 8)
- b. Lift the middle shroud assembly off.

### 3. Replace Main Shroud

Replace shroud by reversing above instructions.

## E. CHECK-OUT

Once the wheelchair is assembled and adjusted, it should roll smoothly and easily. All accessories should also perform smoothly.

After the wheelchair has been set up be sure the chair performs to your specified operational settings (see Operating Guide). If the chair does not perform to specifications, turn the wheelchair OFF immediately and reprogram operational specifications using the Quickie Hand Held Programmer.

**Repeat this procedure until the wheelchair performs to specifications before attempting active use of the wheelchair.**

If you have any problems, follow these procedures:

1. Review the Set-up, Adjustment & Use section and Operating Guide to make sure chair was properly prepared.
2. If your problem persists, contact your authorized supplier. If you still have a problem after contacting your authorized supplier, contact Sunrise customer service. See the introduction page for details on how to contact your authorized supplier or Sunrise customer service.

### **⚠ WARNING**

**When properly set up, this chair will operate smoothly. Check to see that all components work properly. If you detect a problem, be sure to correct it before use.**

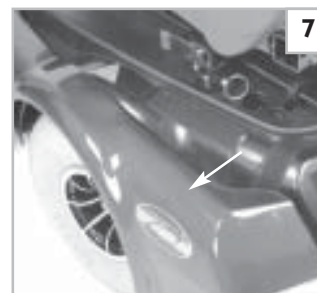

## F. BACKREST

### I. To Secure The Backrest For Operation:

- Lift backrest to upright position.
- When secured, backrest pin will lock into place.

 **Q-NOTE**– Zippie series wheelchairs are shipped with the backrest in a folded position.

## G. SWING-AWAY HANGERS (60°, 70°, or 90°)

(Fig. 9)

### I. Attaching/Removal

- Place swing-away pivot saddle (A) into the receiver on front frame tube with the footrest facing outward from the frame.
- Rotate the footrest inward until it locks into place on locking bolt.
- To remove hanger, push release latch (B) toward the frame, rotate footrest outward, and lift.

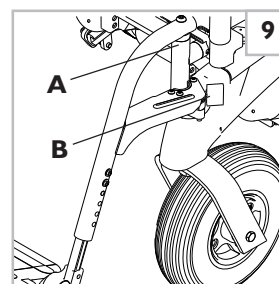

**Swing-Away Hanger**

## H. ARTICULATING LEGREST (Optional)

(Fig. 10)

### I. Attaching/Removal

- Place swing-away pivot saddle (A) into the receiver on front frame tube with the footrest facing outward from the frame.
- Rotate the footrest inward until it locks into place on locking bolt.
- To remove hanger, push release latch (B) toward the frame, rotate footrest outward, and lift.

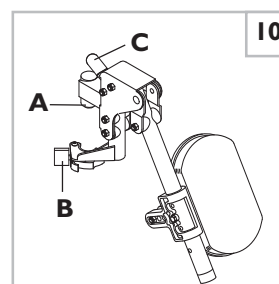

**Articulating Legrest**

### 2. Elevating

- To raise legrest, lift to desired position. Legrest will automatically lock in place.
- To lower legrest, while seated in chair hold lever (C) down, lower legrest to desired position, then release lever. Legrest will automatically lock in place.

## I. ELEVATING AND 90° ELEVATING LEGRESTS (Optional)

(Fig. 11)

### I. Attaching/Removal

- Place swing-away pivot saddle (A) into the receiver on front frame tube with the footrest facing outward from the frame.
- Rotate the footrest inward until it locks into place on locking bolt.
- To remove hanger, push release latch (B) toward the frame, rotate footrest outward, and lift.

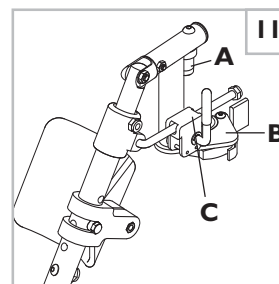

**90° Elevating Legrest**

### 2. Elevating

- To raise legrest, lift to desired position. Legrest will automatically lock in place.
- To lower legrest, while seated in chair hold lever (C) down, lower legrest to desired position, then release lever. Legrest will automatically lock in place.

**J. COMPOSITE FOOTPLATE (Fig. 12)**

**1. Height Adjustment**

- a) Remove retaining bolts in the frame tube (A).
- b) Slide footplate and extension tubes to desired height.
- c) Left and right footrest will normally be at equal height.
- d) Replace and tighten bolts.

**K. KIDS & ADULT ANGLE ADJUSTABLE FOOTPLATE**

(Figs. 13 & 14)

**1. Height Adjustment (Fig. 13)**

- a) Remove the retaining bolt from the frame tube (A).
- b) Move footplate assembly to desired height.
- c) Left and right footrest will normally be at equal height.
- d) Replace and tighten bolt.

**2. Angle Adjustment (Fig. 14)**

- a) Loosen fasteners (B) until the adjustable clamp and footplate rotate freely on the mounting tube.
- b) Adjust the angle of the footplate.
- c) Tighten nuts.

**3. Position Adjustment (Fig. 14)**

- a) Remove footplate fasteners (B).
- b) Move footplate to the desired location.
- c) Replace and tighten fasteners.

**L. ALUMINUM FOOTPLATE (Fig. 15)**

**1. Height Adjustment**

- a) Remove set screws (A) from frame tube.
- b) Slide footplate to desired height.
- c) The adjustment on each side of the footrest will normally be of equal height.
- d) Replace and tighten set screws.

**M. 90° FOOTBOARD (Fig. 16)**

**1. Height Adjustment**

- a) Loosen the nuts on the footplate clamp assembly (A).
- b) Slide footplate clamps to desired height.
- c) Tighten nuts.

**2. Angle Adjustment**

- a) Loosen nuts under the footplate assembly (B) until the adjustable clamp rotates freely on the supporting tube.
- b) Adjust the angle of the footplate.
- c) Slide it forward or back for correct placement.
- d) Tighten nuts.

**3. Removing Footboard**

- a) Unscrew the lock knobs (C) and lift out of clamp assembly.

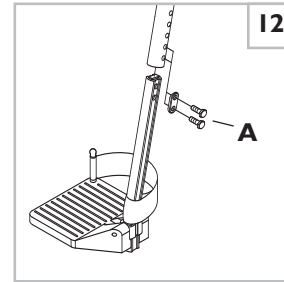

**Composite Footplate**

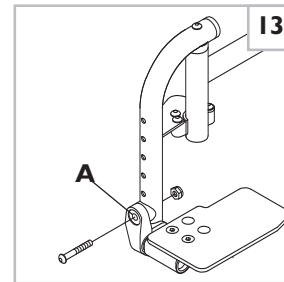

**Angle Adjustable Footplate**

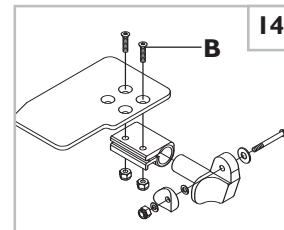

**Footplate Angle & Position Adjustment**

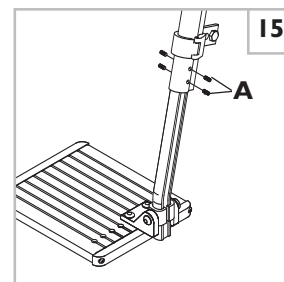

**Aluminum Footplate**

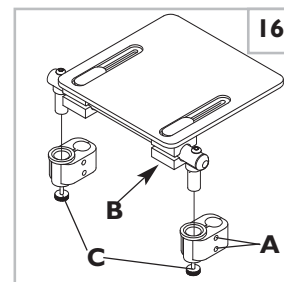

**90° Footboard**

## N. PLATFORM FLIP-UP FOOTPLATE (Fig. 17)

### 1. Height Adjustment

- Remove retaining bolts in the frame tube (A).
- Slide footplate and extension tubes to desired height.
- The adjustment on each side of the footrest should be of equal height.
- Replace and tighten bolts.

### 2. Angle Adjustment

- Loosen the nuts under the footplate clamp (B) until the adjustable clamp and footplate rotate freely on the mounting tube.
- Adjust the angle of the footplate.
- Tighten nuts.

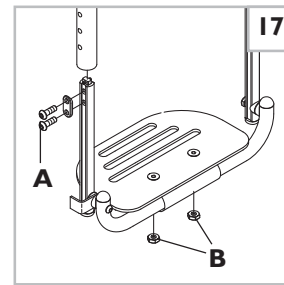

**Platform Flip-up Footplate**

## O. HEIGHT-ADJUSTABLE ARMRESTS (Optional) (Fig. 18)

### 1. Installation

- Slide the outer armpost into the receiver mounted to the wheelchair frame.
- The armrest should lock in place automatically.

### 2. Removing Armrest

- Press release lever (A) and remove the armrest.

 **Q-NOTE**– Release lever should move freely. Do not force or over rotate.

### 3. Height Adjustment

- Rotate release lever (A) to second stop.

 **Q-NOTE**– Release lever should move freely. Do not force.

- Slide armrest pad up or down.
- Return lever to locked position against armpost.
- Push arm pad until upper armpost locks firmly into place.
- A snap lock is engaged if the armrest is raised to its highest adjustment. To disconnect the snap lock, press in on the button head and press the armrest down.

### 4. Replacing Armrest

- Slide armrest back into receiver until it stops.

 **Q-NOTE**– Check to make sure release lever is engaged by pulling up on armrest.

### 5. Adjusting Armrest Receiver Fit

To tighten or loosen the fit of the outer armpost in the receiver:

- Loosen the four bolts on the side of the receiver.
- With the armrest in the receiver, squeeze the receiver to achieve the desired fit.
- Tighten the four bolts.

### 6. Adjusting Inner Armpost Fit

- Two set screws (C) are installed in the outer armpost.
- Turn the set screws in or out until the desired fit is achieved.

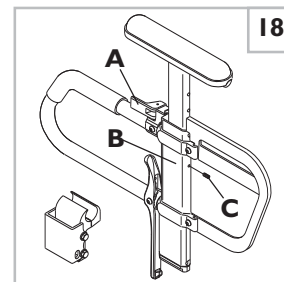

**Height Adjustable Armrest**

## P. JOYSTICK & ENHANCED DISPLAY (Figs 19, 20, 21, 22)



### 1. To Connect (Fig. 21)

- Line up the groove on the joystick cable (A) with the groove on the wing of the wheelchair cable (B).
- Push the connectors together and then turn the wing of the wheelchair cable until the two wings line up (C).

### 2. To Disconnect (Fig. 22)

- Turn the wing (D) so that both the groove on the wing of the wheelchair cable and the groove on the joystick cable line up.
- Pull apart the two connectors.



**Qr3 Remote Joystick**



**Enhanced Display**

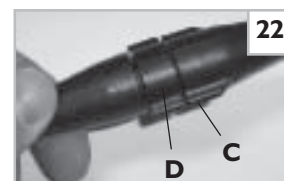
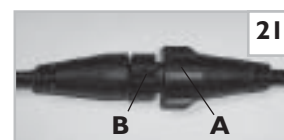

**Q. TO ADJUST THE HEIGHT OF THE JOYSTICK OR ENHANCED DISPLAY (Fig. 23)**

1. Loosen the two Socket Head screws (E).
2. Slide the clamp (F) up or down until in desired position.
3. Retighten the two Socket Head Screws (E).

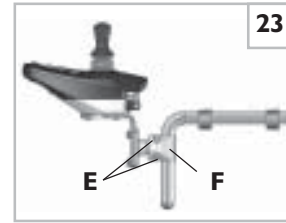

**R. JOYSTICK OR ENHANCED DISPLAY SWING-AWAY RETRACTABLE MOUNT (Optional) (Fig. 24)**

The joystick or Enhanced Display is mounted with a mechanism which allows the control to be locked in a forward or retracted position using magnets.

**Adjustment**

- a. To retract the joystick or Enhanced Display, push outward on the inside of joystick.
- b. Push the joystick or Enhanced Display away from front of armrest until it locks into retracted position.
- c. To return to forward position, push the joystick or Enhanced Display forward until it locks into place.

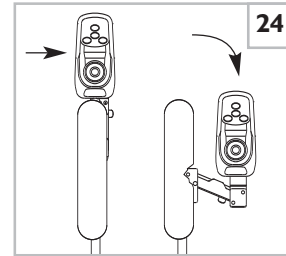

**S. WHEEL LOCKS**

Zippie wheelchairs are shipped with wheel locks. Wheel locks are installed at Sunrise unless you have requested otherwise.

Use a torque setting of 100 in./lbs when setting-up wheel locks.

**1. Wheel Lock**

- a. Loosen the screws on the top of each clamp. Do not attempt to remove one screw at a time.
- b. Slide assembly toward drive wheel until clamp embeds into tire to prevent wheel movement when in locked position.
- c. Adjust angle position.
- d. Tighten screws.

**T. ANTI-TIP TUBES - REAR (Manual carrier) (Fig. 25)**

**1. To Insert Anti-Tip Tubes into Receivers**

- a) Press the anti-tip release button on the anti-tip tube so that the release pin is drawn inside.
- b) Insert the tube into the anti-tip receiver.
- c) Turn the anti-tip tube until release pin is positively engaged in the receiver mounting hole.
- d) Insert second anti-tip tube the same way.

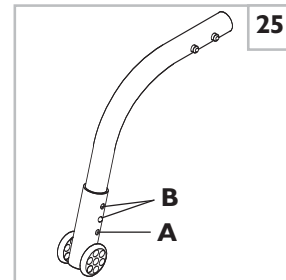

**Anti-Tip Height**

**2. To Adjust Anti-Tip Height**

- a) Press the anti-tip wheel release button (A) so the release pin is drawn inside.
- b) Raise or lower to one of the three pre-drilled holes.
- c) Turn the anti-tip tube until release pin is positively engaged in the receiving hole (B).
- d) Adjust the second anti-tip tube wheel the same way. Both wheels should be exactly the same height.

**U. SEAT REMOVAL (Figs. 26 & 27)**

1. Disconnect joystick.
2. Pull out the safety pin from the left front seat post (Fig. 26).
3. Lift up on both front seat latches (Fig. 27).
4. Tilt the seat back, slide it forward, and remove from the base.



## V. MANUAL CARRIER (optional) (Figures 28 & 29)

The manual carrier is an optional accessory that can be used in place of the power base. The Z-Bop seating system can be removed and placed on the manual carrier. The attendant would be required to push the chair's occupant once fitted with the seating system. Once the seating system is placed on the Manual Carrier, adjustment can be made to ensure the seat does not freely move while locked into the manual carrier. This can be done by adjusting the jam nut (A).

## W. CHECK-OUT

After the wheelchair is assembled and adjusted, it should roll smoothly and easily. All accessories should also perform smoothly. If you have any problems, follow these procedures:

- a) Review assembly and adjustment sections to make sure chair was properly prepared.
- b) Review troubleshooting guide.
- c) If your problem persists, contact your authorized Sunrise supplier. If you still have a problem after contacting your authorized Sunrise supplier, contact Sunrise customer service. See the introduction page for details on how to contact your authorized Sunrise supplier or Sunrise customer service.

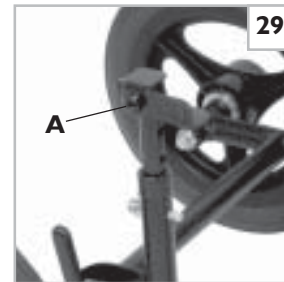

## IX. POWER BASE OPERATING GUIDE

## A. CIRCUIT BREAKERS

## 1. Notes:

Your Zippie Z-Bop has a circuit breaker protruding through the shroud cover at the right rear of the chair.

- In the unlikely event of a short circuit or heavy overload, all power to your chair will be shut off.
- To reset your chair, depress the circuit breaker button located at the rear corner of the chair. A few minutes wait is required before the circuit breaker will reset.

## 2. Repeated Shutdown:

If the chair continues to shut down after resetting, have it serviced by a supplier.

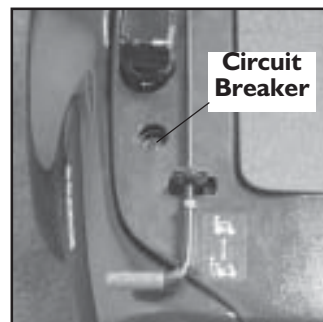

## B. MOTOR LOCKS

Disconnect the motor locks when you need to manually push the chair. (For example, in an emergency, or if batteries fail).

**⚠ WARNING**

1. Do not disengage motor locks unless power to the chair is off.
2. With either one or both brakes released, the chair will not operate and the battery charge indicator will flash 9 bars rapidly (if power to the chair is on.)
3. Be aware that the chair will not have brakes in the free-wheel position.
4. Make sure that the person pushing the chair has full control when motor locks are disengaged.

## 1. Release Motor Locks

- a. At the back of the chair you will find two levers marked in red.
- b. Pull the brake releases backward.

## 2. Engage Motor Locks

- a. At the back of the chair you will find two levers marked in red.
- b. Push the brake releases forward. (A).

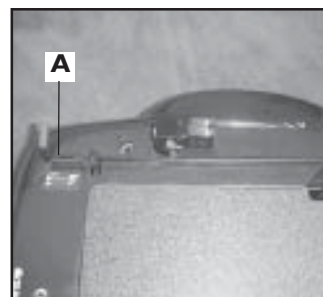

## C. PERFORMANCE CONTROL SETTINGS

**Q-NOTE**— Seek advice regarding checking and adjusting settings.

1. It is vital to match control settings to your level of function and ability.
2. Consult your health care professional and your supplier to select the best control settings for you.
3. Check and adjust the settings every six to twelve months.

**⚠ WARNING**

**Adjust the control settings immediately if you notice any change in your ability to:**

- Control the joystick.
  - Avoid running into objects.
4. Control Settings can be adjusted by your dealer.

## D. QUICKIE HAND HELD PROGRAMMER OR QUICKIE PC SETUP STATION (Optional)

**⚠ WARNING**

**Program settings beyond the ability of the user can result in serious injury. Consult your health care advisor before you alter settings.**

The Quickie Hand Held Programmer or Quickie PC Set-Up Station lets you adjust the control settings of the Rhythm. Listed below are a few of the many settings that can be adjust via the Quickie Hand Held Programmer or Quickie PC Setup Station. (See Quickie Owners Manual for full programmable parameters.)

- acceleration rate
- deceleration rate
- turn acceleration
- turn deceleration
- forward speed (max & min)
- reverse speed (max & min)
- turn speed (max & min)
- steer correct

#### Programming the Chair:

- Insert Quickie Hand Held Programmer or Quickie PC Setup Station plug into the Programmer socket on the front of the joystick.
- Program as needed.
- Remove plug.

 **Q-NOTE**– Review the *Quickie Hand Held Programmer or Quickie PC Setup Station Owner's Manual* for more details on how to program your chair.

## E. THERMAL ROLL-BACK

Your chair has a thermal roll back circuit. This protects the controller from damage due to overheating. In extreme conditions (such as repetitive hill climbing) the circuit will decrease the power to your motors. This allows the chair to operate at a reduced speed. When the controller cools, the chair will return to normal speed.

## F. CIRCUIT BREAKERS

Your Quickie Rhythm has a single circuit breaker.

- In the unlikely event of a short circuit or heavy overload, all power to your chair will be shut off.
- To reset your chair, depress the circuit breaker button. A few minutes wait is required before the circuit breaker will reset.

#### Repeated Shutdown:

If the chair continues to shut down after resetting, have it serviced by a supplier.

## G. JOYSTICK ASSEMBLY

The joystick connects to a controller, which controls the chair's performance. The joystick assembly consists of the following parts:

 **Q-NOTE**– Review the *Quickie QR Owner's Manual* for more details on the functions of your joystick.

#### 1. On/Off Button (V)

The On/Off Button allows you to turn your wheelchair on and off. When you press the On/Off Button the lights on the joystick will illuminate and the chair's power will be turned on. Press the button again and the chair's power will be turned off.

#### 2. Speed Control Knob (D) (QR Option)

Use the speed control knob to adjust the maximum speed of your chair. Turn it counter-clockwise to reduce speed; turn it clockwise to increase speed.

#### 3. Battery Charge Indicator (B) (standard)

- Green lights indicate that batteries are fully charged.
- Amber lights indicate that batteries need recharging.
- When the lights stay in the red band, the batteries must be recharged.

#### 5. On/Off Mode switch (A) (option)

The on/off mode switch is located on the rear face of the joystick housing. It is a toggle switch. Turning the chair on or off, is accomplished by pressing the switch downward. The switch will automatically return to the center point. Alternate locations exist for this switch. Please see your supplier in the event that you wish to relocate or re-orient this switch.



**QR3 Remote Joystick**

**6. Mode Button (J) and Mode Switch (option)**

The mode button and mode switch allow you to select from 4 (four) different programmable drive profiles or actuator mode sets.

- Push up the on/off mode select toggle switch to index among the four drive and actuator modes. The selected mode indicator will flash.
- Push joystick either left, right, forward or reverse to select one of the four drive profiles. To select the actuator modes, push up on the mode select switch twice.
- The drive profiles are indicated by the mode indicators (G) and the actuators are indicated by the four actuator lights (H).
- To exit drive mode, simply push the joystick to begin driving.
- To exit actuator mode, simply push the on/off mode toggle up one or more times until the indicator no longer flashes.

**7. Joystick (E)**

The joystick controls the direction and speed of your chair. Turn the chair on and move the joystick in the direction you want to go.

- Moving the joystick from the neutral (center) position disengages the brakes, allowing the chair to move.
- The chair will move faster the more you move the joystick away from neutral.

 **Q-NOTE**– If your speed becomes hard to manage, release the Joystick and the chair will come to a complete stop.

- When you release the joystick it will return to neutral; the chair will slow to a stop and the brakes will reengage.
- We recommend that you switch the chair off if you stop for any length of time. This will conserve battery power.

 **Q-NOTE**– Once the chair stops, switching the chair off will not affect the brakes.

**9. Joystick Boot (F)**

Make sure the boot is not torn or cracked (this could allow debris, water or moisture to enter). If the boot is torn or cracked, replace it as soon as you can.

**10. Remote Switch Jacks (option– not shown)**

Two 1/8" switch jacks are optional to provide remote switch control of the on/off power function and the mode select function. Any of the single switches offered by Sunrise Medical can be used to connect to either or both of these jacks (except the single zero touch switch).

**⚠ WARNING**

1. Never use the ON/OFF switch to stop your chair except in an emergency. This will result in an abrupt stop, and may cause you to fall.
2. To slow or stop your chair, return the joystick to neutral.

**H. ENHANCED DISPLAY**

Please refer to the Quickie Enhanced Display owner’s manual.

**I. MOTOR LOCKS**

Disconnect the motor locks when you need to manually push the chair. (For example, in an emergency, or if batteries fail).

**⚠ WARNING**

1. Do not disengage motor locks unless power to the chair is off.
2. Be aware that the chair will not have brakes in the free-wheel position.
3. Make sure that the person pushing the chair has full control when motor locks are disengaged.

**1. To Disengage Motor Locks:**

Pull the lever out and away from the wheel to disengage the motor lock.

**2. To Engage Motor Locks:**

Push the lever in to return to the drive position.

 **Q-NOTE**– If the lever is difficult to disengage, rock the wheelchair slightly from front to rear and/or push against the chair while moving the lever.

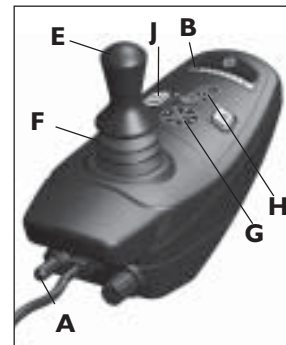

**QR3 Remote Joystick**



**Enhanced Display**

## X. BATTERIES

### A. INTRODUCTION

#### 1. Notes:

- Batteries supply the power for your chair. They contain a finite amount of energy and have limits on how long they can store and supply energy.
- You can charge batteries only a certain number of times before they will fail and no longer hold a charge.
- For answers to questions about batteries, consult your supplier.

#### 2. Use Proper Batteries:

Your chair operates on two 12 volt batteries.

- They should be 40 AMP or U1 for the Zippie Z-Bop. Only deep cycle sealed case construction batteries should be used in this device.
- When you buy a replacement, insist on a deep cycle sealed case. Do not use a car starter battery.

#### 3. Breaking In:

- A battery requires “breaking-in” for the first 6 to 12 charges. It will not accept a full charge for this period.
- It is best to limit the length of your trips until you break the batteries in and you know the range of your chair.

#### 4. Discharged Batteries:

- **Never** allow a battery to completely discharge. If you operate your wheelchair until it has almost stopped, you will greatly reduce the life of your batteries.
- **Never** let a battery sit in a discharged condition. Give unused or stored batteries a full charge once per month.
- **Always** fully charge the batteries. Avoid “topping off” with frequent charges.

### ⚠ WARNING

Never connect a life support or auxiliary device to a wheelchair battery. The electrical system may fail and result in severe injury to or death of rider.

### B. BATTERY CHARGER

A battery charger produces a direct current (DC). When applied to a discharged battery, this reverses the chemical reaction that led to its discharge.

#### 1. Charge Rate. How fast a battery will charge depends on:

- Its electrical capacity, state of charge, electrolyte temperature, and internal condition.
- The DC output of the charger. (The charge rate will vary if the alternating current (AC) supply is higher or lower than 110 volts).

#### 2. CAUTION– To Avoid Damage to the Charger

- **Never** expose charger to rain or snow.
- **Never** unplug charger by pulling on the electrical cord. This will damage the cord.
- **Never** open a charger or attempt to repair it yourself. Return charger to Sunrise or have repairs made only by a qualified person.
- Keep cord out of the way, where it will not be stepped on, tripped over, or damaged.

#### 3. CAUTION– To Avoid Damage to the Battery

- Make sure you use the correct setting for sealed (gel) batteries (located on the off-board charger).

- **Never** charge a frozen battery. A fully charged battery will rarely freeze, but the fluid in a discharged battery can freeze at 16 degrees Fahrenheit (minus 9 degrees Centigrade). If you suspect a battery is frozen, thaw it before charging.

### ⚠ WARNING

Lead acid batteries generate explosive gas while charging. Completely read and follow all warnings about the batteries in this user instruction manual and any labels applied to the product. Failure to do so could result in fire, explosion, injury and/or death.

### C. ACID BURNS (UNSEALED WET CELL BATTERIES)

Acid in batteries is corrosive. If you choose to use wet cell batteries, they can cause serious burns to the eyes and skin and can damage floors, furniture, clothing and your wheelchair.

### ⚠ WARNING

1. Use extreme care not to spill acid when you handle wet cell batteries. Keep batteries upright.
2. Avoid contact of acid with bare skin or clothing.
3. Always wear rubber gloves and safety glasses when you handle batteries.
4. If acid contacts your skin or clothing, wash immediately with soap and water.
5. If acid contacts your eyes, immediately flood eyes with cold running water for at least 15 minutes. Seek medical attention immediately.

Sunrise Medical does not recommend the use of wet cell batteries on this chair.

### D. CONNECTING BATTERIES IN BATTERY WELL

#### ⚠ WARNING

1. Each battery can weigh up to 45 lbs. Take care to avoid injury when lifting.
2. Keep batteries upright. Take care not to spill acid (wet cell batteries).
3. Always wear rubber gloves and safety glasses when you handle batteries.
4. Before working around batteries, remove all metal personal effects, such as necklaces, rings, watches, pins, and other metal jewelry that might contact battery terminal and cause a short.
  1. Attach battery harness to battery post. Connect red to positive terminal and black to negative terminal.
  2. Tighten all terminal fasteners using two wrenches.
  3. Cover battery posts with insulating caps on harness.
  4. Lift batteries into battery well.

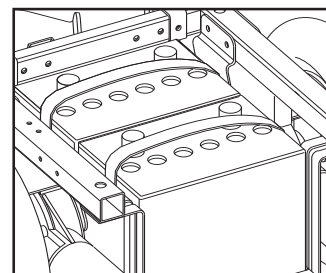

Refer to wiring diagram for battery connections

**⚠ WARNING**

Batteries weigh up to 45 pounds. Lifting batteries may cause back strain. If you fail to heed these warnings severe injury may occur to you.

5. Plug battery harnesses into chair harness.
6. Place battery access panel, trunk insert and deck lid into position.

**⚠ WARNING**

Never make direct contact across both battery terminals, as an explosion may occur. A spark may result in an explosion and/or fire resulting in severe injury or death.

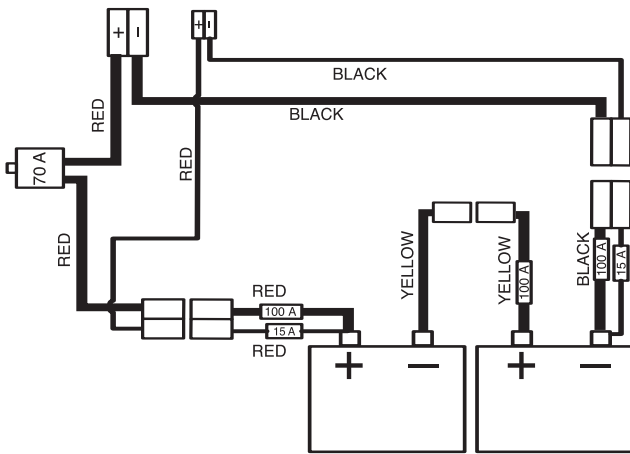

**E. CHARGING BATTERIES**

**⚠ WARNING**

To avoid the risk of severe injury or death from electrical shock, fire or explosion while charging:

**⊘ PROHIBITED!**

1. **Never** connect charger to a 240 volt source. The main input voltage is 110 volts.

**⊘ PROHIBITED!**

2. **Never** touch the charger after it is connected to an electrical outlet. This may cause electrical shock.

**⊘ PROHIBITED!**

- **Never** connect or disconnect charger from battery while there is power to the charger.

**⊘ PROHIBITED!**

3. **Never** use an extension cord. Use of an improper cord could damage the charger or cause a fire or electrical shock.
4. A battery emits explosive hydrogen gas during charging. To reduce the risk of fire or explosion:
  - Make sure area is well vented. Never charge battery in a closed-in area.
  - Never smoke or allow a spark, flame or high heat near battery during charging.
  - Never allow metal tools or chair parts to make direct contact across both battery terminals.
5. **Never** look directly into cells when charging battery (wet cell batteries).

**ALWAYS:**

1. Use the charger that comes with your wheelchair. Read and follow all instructions and warnings.
2. Make sure room is well ventilated.
3. Turn off all power to your chair.
4. Connect and disconnect battery cables with caution.
5. Make sure to allow enough time to fully charge batteries.



**Q-NOTE-** Batteries should never be left for long periods in the discharged state. Unused or stored batteries should be given a charge once per month.

6. Charge batteries by plugging in the battery charger cord into the chair and an outlet.
7. Or, use the off-board charger by plugging the offboard charger cord into the chair.

**F. DISPOSING OF BATTERIES**

**⚠ WARNING**

1. All batteries once they have reached the end of their useful life are deemed to be hazardous waste.
2. For further information on handling and recycling contact your local recycling authority.
3. Always dispose of product through a recognized agent.

## XI. MAINTENANCE

### A. NOTES

1. Proper maintenance will improve performance and extend the useful life of your chair.
2. Clean your chair regularly. This will help you find loose or worn parts and will make your chair easier to use.
3. To protect your investment, have all major service and repair work done by your supplier.

#### **⚠ WARNING**

1. **Your chair needs regular maintenance for peak performance and to avoid injury from chair failure, damage or premature wear.**
2. **Inspect and maintain this chair strictly per the "Maintenance Chart".**
3. **If you detect a problem, make sure to service or repair the chair before use.**
4. **At least once a year, have a complete safety check and service of your chair performed by a supplier.**

### B. CLEANING

#### 1. Plastic Shroud Cover:

- Clean the plastic finish with mild soapy water monthly.

#### 2. Motors:

- Clean around motor area weekly with a slightly damp (not wet) cloth.
- Wipe off or blow away any fluff, dust, or dirt on or around the motors.
- Note: You do not need to grease or oil the chair.

#### 3. Upholstery:

- Hand-wash only as needed. Machine washing may damage fabric (rehab seat only).
- Drip-dry only. Heat from a dryer may damage fabric.

 **Q-NOTE**– Washing the fabric may decrease fire retardant properties.

### C. STORAGE TIPS

1. Store your chair in a clean, dry area. If you fail to do so, parts may rust or corrode.
2. Before using your chair, make sure it is in proper working order. Inspect and service all items on the "Maintenance Chart".
3. If you store this chair for more than three months, have it inspected by a supplier before use.

### D. BATTERY MAINTENANCE

#### **⚠ WARNING**

1. **To prevent an acid spill, always keep batteries upright. (wet cell batteries)**
2. **Never smoke or hold an open flame near batteries.**
3. **Always wear rubber gloves and safety glasses when you handle batteries.**

#### 1. Maintenance Schedule:

This varies for different types of batteries. Always follow the instructions supplied with your batteries.

 **Q-NOTE**– Always wear rubber gloves and safety glasses when you handle or service batteries.

#### 2. Adding Water: (Wet Cells Only)

- Wet-type lead acid batteries need periodic replacement of water lost.

 **Q-NOTE**– Use distilled water only.

- Check the battery fluid level about once a week. When you remove the stoppers (on top of the battery) there should be one-eighth to one-quarter of an inch of fluid above the internal plates. Do not overfill.

#### 3. Corrosion:

Check battery terminals often for corrosion.

- a. If corrosion is present, use a wire brush to clean the terminals.

 **Q-NOTE**– Always wear safety glasses and rubber gloves.

- b. Use baking soda to neutralize acid.
- c. Use petroleum jelly to re-grease the terminals after connecting cables to battery. (Completely cover the terminal nut and bolt, cable clip and any exposed cable with jelly).

#### 4. For Answers To Questions: Contact your supplier.

### E. PNEUMATIC TIRES

#### **⚠ WARNING**

1. **Do not use this chair if any of the tires are under-inflated or over-inflated.**
2. **Low pressure in a tire may cause the chair to veer to one side and result in loss of control.**
3. **An over-inflated tire may burst.**
4. **Never use a gas station pump to inflate a tire. Such pumps provide air at high volume, and may cause tire to burst.**
  1. Check for signs of wear and correct air pressure in pneumatic tires weekly.
  2. For best performance, inflate tires to the same pressure level, as shown on the tire sidewall:
    - 10" pneumatic drive wheels - 30 to 40 psi
  3. **CAUTION:**  
To prevent tire damage:
    - Use a hand pump (or a low volume air pump) to inflate tires.
    - Use a tire gauge to check pressure.



### F. TO REPAIR OR REPLACE A TIRE

#### **⚠ WARNING**

Residual air pressure in tires can cause severe injury. Make sure you release all air in tire before attempting to service or repair tires.

#### 10" Drive Wheels:

- a. Elevate and securely support chair so that wheel is off the ground. Release all air from tire (solid aluminum rim only).
- b. Bend locking tab away from nut.
- c. Remove lock nut.
- d. Remove washer.
- e. Remove wheel from chair.
- f. Make sure all air has been removed from tube.
- g. Remove all bolts holding two halves of rim together (not

applicable on solid aluminum rim), and remove tire and solid insert.

h. Repair or replace inner tube (replace rim strip if necessary).

 **Q-NOTE**– Do not use pneumatic inner tube in tires with two-piece rims.

- i. Reassemble the wheel. Use a torque setting of 420 in.-lbs. to re-tighten bolts.
- j. Install wheel on chair by replacing center lock washer, nut and plastic dome. Use a torque setting of 180 in.-lbs. to retighten bolts.
- k. Inflate tire to proper pressure level (listed on tire sidewall).

### G. MOTOR BRUSHES

Check the motor brushes every four (4) months for wear. The brushes should be clean and shiny. Replace worn or blackened brushes.

### H. ORDERING PARTS

When you order parts, provide the following:

1. Model of chair
2. Serial number of chair
3. Left hand or right hand control
4. Part number, description and quantity of parts you need.
5. State reason for replacement.

### I. MAINTENANCE CHART

You should check the items on this chart at the indicated intervals. If any of the items are loose, worn, bent or distorted, immediately have them checked and/or repaired by your authorized Sunrise supplier. Frequent maintenance and servicing will improve performance and extend wheelchair life, and help prevent injuries.

CHECK...	Daily	Weekly	Monthly	Quarterly	Annually
Charge batteries	✓				
Check tires for proper inflation level		✓			
Check batteries for proper electrolyte level (wet cell only)		✓			
Check plugs and connectors for proper connections			✓		
Check all moving parts for wear				✓	
Inspect all nuts, bolts and fasteners for looseness or wear				✓	
Inspect upholstery for wear				✓	
Remove and inspect motor brushes				✓	
Service by authorized supplier					✓

### J. TOOLS YOU WILL NEED

#### 1. Basic Tool Kit:

To set-up, adjust and maintain your chair you will need the following tools:

- 3mm Allen Wrench
- 5mm Allen Wrench
- 6mm Allen Wrench
- 8mm Allen Wrench
- 13mm Open-end Wrench
- 17mm Socket Wrench
- 13mm Socket Wrench
- 16mm Open-end Wrench
- 19mm Open-end Wrench
- Flat Head Screwdriver
- Phillips screwdriver #2
- Standard Tools
- 7/16" box & open-end wrench
- 1/2" box and open-end wrench
- 3/4" box and open-end wrench
- 5/32" Allen wrench
- Custom axle wrench
- Tire Pressure Gauge

You can obtain a multi-purpose tool kit from Sunrise, or buy the tools you need from a hardware store.

#### 2. Torque Wrench:

If you plan to adjust and maintain this chair yourself, Sunrise recommends that you use a torque wrench.

 **Q-NOTE**– The wrench must measure inch-pounds. You can buy a torque wrench and proper sockets from a hardware store.

**XII. SUNRISE LIMITED WARRANTY****ZIPPIE Z-BOP****A. FOR FIVE (5) YEARS**

Sunrise warrants the frame of this wheelchair against defects in materials and workmanship for five years from date of first consumer purchase.

**B. FOR ONE (1) YEAR**

We warrant all Sunrise-made parts and components of this wheelchair against defects in materials and workmanship for one year from the date of first consumer purchase.

**C. FOR ONE (1) YEAR**

We warrant all motors, gearboxes, batteries, and electronic components of this wheelchair against defects for one year from the date of first consumer purchase.

**D. LIMITATIONS**

1. We do not warrant:
  - a. Tires and tubes, upholstery, pads and push-handle grips.
  - b. Damage from neglect, accident, misuse, or from improper installation or repair.
  - c. \Products modified without Sunrise Medicals express written consent.
  - d. Damage from exceeding the weight limit.
2. This warranty is VOID if the original chair serial number tag is removed or altered.
3. This warranty applies in the USA only. Check with your supplier to find out if international warranties apply.
4. This warranty is not transferable and only applies to the first consumer purchase of this wheelchair through an authorized Sunrise Medical dealer.

**E. WHAT WE WILL DO**

Our sole liability is to repair or replace covered parts. This is the exclusive remedy for consequential damages.

**F. WHAT YOU MUST DO**

1. Obtain from us, while this warranty is in effect, prior approval for return or repair of covered parts.
2. Return the wheelchair or part(s), freight pre-paid, to Sunrise Mobility Products Division at: 2842 Business Park Avenue, Fresno, CA 93727-1328.
3. Pay the cost of labor to repair, remove or install parts.

**G. NOTICE TO CONSUMER**

1. If allowed by law, this warranty is in place of any other warranty (written or oral, express or implied, including a warranty of merchantability, or fitness for a particular purpose).
2. This warranty gives you certain legal rights. You may also have other rights that vary from state to state.

Record your serial number here for future reference:

---