

ZIPPIE

Zippie® IRIS

- WITH TRANSIT OPTION
- WITHOUT TRANSIT OPTION

Supplier:

This manual must be given to the rider of this wheelchair.

Rider:

Before using this wheelchair read this entire manual and save for future reference.

*User
Instruction
Manual &
Warranty*

Zippie® IRIS

- CON OPCIÓN DE TRÁNSITO
- SIN OPCIÓN DE TRÁNSITO

Distribuidor:

Este manual debe ser entregado al pasajero de esta silla de ruedas.

Pasajero:

Antes de usar esta silla de ruedas, lea este manual en su totalidad y guárdelo para futura referencia.

*Manual de
Instrucciones
y Garantía
para el
Usuario*

Zippie® IRIS

- AVEC OPTION TRANSIT
- SANS OPTION TRANSIT

Revendeur :

ce manuel doit être remis à l'utilisateur du fauteuil roulant

Utilisateur :

Avant d'utiliser votre fauteuil, lisez attentivement ce manuel dans son intégralité et conservez-le pour pouvoir vous y référer ultérieurement.

*Manuel
d'utilisation
et garantie*

Zippie® IRIS

- MIT TRANSITOPTION
- OHNE TRANSITOPTION

Fachhändler:

Dieses Handbuch muss dem Benutzer des Rollstuhls ausgehändigt werden.

Benutzer:

Vor dem Gebrauch des Rollstuhls lesen Sie bitte das gesamte Handbuch, und bewahren Sie es für zukünftigen Bedarf auf.

*Benutzer-
anweisungen
und Garantie*

Zippie® IRIS

- CON OPZIONE PER IL TRANSITO
- SENZA OPZIONE PER IL TRANSITO

Fornitore:

Il presente manuale va consegnato all'utente della carrozzina.

Utente:

Prima di usare la carrozzina, leggere il presente manuale per intero e conservarlo per riferimento futuro.

*Manuale
dell'utente e
garanzia*



SUNRISE LISTENS

Thank you for choosing a Zippie wheelchair. We want to hear your questions or comments about this manual, the safety and reliability of your chair, and the service you receive from your supplier. Please feel free to write or call us at the address and telephone number below:

SUNRISE MEDICAL
Customer Service Department
7477 East Dry Creek Parkway
Longmont, CO 80503
(303) 218-4500
(800) 333-4000

Let us know your address. This will allow us to keep you up to date with information about safety, new products and options to increase your use and enjoyment of this wheelchair.

FOR ANSWERS TO YOUR QUESTIONS

Your authorized supplier knows your wheelchair best, and can answer most of your questions about chair safety, use and maintenance. For future reference, fill in the following:

Supplier: _____

Address: _____

Telephone: _____

Serial #: _____ Date/Purchased: _____

I. INTRODUCTION	2
II. TABLE OF CONTENTS	3
III. YOUR CHAIR AND ITS PARTS	5
IV. NOTICE - READ BEFORE USE	6
A. Choose the Right Chair & Safety Options	6
B. Review This Manual Often.....	6
C. Warnings.....	6
V. GENERAL WARNINGS	7
A. Weight Limit	7
B. Weight Training	7
C. Getting to Know Your Chair	7
D. To Reduce The Risk of an Accident.....	7
E. Safety Checklist	7
F. Changes & Adjustments.....	8
G. Environmental Conditions	8
H. Terrain.....	8
I. Street Use	8
J. Motor Vehicle Safety.....	9
K. When You Need Help	9
VI. WARNINGS: FALLS & TIP-OVERS	10
A. Center of Gravity.....	10
B. Dressing or Changing Clothes.....	10
C. Wheelies	10
D. Obstacles	11
E. Reaching or Leaning.....	11
F. Moving Backward	12
G. Ramps, Slopes & Sidehills.....	12
H. Transfers.....	13
I. Curbs & Steps	13
J. Stairs	13
K. Escalators	13
VII. WARNINGS: FOR SAFE USE (ATTENDANTS)	14
A. Tilt Use	14
B. Descending a Curb or Single Step	14
C. Climbing a Curb or Single Step.....	14
D. Climbing Stairs	14
E. Descending Stairs.....	15
F. Maintenance	15
G. Transit Use.....	15
VIII. WARNINGS: COMPONENTS & OPTIONS	16
A. Anti-Tip Tubes	16
B. Armrests	16
C. Stroller Handle.....	16
D. Fasteners	16
E. Footrests	17
F. Pneumatic Tires	17

G. Positioning Belts.....	17
H. Power Drive.....	18
I. Push Handles	18
J. Quick-Release Axles.....	18
K. Rear Axles.....	18
L. Rear Wheel Locks	18
M. Modified Seat Systems	19
N. Transit Option.....	19
IX. SET-UP AND ADJUSTMENT	20
A. Swing-Away Hangers and Footrests	20
B. Heavy-Duty, Lift-Off Footrests (optional)	20
C. Contracture Footrest (optional)	20
D. Articulating Legrest (optional)	21
E. Elevating Legrest (optional)	21
F. Caster/Forks Assembly	22
G. Dual-Post Armrest	22
H. Height-Adjustable Armrests (optional).....	23
I. Adjustable Locking Flip-Up Armrests	23
J. Anti-Tip Tubes - Rear.....	24
K. Anti-Tip Tubes - Front.....	24
L. Tilt-In-Space Mechanism	25
M. Height-Adjustable Back with Adjustable Stroller Handle.....	25
N. Stroller Handle Extension	26
O. Reclining Back.....	26
P. Frame Depth.....	26
Q. Frame Width	27
R. Seat Pan	27
S. Cushion Installation	27
T. Rear Axle.....	27
U. Carriage	28
V. Wheel Locks	29
W. Hub Lock Installation	29
X. Attendant Wheel Lock Installation	30
Y. Check Out	30
X. BATTERY TRAY	31
A. How to Make Wheelchair Width Adjustments	31
B. How to Add the Battery Tray Kit.....	32
C. How to Remove Battery Tray Components	32
XI. TROUBLESHOOTING.....	34
XII. MAINTENANCE	35
XIII. SUNRISE LIMITED WARRANTY	37
ESPAÑOL	38
FRANÇAIS.....	75
DEUTSCH	114
ITALIANO	152

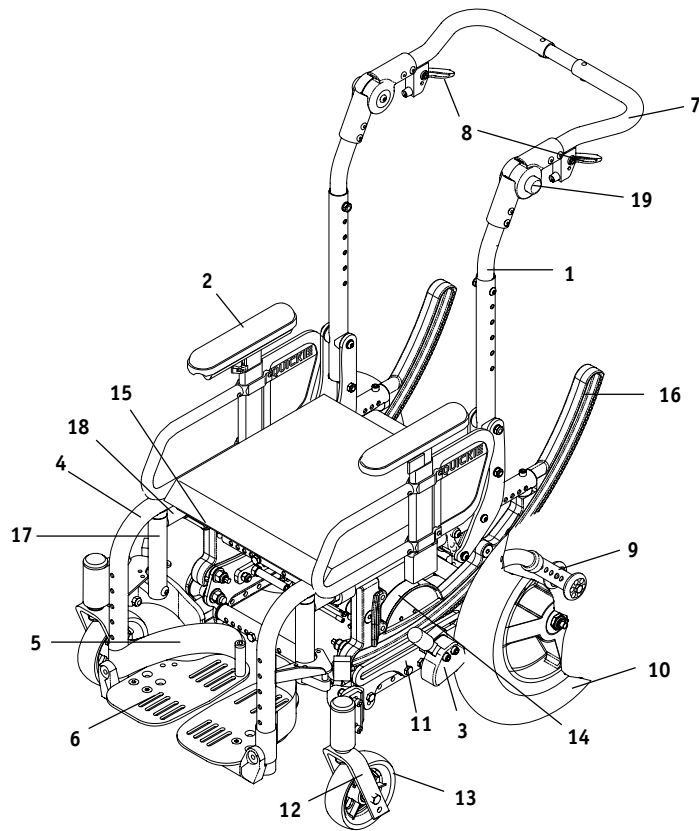

- | | |
|--|--------------------------------------|
| 1. Backpost | 11. Carriage |
| 2. Height-adjustable armrest | 12. Caster fork |
| 3. Wheel locks | 13. Caster tire |
| 4. Swing-away footrest | 14. Tilt indicator |
| 5. Heel loop | 15. Adjustable seat pan |
| 6. Aluminum footplate | 16. Rocker arm |
| 7. Push handle | 17. Hanger receiver |
| 8. Tilt-in-space mechanism release lever | 18. Seat rail |
| 9. Rear anti-tip tube | 19. Adjustable stroller handle hinge |
| 10. 12" Rear wheel | |

A. CHOOSE THE RIGHT CHAIR & SAFETY OPTIONS

Sunrise provides a choice of many wheelchair styles to meet the needs of the wheelchair rider. However, final selection of the type of wheelchair, options and adjustments rests solely with you and your health care advisor. Choosing the best chair and set-up for your safety depends on such things as:

1. Your disability, strength, balance and coordination.
2. The types of hazards you must overcome in daily use (where you live and work, and other places you are likely to use your chair).
3. The need for options for your safety and comfort (such as anti-tip tubes, positioning belts, or special seating systems).

B. REVIEW THIS MANUAL OFTEN

Before using this chair you, and each person who may assist you, should read this entire manual and make sure to follow all instructions. Review the warnings often, until they are second nature to you.

C. WARNINGS

The word **“WARNING”** refers to a hazard or unsafe practice that may cause **severe injury or death** to you or to other persons. The “Warnings” are in four main sections, as follows:

1. V- GENERAL WARNINGS

Here you will find a safety checklist and a summary of risks you need to be aware of before you ride this chair.

2. VI- WARNINGS- FALLS & TIP-OVERS

Here you will learn how to avoid a fall or tip-over while you perform daily activities in your chair.

3. VII- WARNINGS- FOR SAFE USE

Here you will learn about practices for the safe use of your chair

4. VIII- WARNINGS- COMPONENTS & OPTIONS

Here you will learn about the components of your chair and options you can select for safety. Consult your authorized supplier and your health care advisor to help you choose the best set-up and options for safe use.

NOTE- Where they apply, you will also find “Warnings” in other sections of this manual. Heed all warnings in this section. If you fail to do so a fall, tip-over or loss of control may occur and cause severe injury to the rider or others.

A. WEIGHT LIMIT

⚠ WARNING

NEVER exceed the weight limit of 150 pounds for the Zippie IRIS, for combined weight of rider and items carried. If you do exceed the limit, damage to your chair, a fall, tip-over or loss of control may occur and cause severe injury to the rider or others.

B. WEIGHT TRAINING

⚠ WARNING

NEVER use this chair for weight training if total weight (rider plus equipment) exceeds 150 pounds. If you do exceed the limit, damage to your chair, a fall, tip-over or loss of control may occur and cause severe injury to the rider or others.

C. GETTING TO KNOW YOUR CHAIR

⚠ WARNING

Every wheelchair is different. Take the time to learn the feel of this chair before you begin riding. Start slowly, with easy, smooth strokes. If you are used to a different chair, you may use too much force and tip over. If you use too much force, damage to your chair, a fall, tip-over or loss of control may occur and cause severe injury to the rider or others.

D. TO REDUCE THE RISK OF AN ACCIDENT

⚠ WARNING

1. BEFORE riding, you should be trained in the safe use of this chair by your health care advisor.
2. Practice bending, reaching and transfers until you know the limit of your ability. Have someone help you until you know what can cause a fall or tip-over and how to avoid doing so.
3. Be aware that you must develop your own methods for safe use best suited to your level of function and ability.
4. NEVER try a new maneuver on your own until you are sure you can do it safely.
5. Get to know the areas where you plan to use your chair. Look for hazards and learn how to avoid them.
6. Use anti-tip tubes unless you are a skilled rider of this chair and are sure you are not at risk to tip over.

If you fail to heed these warnings damage to your chair, a fall, tip-over or loss of control may occur and cause severe injury to the rider or others.

E. SAFETY CHECKLIST

⚠ WARNING

Before Each Use Of Your Chair:

1. Make sure the chair rolls easily and that all parts work smoothly. Check for noise, vibration, or a change in ease of use. (They may indicate low tire pressure, loose fasteners, or damage to your chair).
2. Repair any problem. Your authorized supplier can help you find and correct the problem.
3. Check to see that both quick-release rear axles are locked. When locked, the axle button will "pop out" fully. If not locked, the wheel may come off and cause you to fall.
4. If your chair has anti-tip tubes, lock them in place.

NOTE– See "Anti-Tip Tubes" (Section VIII) for times you should not use them.

If you fail to heed these warnings damage to your chair, a fall, tip-over or loss of control may occur and cause severe injury to the rider or others.

F. CHANGES & ADJUSTMENTS

WARNING

1. If you modify or adjust this chair, it may increase the risk of a tip-over UNLESS you make other changes as well.
2. Consult your authorized supplier BEFORE you modify or adjust your chair.
3. We recommend that you use anti-tip tubes until you adapt to the change, and are sure you are not at risk to tip over.
4. Unauthorized modifications or use of parts not supplied or approved by Sunrise may change the chair structure. This will void the warranty and may cause a safety hazard.

If you fail to heed these warnings damage to your chair, a fall, tip-over or loss of control may occur and cause severe injury to the rider or others.

G. ENVIRONMENTAL CONDITIONS

WARNING

1. Use extra care if you must ride your chair on a wet or slick surface. If you are in doubt, ask for help.
2. Contact with water or excess moisture may cause your chair to rust or corrode. This could cause your chair to fail.
 - a. Do not use your chair in a shower, pool or other body of water. The chair tubing and parts are not water-tight and may rust or corrode from the inside.
 - b. Avoid excess moisture (for example, do not leave your chair in a damp bathroom while taking a shower).
 - c. Dry your chair as soon as you can if it gets wet, or if you use water to clean it.

If you fail to heed these warnings damage to your chair, a fall, tip-over or loss of control may occur and cause severe injury to the rider or others.

H. TERRAIN

WARNING

1. Your chair is designed for use on firm, even surfaces such as concrete, asphalt and indoor floors and carpeting.
2. Do not operate your chair in sand, loose soil or over rough terrain. This may damage wheels or axles, or loosen fasteners of your chair.

If you fail to heed these warnings damage to your chair, a fall, tip-over or loss of control may occur and cause severe injury to the rider or others.

I. STREET USE

WARNING

In most states, wheelchairs are not legal for use on public roads. Be alert to the danger of motor vehicles on roads or in parking lots.

1. At night, or when lighting is poor, use reflective tape on your chair and clothing.
2. Due to your low position, it may be hard for drivers to see you. Make eye contact with drivers before you go forward. When in doubt, yield until you are sure it is safe.

If you fail to heed these warnings damage to your chair, a fall, tip-over or loss of control may occur and cause severe injury to the rider or others.

J. MOTOR VEHICLE SAFETY

As indicated on the front cover of this user manual, identify whether your chair has been manufactured with the Transit Option installed.

If your chair is **not** equipped with the Transit Option:

WARNING

If your chair is not equipped with Transit Option, this wheelchair does not meet federal standards for motor vehicle seating.

1. NEVER let anyone sit in this chair while in a moving vehicle.
2. ALWAYS secure the rider with proper motor vehicle restraints. In an accident or sudden stop the rider may be thrown from the chair. Wheelchair seat belts will not prevent this, and further injury may result from the belts or straps.
3. NEVER transport this chair in the front seat of a vehicle. It may shift and interfere with the driver.
4. ALWAYS secure this chair so that it cannot roll or shift.
5. Do not use any chair that has been involved in a motor vehicle accident.

If your chair is equipped with the Transit Option:

See section VIII, Part N: Transit Option and section VII, Part G: Transit Use.

If you fail to heed these warnings damage to your chair, a fall, tip-over or loss of control may occur and cause severe injury to the rider or others.

K. WHEN YOU NEED HELP

WARNING

For The Rider:

Make sure that each person who helps you reads and follows all warnings and instructions that apply.

For Attendants:

1. Work with the rider's doctor, nurse or therapist to learn safe methods best suited to your abilities and those of the rider.
2. Tell the rider what you plan to do, and explain what you expect the rider to do. This will put the rider at ease and reduce the risk of an accident.
3. Make sure the chair has push handles. They provide secure points for you to hold the rear of the chair to prevent a fall or tip-over. Check to make sure push handle grips will not rotate or slip off.
4. To prevent injury to your back, use good posture and proper body mechanics. When you lift or support the rider or tilt the chair, bend your knees slightly and keep your back as upright and straight as you can.
5. Remind the rider to lean back when you tilt the chair backward.
6. When you descend a curb or single step, slowly lower the chair in one easy movement. Do not let the chair drop the last few inches to the ground. This may damage the chair or injure the rider.
7. To avoid tripping, unlock and rotate anti-tip tubes up, out of the way. ALWAYS lock the rear wheels and lock anti-tip tubes in place if you must leave the rider alone, even for a moment. This will reduce the risk of a tip over or loss of control of the chair.

If you fail to heed these warnings damage to your chair, a fall, tip-over or loss of control may occur and cause severe injury to the rider or others.

A. CENTER OF GRAVITY

⚠ WARNING

The point where this chair will tip forward, back, or to the side depends on its center of gravity and stability. How your chair is set up, the options you select and the changes you make may affect the risk of a fall or tip-over.

1. The Most Important Adjustments Are:
 - a. The position of the rear wheels. The more you move the rear wheels forward, the more likely your chair will tip over backward.
 - b. The position of the carriage.
2. The Center Of Gravity Is Also Affected By:
 - a. A change in the set-up of your chair, including:
 - The seat height and seat angle.
 - Backrest angle.
 - b. A change in your body position, posture or weight distribution.
 - c. Riding your chair on a ramp or slope.
 - d. The use of a back pack or other options, and the amount of added weight.
3. To Reduce The Risk Of An Accident:
 - a. Consult your doctor, nurse or therapist to find out what axle and caster position is best for you.
 - b. Consult your authorized supplier BEFORE you modify or adjust this chair. Be aware that you may need to make other changes to correct the center of balance.
 - c. Have someone help you until you know the balance points of your chair and how to avoid a tip-over.
 - d. Use anti-tip tubes.
 - e. Never allow the presence of a second occupant climbing or standing on a component of the chair.

If you fail to heed these warnings damage to your chair, a fall, tip-over or loss of control may occur and cause severe injury to the rider or others.

B. DRESSING OR CHANGING CLOTHES

⚠ WARNING

Your weight may shift if you dress or change clothes while seated in this chair.

To reduce the risk of a fall or tip-over:

1. Rotate the front casters until they are as far forward as possible. This makes the chair more stable.
2. Lock anti-tip tubes in place. (If your chair does not have anti-tip tubes, back it up against a wall and lock both rear wheels).

If you fail to heed these warnings damage to your chair, a fall, tip-over or loss of control may occur and cause severe injury to the rider or others.

C. WHEELIES

Because of the ability to adjust the center of gravity and changes in center of gravity that will result from operating the tilt in space feature of this chair, as a user, do not perform wheelies in the IRIS wheelchair.

⚠ WARNING

Doing a "wheelie" means: balancing on the rear wheels of your chair, while the front casters are in the air. It is dangerous to do a "wheelie" as a fall or tip-over may occur.

If you fail to heed these warnings damage to your chair, a fall, tip-over or loss of control may occur and cause severe injury to the rider or others.

D. OBSTACLES

⚠ WARNING

Obstacles and road hazards (such as potholes and broken pavement) can damage your chair and may cause a fall, tip-over or loss of control.

To avoid these risks:

1. Keep a lookout for danger – scan the area well ahead of your chair as you ride.
2. Make sure the floor areas where you live and work are level and free of obstacles.
3. Remove or cover threshold strips between rooms.
4. Install a ramp at entry or exit doors. Make sure there is not a drop off at the bottom of the ramp.
5. To Help Correct Your Center Of Balance:
 - a. Lean your upper body FORWARD slightly as you go UP over an obstacle.
 - b. Press your upper body BACKWARD as you go DOWN from a higher to a lower level.
6. If your chair has anti-tip tubes, lock them in place before you go UP over an obstacle.
7. Keep both of your hands on the handrims as you go over an obstacle.
8. Never push or pull on an object (such as furniture or a doorjamb) to propel your chair.

If you fail to heed these warnings damage to your chair, a fall, tip-over or loss of control may occur and cause severe injury to the rider or others.

E. REACHING OR LEANING

⚠ WARNING

If you reach or lean it will affect the center of balance of your chair. This may cause you to fall or tip over. When in doubt, ask for help or use a device to extend your reach.

1. NEVER reach or lean if you must shift your weight sideways or rise up off the seat.
2. NEVER reach or lean if you must move forward in your seat to do so. Always keep your buttocks in contact with the backrest.
3. NEVER reach with both hands (you may not be able to catch yourself to prevent a fall if the chair tips).
4. NEVER reach or lean to the rear unless your chair has anti-tip tubes locked in place.
5. DO NOT reach or lean over the top of the seat back. This may damage one or both backrest tubes and cause you to fall.
6. If You Must Reach Or Lean:
 - a. Do not lock the rear wheels. This creates a tip point and makes a fall or tip-over more likely.
 - b. Do not put pressure on the footrests.

NOTE– Leaning forward puts pressure on the footrests and may cause the chair to tip if you lean too far.

- c. Move your chair as close as you can to the object you wish to reach.
- d. Do not try to pick up an object from the floor by reaching down between your knees. You are less likely to tip if you reach to the side of your chair.
- e. Rotate the front casters until they are as far forward as possible. This makes the chair more stable.

NOTE– To do this: Move your chair past the object you want to reach, then back up alongside it. Backing up will rotate the casters forward.

- f. Firmly grasp a rear wheel or an armrest with one hand. This will help to prevent a fall if the chair tips.

If you fail to heed these warnings damage to your chair, a fall, tip-over or loss of control may occur and cause severe injury to the rider or others.

F. MOVING BACKWARD**⚠ WARNING**

Use extra care when you move your chair backward. Your chair is most stable when you propel yourself forward. You may lose control or tip over if one of the rear wheels hits an object and stops rolling.

1. Propel your chair slowly and smoothly.
2. If your chair has anti-tip tubes, make sure to lock them in place.
3. Stop often and check to be sure your path is clear.

If you fail to heed these warnings damage to your chair, a fall, tip-over or loss of control may occur and cause severe injury to the rider or others.

G. RAMPS, SLOPES & SIDEHILLS**⚠ WARNING**

Riding on a slope, which includes a ramp or sidehill, will change the center of balance of your chair. Your chair is less stable when it is at an angle. Anti-tip tubes may not prevent a fall or tip-over.

1. Do not use your chair on a slope steeper than 10%. (A 10% slope means: one foot in elevation for every ten feet of slope length.)
2. Always go as straight up and as straight down as you can. (Do not “cut the corner” on a slope or ramp.)
3. Do not turn or change direction on a slope.
4. Always stay in the CENTER of the ramp. Make sure ramp is wide enough that you are not at risk that a wheel may fall over the edge.
5. Do not stop on a steep slope. If you stop, you may lose control of your chair.
6. NEVER use rear wheel locks to try to slow or stop your chair. This is likely to cause your chair to veer out of control.
7. Beware Of:
 - a. Wet or slippery surfaces.
 - b. A change in grade on a slope (or a lip, bump or depression). These may cause a fall or tip-over.
 - c. A drop-off at the bottom of a slope. A drop-off of as small as 3/4 inch can stop a front caster and cause the chair to tip forward.
8. To Reduce The Risk Of A Fall Or Tip-Over:
 - a. Lean or press your body UPHILL. This will help adjust for the change in the center of balance caused by the slope or sidehill.
 - b. Keep pressure on the handrims to control your speed on a down slope. If you go too fast you may lose control.
 - c. Ask for help any time you are in doubt.
9. Ramps At Home & Work - For your safety, ramps at home and work must meet all legal requirements for your area. We recommend:
 - a. Width: At least four feet wide.
 - b. Guardrails: To reduce the risk of a fall, sides of ramp must have guardrails (or raised borders at least three inches high).
 - c. Slope: Not more than a 10% grade.
 - d. Surface: Flat and even, with a thin carpet or other non-skid material. (Make sure there is no lip, bump or depression.)
 - e. Bracing: Ramps must be STURDY. You may need bracing so ramps do not “bow” when you ride on them.
 - f. Avoid A Drop Off: You may need a section at the top or bottom to smooth out the transition.

If you fail to heed these warnings damage to your chair, a fall, tip-over or loss of control may occur and cause severe injury to the rider or others.

H. TRANSFER

⚠ WARNING

It is dangerous to transfer on your own. It requires good balance and agility. Be aware that there is a point during every transfer when the wheelchair seat is not below you. To Avoid A Fall:

1. Work with your health care advisor to learn safe methods.
 - a. Learn how to position your body and how to support yourself during a transfer.
 - b. Have someone help you until you know how to do a safe transfer on your own.
2. Lock the rear wheels before you transfer. This keeps the rear wheels from rolling.

NOTE– This will NOT keep your chair from sliding away from you or tipping.

3. Make sure to keep pneumatic tires properly inflated. Low tire pressure may allow the rear wheel locks to slip.
4. Move your chair as close as you can to the seat you are transferring to.
If possible, use a transfer board.
5. Rotate the front casters until they are as far forward as possible.
6. If you can, remove or swing footrests out of the way.
 - a. Make sure your feet do not catch in the space between the footrests.
 - b. Avoid putting weight on the footrests as this may cause the chair to tip.
7. Make sure armrests are out of the way and do not interfere.
8. Transfer as far back onto the seat surface as you can. This will reduce the risk that the chair will tip or move away from you.

If you fail to heed these warnings damage to your chair, a fall, tip-over or loss of control may occur and cause severe injury to the rider or others.

I. CURBS & STEPS

⚠ WARNING

1. Each person who helps you should read and follow the warnings “For Safe Use” (Section VII) and “For Attendants” (Section V, Part K).
2. Do not try to climb or descend a curb or step alone.
3. Unlock and rotate anti-tip tubes up, out of the way, so they do not interfere.
4. Do not try to climb a high curb or step UNLESS you have help. Doing so may cause your chair to exceed its balance point and tip over.
5. Go straight up and straight down a curb or step. If you climb or descend at an angle, a fall or tip-over is likely.
6. Be aware that the impact of dropping down from a curb or step can damage your chair or loosen fasteners.

If you fail to heed these warnings damage to your chair, a fall, tip-over or loss of control may occur and cause severe injury to the rider or others.

J. STAIRS

⚠ WARNING

1. NEVER use this chair on stairs UNLESS you have someone to help you. Doing so is likely to cause a fall or tip-over.
2. Persons who help you should read and follow the warnings “For Attendants” (Section V, Part K), and “For Safe Use” (Section VII).

If you fail to heed these warnings damage to your chair, a fall, tip-over or loss of control may occur and cause severe injury to the rider or others.

K. ESCALATORS

⚠ WARNING

NEVER use this chair on an escalator, even with an attendant. If you do, a fall or tip-over is likely.

If you fail to heed these warnings damage to your chair, a fall, tip-over or loss of control may occur and cause severe injury to the rider or others.

⚠ WARNING

Before you assist a rider, be sure to read the warnings “For Attendants” in Section V, Part K and follow all instructions that apply. Be aware that you will need to learn safe methods best suited to your abilities.

A. TILT USE**⚠ WARNING**

In preparation to operate the tilt:

- Always verify that the arms of the rider are stable on the armrests or within the armrests.
- Always verify that the legs of the rider are stable on the footrest/legrest.
- Never place hands, feet or foreign objects into the tilt mechanism.
- Never push or propel the chair with the seat tilted in a forward position.
- Never add chair accessories that are not specifically designed for Zippie IRIS.
- Never exceed a tilted position that aligns the backrest parallel to the ground.

B. DESCENDING A CURB OR SINGLE STEP**⚠ WARNING**

Follow these steps to help a rider descend a curb or single step going BACKWARD:

1. Stay at the rear of the chair.
2. Several feet before you reach the edge of the curb or step, turn the chair around and pull it backward.
3. While looking over your shoulder, carefully step back until you are off the curb or stair and standing on the lower level.
4. Pull the chair toward you until the rear wheels reach the edge of the curb or step. Then allow the rear wheels to slowly roll down onto the lower level.
5. When the rear wheels are safely on the lower level, tilt the chair back to its balance point. This will lift the front casters off the curb or step.
6. Keep the chair in balance and take small steps backward. Turn the chair around and gently lower front casters to the ground.

If you fail to heed these warnings damage to your chair, a fall, tip-over or loss of control may occur and cause severe injury to the rider or others.

C. CLIMBING A CURB OR SINGLE STEP**⚠ WARNING**

Follow these steps to help the rider climb a curb or single step going FORWARD:

1. Stay behind the chair.
2. Face the curb and tilt the chair up on the rear wheels so that the front casters clear the curb or step.
3. Move forward, placing the front casters on the upper level as soon as you are sure they are past the edge.
4. Continue forward until the rear wheels contact the face of the curb or step. Lift and roll the rear wheels to the upper level.

If you fail to heed these warnings damage to your chair, a fall, tip-over or loss of control may occur and cause severe injury to the rider or others.

D. CLIMBING STAIRS**⚠ WARNING**

1. Use at least two attendants to move a chair and rider up stairs.
2. Move the chair and rider BACKWARD up the stairs.
3. The person at the rear is in control. He or she tilts the chair back to its balance point.
4. A second attendant at the front should firmly grasp the hanger receiver or frontmost part of the seat rail and lift the chair up and over one stair at a time.

- The attendants move to the next stair up. Repeat for each stair, until you reach the landing.

If you fail to heed these warnings damage to your chair, a fall, tip-over or loss of control may occur and cause severe injury to the rider or others.

E. DESCENDING STAIRS

⚠ WARNING

- Use at least two attendants to move a chair and rider down stairs.
- Move the chair and rider FORWARD down the stairs.
- The person at the rear is in control. He or she tilts the chair to the balance point of the rear wheels and rolls it to the edge of the top step.
- A second attendant stands on the third step from the top and grasps the hanger receiver or frontmost part of the seat rail. He or she lowers the chair one step at a time by letting the rear wheels roll over the stair edge.
- The attendants move to the next stair down. Repeat for each stair, until you reach the landing.

If you fail to heed these warnings damage to your chair, a fall, tip-over or loss of control may occur and cause severe injury to the rider or others.

F. MAINTENANCE

⚠ WARNING

- Inspect and maintain this chair strictly per chart in section XI. Maintenance.
- If you detect a problem, make sure to service or repair the chair before use.
- At least once a year, have a complete inspection, safety check and service of your chair made by an authorized supplier.

If you fail to heed these warnings damage to your chair, a fall, tip-over or loss of control may occur and cause severe injury to the rider or others. For additional maintenance information see Section XI: Maintenance.

G. TRANSIT USE

Refer also to section VIII, part N and section V, part J for additional transit option and motor vehicle warnings.

⚠ WARNING

- If possible and feasible, the rider should transfer to the Original Equipment Manufacturer vehicle seat and use the vehicle restraint.
- If the wheelchair is used for transport, it must be used in a forward-facing seating position.
- The rider must not weigh more than 150 lbs.
- The figure to the right shows the locations of the wheelchair securement points, front (A) and back (B).
- Use only with Wheelchair Tie down and Occupant Restraint Systems (WTORS) that have been installed in accordance with the manufacturer's instructions and SAE J2249.
- Attach WTORS to securement points in accordance with the manufacturer's instructions and SAE J2249.
- Attach occupant restraints in accordance with the manufacturer's instructions and SAE J2249.

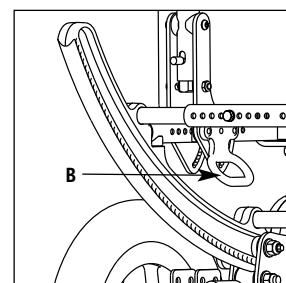
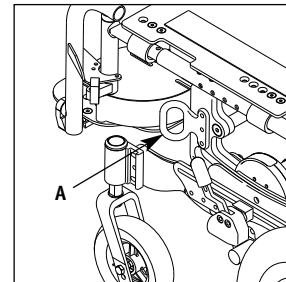

A. ANTI-TIP TUBES (OPTIONAL)**⚠ WARNING**

Anti-tip tubes can help keep your chair from tipping over backward in most normal conditions.

1. Sunrise Recommends Use Of Anti-Tip Tubes:
 - a. UNLESS you are a skilled rider of this chair and are sure you are not at risk to tip over.
 - b. Each time you modify or adjust your chair. The change may make it easier to tip backward. Use anti-tip tubes until you adapt to the change, and are sure you are not at risk to tip over.
2. When locked in place (in the “down” position) anti-tip tubes should be BETWEEN 1 1/2 to 2 inches off the ground.
 - a. If set too HIGH, they may not prevent a tip-over.
 - b. If set too LOW, they may “hang up” on obstacles you can expect in normal use. If this occurs, you may fall or your chair may tip over.
3. Keep Anti-Tip Tubes Locked In Place UNLESS:
 - a. You have an attendant, or
 - b. You have to climb or descend a curb, or overcome an obstacle, and can safely do so without them. At these times, make sure anti-tip tubes are up, out of the way.

If you fail to heed these warnings damage to your chair, a fall, tip-over or loss of control may occur and cause severe injury to the rider or others.

B. ARMRESTS**⚠ WARNING**

Armrests will not bear the weight of this chair.

1. NEVER lift this chair by its armrests. They may come loose or break.
2. Lift this chair only by non-detachable parts of the main frame.

If you fail to heed these warnings damage to your chair, a fall, tip-over or loss of control may occur and cause severe injury to the rider or others.

C. STROLLER HANDLE**⚠ WARNING**

1. Always keep hands away from the locking mechanism located at the bottom of the back canes when folding the back down or pulling it back up.
2. Always keep fingers away from the interior of the hinge when readjusting the adjustable stroller handle.

D. FASTENERS**⚠ WARNING**

Many of the screws, bolts and nuts on this chair are special high-strength fasteners. Use of improper fasteners may cause your chair to fail.

1. ONLY use fasteners provided by an authorized supplier (or ones of the same type and strength, as indicated by the markings on the heads).
2. Over- or under-tightened fasteners may fail or cause damage to chair parts.
3. If bolts or screws become loose, tighten them as soon as you can.

If you fail to heed these warnings damage to your chair, a fall, tip-over or loss of control may occur and cause severe injury to the rider or others.

E. FOOTRESTS

⚠ WARNING

Footrests will not bear the weight of this chair

1. At the lowest point, footrests should be AT LEAST 2 1/2 INCHES off the ground. If set too LOW, they may “hang up” on obstacles you can expect to find in normal use. This may cause the chair to stop suddenly and tip forward.
2. To Avoid A Trip Or Fall When You Transfer:
 - a. Make sure your feet do not “hang up” or get caught in the space between the footrests.
 - b. Avoid putting weight on the footrests, as the chair may tip forward.
3. NEVER lift this chair by the footrests. Footrests detach and will not bear the weight of this chair. Lift this chair only by non-detachable parts of the main frame.

If you fail to heed these warnings damage to your chair, a fall, tip-over or loss of control may occur and cause severe injury to the rider or others.

F. PNEUMATIC TIRES

⚠ WARNING

Proper inflation extends the life of your tires and makes your chair easier to use.

1. Do not use this chair if any of the tires is under- or over-inflated. Check weekly for proper inflation level, as listed on the tire sidewall.
2. Low pressure in a rear tire may cause the wheel lock on that side to slip and allow the wheel to turn when you do not expect it.
3. Low pressure in any of the tires may cause the chair to veer to one side and result in a loss of control.
4. Over-inflated tires may burst.

If you fail to heed these warnings damage to your chair, a fall, tip-over or loss of control may occur and cause severe injury to the rider or others.

G. POSITIONING BELTS (OPTIONAL)

⚠ WARNING

Use positioning belts ONLY to help support the rider's posture. Improper use of these belts may cause severe injury to or death of the rider.

1. Make sure the rider can not slide down in the wheelchair seat. If this occurs, the rider may suffer chest compression or suffocate due to pressure from the belts.
2. The belts must be snug, but must not be so tight that they interfere with breathing. You should be able to slide your open hand, flat, between the belt and the rider.
3. A pelvic wedge or a similar device can help keep the rider from sliding down in the seat. Consult with the rider's doctor, nurse or therapist to find out if the rider needs such a device.
4. Use positioning belts only with a rider who can cooperate. Make sure the rider can easily remove the belts in an emergency.
5. NEVER Use Positioning Belts:
 - a. As a patient restraint. A restraint requires a doctor's order.
 - b. On a rider who is comatose or agitated.
 - c. As a motor vehicle restraint. In an accident or sudden stop the rider may be thrown from the chair. Wheelchair seat belts will not prevent this, and further injury may result from the belts or straps.

If you fail to heed these warnings damage to your chair, a fall, tip-over or loss of control may occur and cause severe injury to the rider or others.

H. POWER DRIVE**⚠ WARNING**

Do not install a power drive on any Zippie wheelchair. If you do:

1. It will affect the center of balance of your chair and may cause a fall or tip-over.
2. It will alter the frame and void the warranty.

If you fail to heed these warnings damage to your chair, a fall, tip-over or loss of control may occur and cause severe injury to the rider or others.

I. PUSH HANDLES**⚠ WARNING**

When you have a attendant, make sure that this chair has push handles.

1. Push handles provide secure points for an attendant to hold the rear of this chair, to prevent a fall or tip-over. Make sure to use push handles when you have an attendant.
2. Check to make sure push handle grips will not rotate or slip off.

If you fail to heed these warnings damage to your chair, a fall, tip-over or loss of control may occur and cause severe injury to the rider or others.

J. QUICK-RELEASE AXLES**⚠ WARNING**

1. Do not use this chair UNLESS you are sure that both quick-release rear axles are locked. An unlocked axle may come off during use and cause a fall.
2. An axle is not locked until the quick-release button pops out fully. An unlocked axle may come off during use, resulting in a fall, tip-over or loss of control and cause severe injury to the rider or others.

If you fail to heed these warnings damage to your chair, a fall, tip-over or loss of control may occur and cause severe injury to the rider or others.

K. REAR AXLES**⚠ WARNING**

A change in set-up of the rear wheels will affect the center of balance of your chair.

1. The farther you move the rear axles FORWARD, the more likely it is that your chair will tip over backward.
2. Consult your doctor, nurse or therapist to find the best rear axle set-up for your chair. Do not change the set-up UNLESS you are sure you are not at risk to tip over.
3. Adjust the rear wheel locks after you make any change to the rear axles.
 - a. If you fail to do so, the locks may not work.
 - b. Make sure lock arms embed in tires at least 1/8 inch when locked.

If you fail to heed these warnings damage to your chair, a fall, tip-over or loss of control may occur and cause severe injury to the rider or others.

L. REAR WHEEL LOCKS**⚠ WARNING**

Rear wheel locks are NOT designed to slow or stop a moving wheelchair.

Use them only to keep the rear wheels from rolling when your chair is at a complete stop.

1. NEVER use rear wheel locks to try to slow or stop your chair when it is moving. Doing so may cause you to veer out of control.
2. To keep the rear wheels from rolling, always set both rear wheel locks when you transfer to or from your chair.
3. Low pressure in a rear tire may cause the wheel lock on that side to slip and may allow the wheel to turn when you do not expect it.
4. Make sure lock arms embed in tires at least 1/8 inch when locked. If you fail to do so, the locks may not work.

If you fail to heed these warnings damage to your chair, a fall, tip-over or loss of control may occur and cause severe injury to the rider or others.

M. MODIFIED SEAT SYSTEMS

⚠ WARNING

Use of a seat system not approved by Sunrise may alter the center of balance of this chair. This may cause the chair to tip over.

1. Do not change the seat system of your chair UNLESS you consult your authorized supplier first.
2. Use of a non-validated system (wheelchair base and seating), as a seat in a motor vehicle could result in increased risk of severe injury or death in a vehicular mishap.
 - Only a complete system (wheelchair base and seating) can be validated for use as a seat in a motor vehicle.
 - The seating provided may or may not be appropriate for use as a seat in a motor vehicle in combination with this wheelchair base.
 - Before using this system as a seat in a motor vehicle, you should verify that the seating manufacturer has validated the seating in combination with this wheelchair base.
 - Before using this system as a seat in a motor vehicle, you should read and comply with all instructions for use provided by both Sunrise Medical and the seating manufacturer as well as the instructions for use of any other component or accessory manufacturer.

If you fail to heed these warnings damage to your chair, a fall, tip-over or loss of control may occur and cause severe injury to the rider or others.

N. TRANSIT OPTION

⚠ WARNING

1. Use only Wheelchair Tiedown and Occupant Restraint Systems (WTORS) which meet the requirements of SAE J2249 Recommended Practice - Wheelchair Tiedown and Occupant Restraint Systems For Use in Motor Vehicles. Do not use WTORS designed to rely on the wheelchair structure to transfer occupant restraint loads to the vehicle.
2. The wheelchair has been dynamically tested in a forward-facing mode for a 30 mph frontal impact test. The wheelchair must be forward-facing during transport.
3. In order to reduce the potential of injury to vehicle occupants, wheelchair-mounted accessories, such as trays and respiratory equipment, should be removed and secured separately.
4. Postural supports and positioning devices should not be relied on for occupant restraint.
5. Do not alter or substitute wheelchair frame parts, components or seating.
6. Sudden stops or impacts can structurally damage your chair. Chairs involved in such incidents should be replaced.

If you fail to heed these warnings damage to your chair, a fall, tip-over or loss of control may occur and cause severe injury to the rider or others.

NOTE– Setting the wheelchair on a table or on a flat surface, such as a workbench, helps make these procedures easier.

NOTE ON TORQUE SETTING– A torque setting is the optimum tightening which should be made on a particular fastener. A torque wrench which measures in./lbs. should be used when tightening fasteners on Zippie wheelchairs. Unless otherwise noted, use a torque setting of 60 in./lbs. When setting up this wheelchair.

A. SWING-AWAY HANGERS AND FOOTRESTS 60°, 70°, 70°V, 80°, OR 90°

1. Installation

- Place swing-away pivot saddle (A) into the receiver (B) on front frame tube with the footrest facing outward from frame.
- Rotate the footrest inward until it locks into place on locking bolt (C).

2. Removal

- To remove footrest, push release latch (D) toward the frame.
- Rotate footrest outward and lift.

3. Height Adjustment with Extension Tube

- Remove both bolts (E) in the hanger frame tube.
- Reposition footrest height.
- Re-tighten all bolts (E).

4. Height Adjustment, Front Mount

- Loosen and remove the retaining bolt (F) in the frame tube.
- Position footplate upward or downward in predrilled holes on hanger tube.
- Reinsert bolt (F) and tighten.

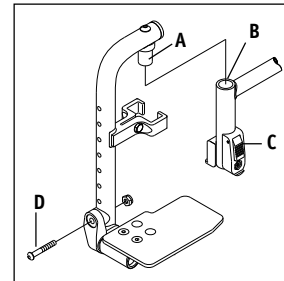
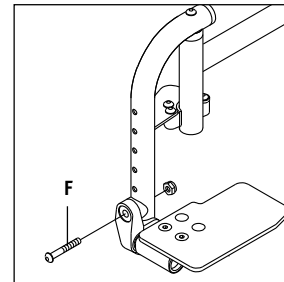
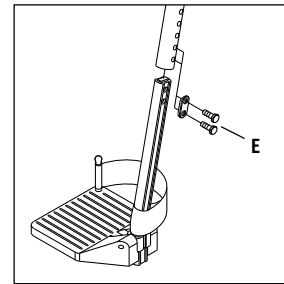
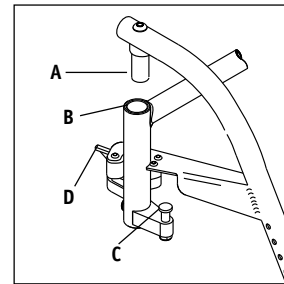

B. HEAVY-DUTY, LIFT-OFF FOOTRESTS (OPTIONAL): 70°, 80°, 90°

1. Installation

Slide pivot saddle (A) into receiver (B) on front frame tube until it locks into place.

2. Removal

To remove footrest, push release latch (C) while lifting up footrest from receiver.

3. Height-Adjustment, Front Mount

- Loosen and remove the retaining bolt (D) in the footrest mounting bracket.
- Position footplate upward or downward in predrilled holes on hanger tube.
- Reinsert bolt and tighten.

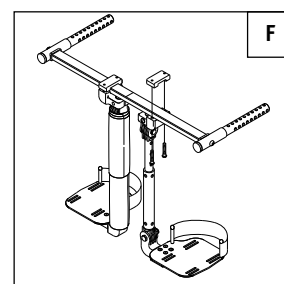
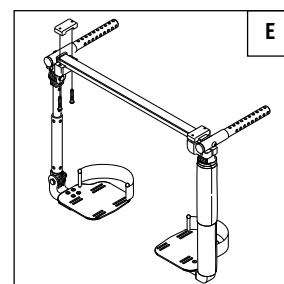

C. CONTRACTURE FOOTREST (OPTIONAL)

1. Lateral Mount

Can be mounted laterally as shown in illustration (E).

2. Center Mount

Can be mounted in the center as shown in illustration (F).

3. Height Adjustment

- Loosen and remove the retaining bolt (G) in the footrest mounting bracket.
- Slide the lower tube upward or downward to the desired position until predrilled holes on hanger tubes are aligned.
- Reinsert bolt and tighten.

4. Footrest Angle Adjustment

- Loosen the retaining bolt (H) in the adjustment locking joint.
- Position footrest forward or rearward in desired angle.
- Retighten the bolt.

5. Footplate Angle Adjustment

- Loosen the retaining bolt (I) in the footplate locking joint.
- Position footplate upward or downward in desired angle.
- Retighten the bolt.

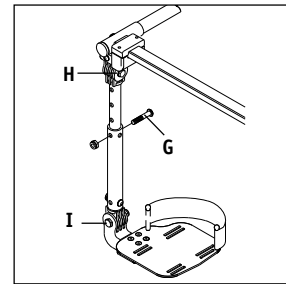

D. ARTICULATING LEGREST (OPTIONAL)

1. Installation or Removal

To install or remove Articulating Legrest (ALR) see instructions for Swing-away Footrest installation.

2. Elevation Adjustment

- To raise legrest, lift to desired position. Legrest will automatically lock in place.
- To lower legrest, while seated in chair, press release lever (A) down and lower legrest to desired position. Legrest will automatically lock in place.

3. Height Adjustment of the Calf Pad

- Rotate the tube clamp (B) towards the outside.
- Slide it up or down.
- Rotate it back in the desired indented position.

4. Height Adjustment with Extension Tube

- Remove the bolt (C) in the hanger frame tube.
- Reposition footrest height.
- Align the tube clamp with the selected bolt.
- Re-tighten the bolt (C).

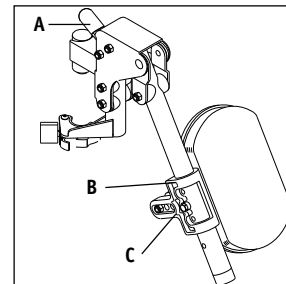

E. ELEVATING LEGREST (OPTIONAL)

1. Installation or Removal

To install or remove Elevating Legrest (ELR) see instructions for Swing-away Footrest installation.

2. Elevation Adjustment

- To raise legrest, lift to desired position. Legrest will automatically lock in place.
- To lower legrest, while seated in chair, press release lever (D) down and lower legrest to desired position. Legrest will automatically lock in place.

3. Height Adjustment of the Calf Pad.

- Loosen the retaining nut (E) located at the back of the calf pad bracket assembly.
- Slide the calf pad bracket assembly up or down.
- Tighten it in the desired position.

4. Height Adjustment with Extension Tube

- Loosen both bolts (F) in the hanger frame tube.
- Reposition footrest height.
- Re-tighten all bolts (F).

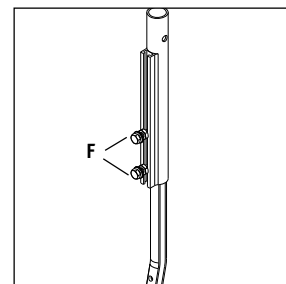
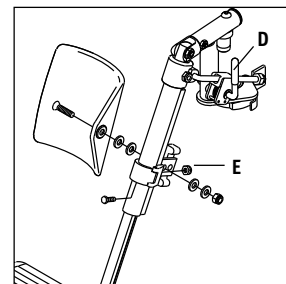

F. CASTER/FORKS ASSEMBLY

1. Installation

- Remove dust cover (A) from caster housing. Pry dust cover off using a back and forth motion.
- Caster assembly holds one nut (B) and one washer (immediately below the nut). Remove nut and washer.
- Insert caster stem (C) into caster housing (D) and place washer on stem.
- Replace nut (B) on caster stem and tighten until all play is removed; then loosen approximately 1/8 turn, yet still allowing for free rotation.
- Replace dust cover to caster housing.

2. Caster Angle Adjustment

For optimum performance, the caster housing should always be at a 90° angle to the floor (perpendicular to the ground). This adjustment is made with an eccentric (offset) attachment bolt mechanism.

- To change the angle, place the chair on a flat surface (such as a table).
- Remove the bolt nuts (G) from the back side of the caster plate. The caster plate is slotted at the top and bottom for adjustment.
- Place a large right triangle against the table surface and the front surface of the caster bearing housing to align the caster stem rotational axis perpendicular to the floor surface.
- Rotate the eccentric washers (E) independently until they fall into position.
- When the alignment is correct, retighten the two retaining bolts.
- Repeat the process for the other caster.

NOTE– Use a torque setting of 100 in.-lbs. when setting-up caster plate.

3. Height Adjustment

- Loosen and remove bolt (F).
- Set axle at desired height using pre-set holes in the fork.
- Replace and tighten bolt.
- Repeat on other side.

NOTE– The frame must be kept horizontal when height is adjusted. Refer to matrix in the ordering guide for proper setting.

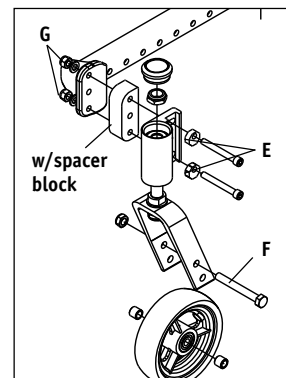
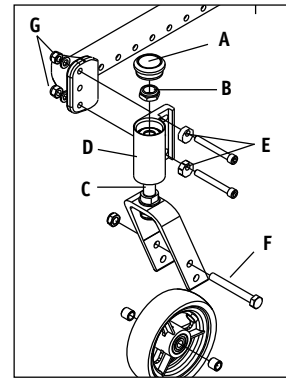

G. DUAL-POST ARMRESTS

1. Installation or Removal

- The assembly is held securely in place when the securing levers (A, B) are facing outside.
- Pull securing levers forward to release.
- Insert or remove armrest.
- Return securing levers to locked position.

2. Height-Adjustment (optional)

- Release the upper securing lever (C).
- Set armrest at desired height.
- Return securing lever to locked position.
- Move armrest up or down to allow armrest to snap into place.

3. Flip Back (optional)

- Release the front securing lever only (A).
- Flip the armrest back, it remains attached to the rear receiver.
- Move armrest down into place.
- Return securing lever to locked position.

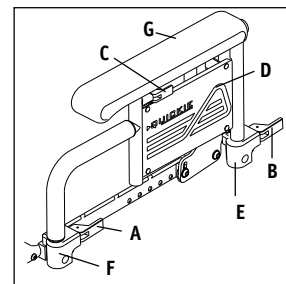

Dual Post Armrest

- A. Front release latch
- B. Rear release latch
- C. Upper securing lever
- D. Armrest panel
- E. Rear receiver
- F. Front receiver
- G. Armrest pad

H. HEIGHT-ADJUSTABLE ARMREST (OPTIONAL)

1. Installation

- Slide the outer armpost (1) down into the receiver (2) mounted to the wheelchair frame.
- The armrest will automatically lock into place.

2. Height Adjustment

- Release the upper securing lever (10).
- Slide armrest pad up or down to desired height.
- Return lever to locked position.
- Push arm pad until upper armpost locks firmly into place.

3. Removing Armrest

- Pull the release lever back (3).
- Slide armrest out from the receiver (2).

4. Replacing Armrest

- Slide armrest back into receiver (2).
- Push down firmly until the release lever (3) locks back in place.

5. Adjusting Armrest Receiver Fit

To tighten or loosen the fit of the outer armpost in the receiver:

- Loosen all four bolts (9) on the sides of the receiver (2).
- With the armrest in the receiver, squeeze the receiver to achieve the desired fit.
- Tighten all four bolts (9).

6. Adjusting Inner Armpost Fit

- Two set screws are installed in the outer armpost (7).
- Turn the set screws in or out until the desired fit is achieved.

I. ADJUSTABLE LOCKING FLIP-UP ARMRESTS

1. Flip up and down

- Release the upper securing lever (B).
- Flip the armrest back, it remains attached to the back post.
- Move armrest down into place.
- The lever (B) locks itself in position automatically.

2. Height Adjustment

- Loosen bolts (C, D) and remove flip-back tube.
- Loosen bolts (E, F) and remove clamp (J).
- Move the clamp (J) up or down to the desired position.
- Tighten bolts (E, F).
- Install the flip-back tube back in place and tighten bolts (C,D).
- Repeat the process for the other armrest.

3. Angle-Adjustment

- Loosen bolt (D).
- Set armrest at desired angle using preset holes in armrest angle plate.
- Tighten bolt.

4. Length-Adjustment (optional)

- Remove foam grip or armpad (A) from armrest.
- Loosen screw (G) in the adjustable flip-up tube.
- Reposition the sleeve (I) at the desired length.
- Re-tighten the screw (G).
- Put foam grip or armpad back in place.

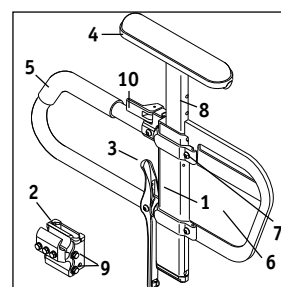

Height-Adjustable Armrest

- Outer armpost
- Standard receiver
- Armrest release lever
- Armrest pad
- Transfer bar
- Side panel
- Outer armpost tension adjustment set screws
- Inner armpost
- Receiver adjustment bolts
- Upper release Lever

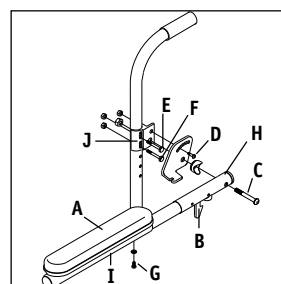

Adjustable Locking Flip-Up

- Armrest Pad
- Upper Securing Lever
- Flip-back tube
- Sleeve
- Clamp

J. ANTI-TIP TUBES- REAR

Anti-tip tubes are recommended for all wheelchairs.

NOTE– Use a torque setting of 96 in.-lbs. when setting-up anti-tip tubes.

1. Inserting Anti-Tip Tubes Into Receivers

- Press the rear anti-tip release pin (A) on the anti-tip tube so that both release pins are drawn inside.
- Insert the anti-tip tube into the receiver (B).
- Turn the anti-tip tube down until release pin protrudes through the receiver mounting hole.
- Insert second anti-tip tube the same way.

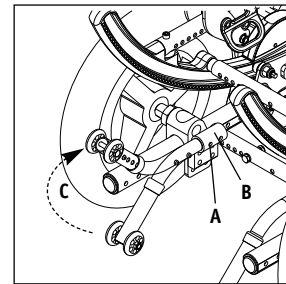

2. Turning Anti-Tip Tubes Up

Turn anti-tip tubes up when being pushed by attendant, overcoming obstacles or climbing curbs.

- Press the rear anti-tip tube release pin (A).
- Hold pin in and turn anti-tip tube up (C).
- Release pin.
- Repeat with second anti-tip tube.
- Remember to return anti-tip tubes to down position after completing maneuver.

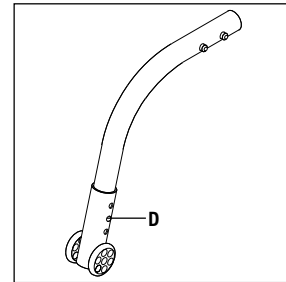

3. Adjusting Anti-Tip Tube Wheel

The anti-tip tube wheels may have to be raised or lowered to achieve proper ground clearance (1-1/2" to 2").

- Press the anti-tip wheel release pin (D) so that the release pin is drawn inside.
- Raise or lower to one of the three or four pre-drilled holes.
- Release pin (D).
- Adjust the second anti-tip tube wheel the same way. Both wheels should be at exactly the same height.

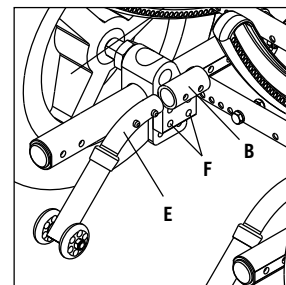

4. Height adjustment of the receivers

- Remove anti-tip tubes (E) from anti-tip receivers (B).
- Remove bolts (F) from anti-tip tube receiver.
- Reposition bracket to desired height. The receiver can be positioned up or down as needed.
- Reinsert bolts (F) and tighten.
- Repeat with second anti-tip tube receiver. Both brackets should be at exactly the same height.
- Replace anti-tip tubes.

K. ANTI-TIP TUBES- FRONT

NOTE– Use a torque setting of 100 in.-lbs. when setting-up anti-tip tubes.

1. Inserting Anti-Tip Tubes Into Receivers

- Press the front anti-tip release pin (A) on the anti-tip tube so that both release pins are drawn inside.
- Insert into the anti-tip tube receiver (B).
- Turn the anti-tip tube down until release pin is through the receiver mounting hole.
- Insert second anti-tip tube the same way.

2. Turning Anti-Tip Tubes Up

See Turning Anti-tip Tubes Up section J-2.

3. Adjusting Anti-Tip Tube Wheel

See adjusting Anti-Tip Tube Wheel section J-3.

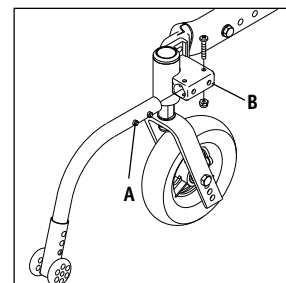

L. TILT-IN-SPACE MECHANISM

The tilt-in-space mechanism is installed by Sunrise. Two cable/trigger mechanisms positively lock the chair in place from -5° to 60° depending on the set-up. The Zippie IRIS has the capability to provide from 0° to 5° of forward tilt. DO NOT ATTEMPT TO MAKE THIS ADJUSTMENT. This adjustment must be done by an authorized supplier.

1. Tilt Operation

- Depressing both triggers (C) at the same time disengages the locking mechanism and allows the seat and back to rotate in space. Releasing the triggers positively locks the rockers in place.
- The approximate degree of tilt the seat is at can be seen on the tilt indicator (D).
- To lock out the tilting function, insert the locking pin (E) into the trigger holder.

2. Tilt-stops Adjustment

Adjustments can be made to limit the amount of tilt (rotation) that the chair provides by using the tilt-stops (A).

- Loosen and remove the retaining screw (B).
- Locate the tilt-stops to the desired limit either anterior or posterior.
- Each half of tilt stop assembly should plug into directly opposing holes on the rocker (C), then secure in place by tightening the screw (B).

3. Cable Adjustment

NOTE– Do not use lubricants on the components or assembly.

- Loosen and remove nuts (D) and remove bracket assembly (E).
- Loosen the jam nut (F).
- Rotate the cable adjuster (G) until slack is removed from the cable. Make sure the plunger pin can fully extend and retract after adjustment.
- Tighten jam nut (F).
- Reinstall the bracket assembly (E).
- Install and tighten nuts (D).

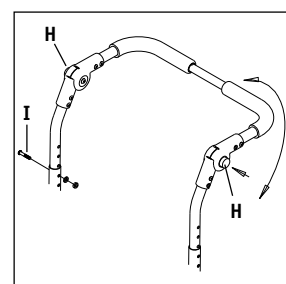
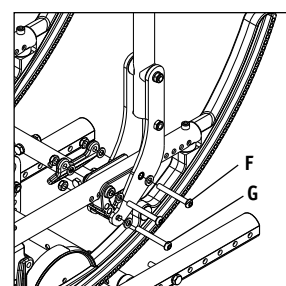
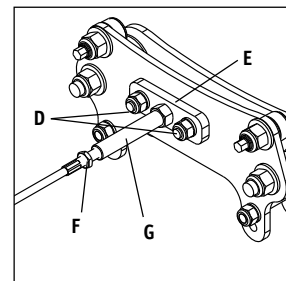
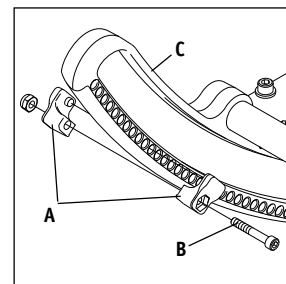
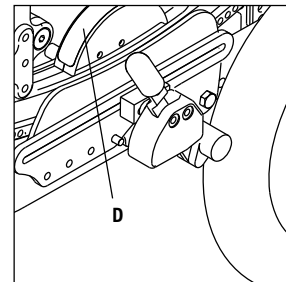
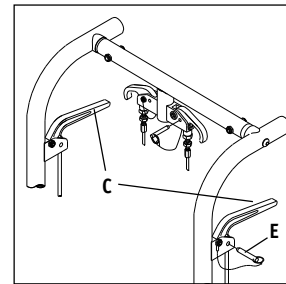

M. HEIGHT-ADJUSTABLE BACK WITH ADJUSTABLE STROLLER HANDLE (OPTIONAL)

1. Angle Adjustment

- Loosen rear bolt (F).
- Loosen and remove front bolt (G).
- Set backrest at desired angle using pre-set holes.
- Replace and tighten the front bolt (G).
- Tighten rear bolt (F).
- Repeat on other side.

IMPORTANT NOTE– The adjustment on each side of the chair should be exactly equal.

NOTE– Use a torque setting of 96 in.-lbs. when setting-up the angle adjustment of the stroller handle.

2. Angle Adjustment of the Stroller Handle

Depress both black push buttons (H) at the same time. This disengages the stroller handle and allows it to rotate freely. Releasing the push buttons positively locks the adjustable stroller handle in the desired position.

3. Height Adjustment

- Remove both bolts (I) from the backrest tube (one on each side).
- Reposition backrest height.
- Re-tighten both bolts (I) in the desired location.

4. Flip-Down Back Function

- To fold the back down, pull-up the back release pins (A) and push the backrest forward.
- To lock it back in position, lift the backrest firmly until it locks in its original position.

N. STROLLER HANDLE EXTENSION (OPTIONAL)

Installation

- Press button (B) on the stroller handle so that release pins are drawn inside the tube.
- Insert the tube into the back tube receiver (C) until the release pin protrudes through the receiver mounting hole.

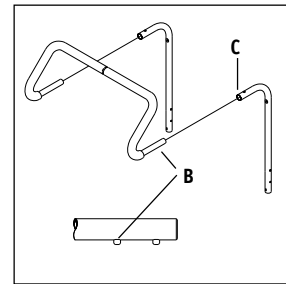
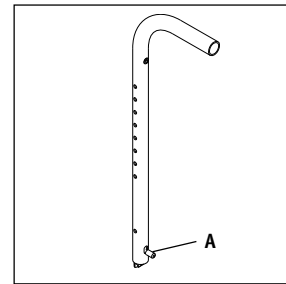

O. RECLINING BACK

The dual trigger reclining mechanism is installed by Sunrise.

1. To Recline or Raise Backrest

- Depress both triggers (D) at the same time. Releasing the triggers positively locks the backrest in place within its 45° range.
- To lock out the adjustment system, insert the locking pin (E) into the trigger holder. Always lock the dual trigger reclining mechanism securely in place after positioning the backrest.

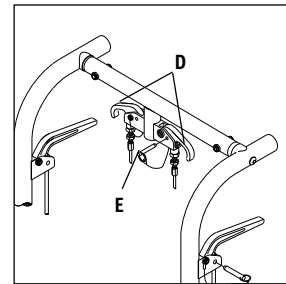

P. FRAME DEPTH

1. Back adjustment

- Loosen and remove the front bolt (F) located in front of back mounting plate.
- Loosen and remove the rear bolt (H) from the back mounting plate.
- Repeat both steps on the other side.
- Slide the backrest along the seat rail to the desired position.
- Replace and tighten the front bolt (F) and the rear bolt (H).
- Repeat on the other side.

IMPORTANT NOTE– The adjustment on each side of the chair should be exactly equal.

2. Hanger Receiver Adjustment

- Loosen and remove the socket head screws (A) from the seat rail.
- Slide the hanger receiver (B) in the seat rail to the desired position.
- Replace and tighten the socket head screws.
- Repeat on the other side.

IMPORTANT NOTE– These adjustments may also require re-positioning the carriage over the base frame, refer to matrix in the ordering guide for recommended location.

NOTE– Depending on the original position of the hanger receiver and the amount of adjustment required, a new set of seat tubes may be required. Holes in the hanger receiver should not be visible past the front of the seat tube.

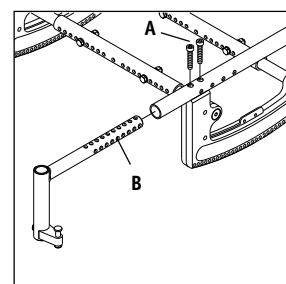
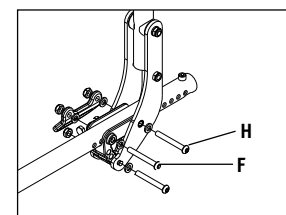
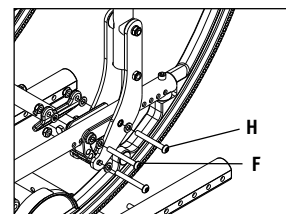

Q. FRAME WIDTH

The frame of the IRIS is built to accommodate growth from 10" to 18" wide using the three strut tube assemblies. Moving one hole position on each side of the strut provides a 1" frame width change.

1. Width Adjustment

- Remove the bolts (C) from one side of the strut tubes (D) for all strut tubes.
- Slide the adjustable extension (E) to the desired width according to the matrix in the ordering guide.
- Replace and tighten the bolts in all strut tubes.
- Repeat on the other side.

IMPORTANT NOTE– The adjustment on each side of the chair should be exactly equal and the alignment of the holes must remain horizontal.

NOTE– Use a torque setting of 96 in.-lbs. when setting up frame width.

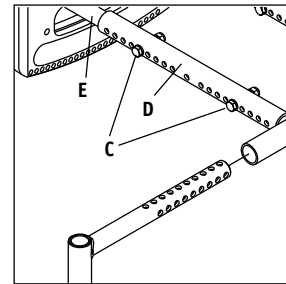

R. SEAT PAN

The seat pan of the IRIS is designed to accommodate depth adjustment.

Depth adjustment

- Loosen and remove all bolts (F).
- Adjust the seat pan to the desired depth.
- Replace and tighten all bolts.

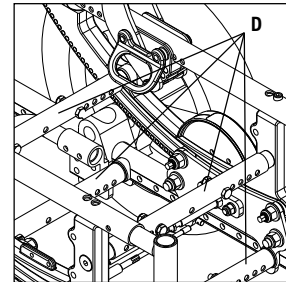

S. CUSHION INSTALLATION

- Place cushion on seat pan with hook material side down. The beveled edge of the cushion should be in front.
- Press firmly into place.

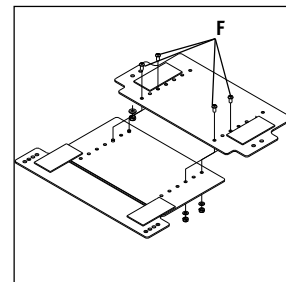

T. REAR AXLE

1. To Mount and Remove Rear Wheels (optional)

Do not use this chair UNLESS you are sure both quick-release axles are locked. An unlocked axle may come off during use and cause a fall.

NOTE– Axle is not locked until the quick-release button (A) pops out fully.

2. To Install Wheel

- Depress quick-release button (A) fully. This will release tension on ball bearings at other end.
- Insert axle through hub of rear wheel (B).
- Keep pressure on button (A) as you slide axle (C) into axle sleeve (D).
- Release button to lock axle in sleeve. Adjust axle if it does not lock.
- Repeat steps on other side.

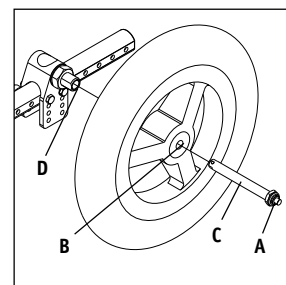

3. To Remove Wheel

- Depress quick-release button (A) fully.
- Remove wheel by sliding axle (C) out of axle sleeve (D).
- Repeat steps on other side.

4. Rear Wheel Axle Adjustment

Tight axle sleeves should be maintained for proper performance of the wheelchair.

- To adjust the axle you will need a 3/4" wrench to turn the outside axle nuts.
- You will also need a 1/2" wrench (E) to lodge the ball bearings (F), on the opposite end of the axle, and prevent the axle from turning.
- Turn the outside axle nut counter-clockwise to tighten.
- There should only be zero to ten thousandths of an inch (.010) of play.

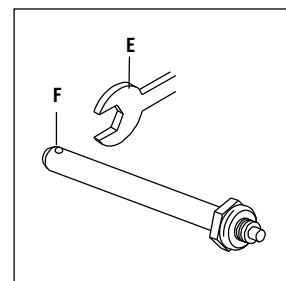

5. Weight Distribution

Weight distribution between the front and rear wheels is primarily adjusted by moving the rear axles forward or rearward on the frame.

Moving the axles REARWARD provides better forward and rearward tipping stability.

Moving the axles FORWARD shifts more of the rider's weight onto the REAR wheels, providing the following benefits: the front end of the wheelchair becomes lighter, thus reducing the turning effort, and with a shorter wheelbase the turning radius is reduced.

6. Axle Adjustment

- Remove both wheels from the chair.
- Remove the bolts (A) from the axle plate (B).
- Reposition the axle plate in desired position.
- Insert and tighten bolts (A).
- Repeat on the other side.

IMPORTANT NOTE– The adjustment on each side of the chair should be exactly equal.

IMPORTANT NOTE– Do not attempt to make this adjustment. This adjustment must be done by an authorized supplier only.

NOTE– Use a torque setting of 96 in.-lbs. when setting-up the axle plate.

7. Axle Height Adjustment

- Loosen and remove bolts (A).
- Set axle at desired height using pre-set holes in the axle plate (B).
- Replace and tighten bolts.
- Repeat on other side.

IMPORTANT NOTE– The adjustment on each side of the chair should be exactly equal.

IMPORTANT NOTE– Do not attempt to make this adjustment. This adjustment must be done by an authorized supplier only.

NOTE– Use a torque setting of 96 in.-lbs. when setting-up the axle plate.

NOTE– The frame must be kept horizontal when height adjustments are made. Refer to matrix in the ordering guide for proper setting.

U. CARRIAGE

The carriage of the Zippie IRIS can be adjusted to preset the range of tilt from -5° to 50° from 0° to 55° or from 5° to 60° .

IMPORTANT NOTE– Do not attempt to make this adjustment. This adjustment must be done by an authorized supplier only.

1. Adjustment

- Loosen and remove front bolt (A) and rear bolt (B) from the carriage on each side.
- Set the carriage at desired range according to range settings below.
- Replace and tighten all bolts.

IMPORTANT NOTE– The adjustment on each side of the chair should be exactly equal.

NOTE– Use a torque setting of 96 in.-lbs. when setting-up carriage.

2. Range and setting

- Figure C: -5° to 50°
- Figure D: 0° to 55°
- Figure E: 5° to 60°

3. Top Roller Adjustment

Tools recommended: (1) $1/4$ " open-end wrench and (1) $9/16$ " open-end wrench.

IMPORTANT NOTE– Remove the rider from the chair before performing this maintenance.

NOTE– It is highly recommended to adjust all 4 of the top rollers at the same time.

- Loosen the cam nut (F).
- Use a $1/4$ " wrench to rotate the eccentric cam bolt (G) clockwise until the top roller (H) just makes contact with the rocker (I).
- While holding the $1/4$ " wrench, tighten the $9/16$ " nut (F) to approximately 120 in.-lbs of torque to lock the assembly into place. Although the top roller should be touching the rocker, there should be NO CONTACT PRESSURE of the top roller against the rocker when the assembly is in the tightened condition. The top roller should be able to rotate by applying mild finger pressure.

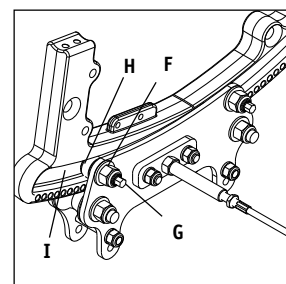
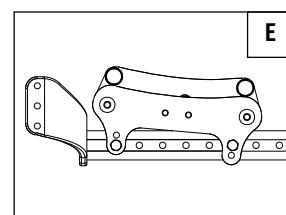
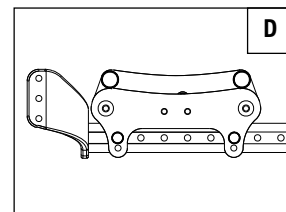
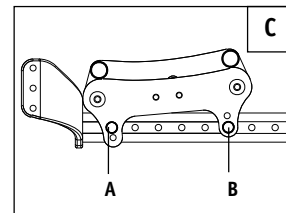
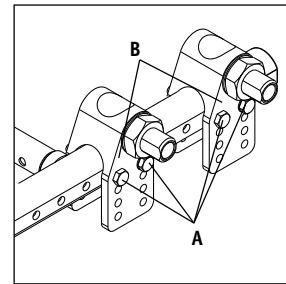

4. Top Roller Replacement

NOTE– It is highly recommended to replace both top rollers within each carriage assembly at the same time. Do not use lubricants anywhere on the assembly.

- Loosen both plunger pin bracket nuts (J).
- Loosen and remove both bottom roller nuts (K) and both chassis fastener nuts (L).
- Slide the inner carriage plate (M) off the fasteners, towards the center of the chair.
- Loosen and remove both eccentric cam nuts (N).
- Remove old top rollers (O) from the eccentric cam bolts (P) and replace with new top rollers.
- Reinstall the eccentric cam bolts (P) onto the inner carriage plate (M), installing nuts (N) only finger tight.
- Reinstall the carriage plate (M) onto the frame assembly (Q). Replace and tighten the nuts (K, L).
- Ensure that the plunger pin is centered and engaged into a rocker hole and tighten plunger pin bracket nuts (J).
- Adjust the top roller assemblies per number 3: Top Roller Adjustment.
- Repeat on the other side of chair as necessary.

NOTE– Use a torque setting of 120 in.-lbs. when setting up top roller.

5. Bottom Roller Replacement

NOTE– It is highly recommended to replace both bottom rollers within each carriage assembly at the same time. Do not use lubricants anywhere on the assembly.

- Loosen both plunger pin bracket nuts (J).
- Loosen both eccentric cam nuts (N).
- Loosen and remove both bottom roller nuts (K) and both chassis fastener nuts (L).
- Slide the inner carriage plate (M) off the fasteners, towards the center of the chair.
- Remove old bottom rollers (R) from the roller bushings (S) and replace with new bottom rollers.
- Reinstall the carriage plate (M) onto the frame assembly (Q). Replace and tighten the nuts (K, L).
- Ensure that the plunger pin is centered and engaged into a rocker hole and tighten plunger pin bracket nuts (J).
- Adjust the top roller assemblies per number 3: Top Roller Adjustment.
- Repeat on the other side of chair as necessary.

NOTE– Use a torque setting of 180 in.-lbs. when tightening bottom roller nuts (K).

V. WHEEL LOCKS

Zippie IRIS wheelchairs are standard with wheel locks. Wheel locks are installed at Sunrise.

Adjustment

- Loosen the screws (F). Do not attempt to remove one screw at a time.
- Slide assembly toward rear wheel until clamp embeds into tire to prevent wheel movement, when in locked position.
- Tighten screws.

W. HUB LOCK INSTALLATION

- Remove wheel and axle from chair.
- Remove 1/4" x 2" long bolts from axle plate (item 20). Note position and orientation of the axle plate.
- Remove 3/4" Nut (item 17) and washer (item 18) from axle sleeve (item 19).
- Place Hub Lock Axle Plate Adapter (item 14) against axle plate and attach axle plate and adapter to frame using bolts supplied (item 13 or 13A). If anti-tips are to be installed, the bolts will be 1/4" x 2-3/4" long. If no anti-tips are used the bolts will be 1/4" x 2-1/4" long. Secure new bolts using washers along with new 1/4" lock nuts as shown.
- Thread axle sleeve further into axle plate such that when the 3/4" nut is tightened, the face of the axle sleeve protrudes out of the 3/4" Nut by approximately 1/32". Tighten 3/4" Nut.
- Discard the large inner diameter spacer and 1/4" x 3" bolt provided with the Lower Hub Lock Assembly (item 11). Place nose of Hub Lock Axle Spacer into hole in Lower

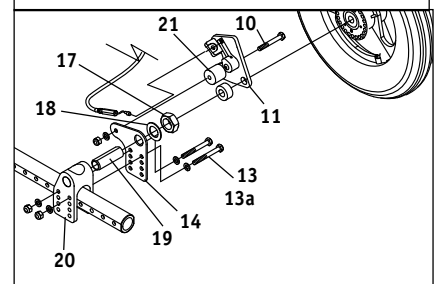
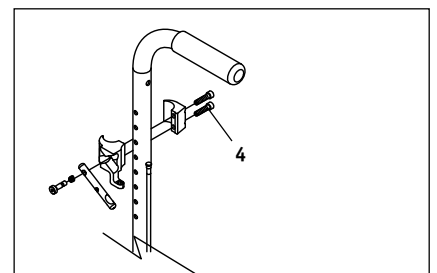
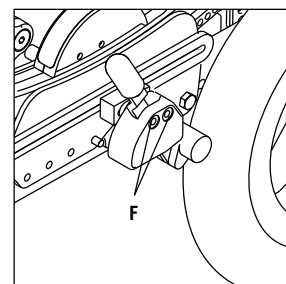
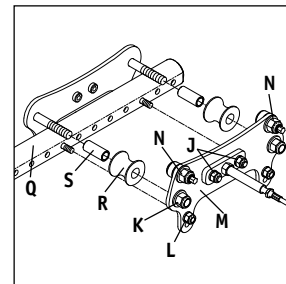
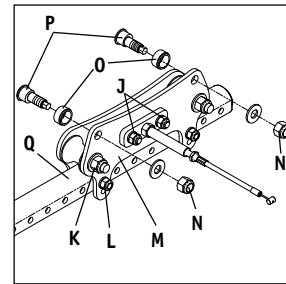

Hub Lock Installation

Hub Lock Assembly and hold in place over 3/4" nut. Place 1/4" spacer (item 21) between the Lower Hub Lock Assembly plate and the Hub Lock Axle Plate Adapter, aligning holes. Slide 1/4" x 1-3/4" bolt (item 10) through plate of Lower Hub Lock Assembly, 1/4" spacer (item 21) and Axle Plate Adapter (item 14). Attach nut provided with washer to 1/4" bolt as shown and tighten.

7. Remove 2 screws (item 4) from clamp assembly. Wrap clamps around push handle back tube, reinsert screws, and leave them loose. Slide to desired position and tighten securely.
8. Attach new wheel and axle through axle sleeve.
9. Repeat steps 1-8 on opposite side.

X. ATTENDANT WHEEL LOCK INSTALLATION

1. Remove wheels from chair.
2. Attach Mount bracket/cable assembly to rear base strut tube using 1/4" x 1-3/4" bolt (item 14) with nut and washers, being sure to go through spacer tube (item 13) provided as shown.
3. If push-to-lock wheel locks are already installed, remove the push-to-lock assemblies by removing the M6 bolts (item 6) and adjustment nuts (item 9), leaving the slide plates mounted on the chair, and go to step 5. If there are no wheel locks mounted already, proceed with step 4.
4. Attach Wheel Lock Slide Plates to Roller Assembly on each side of the chair using 1/4" x 1-1/4" bolts (item 10) and Mounting Block (item 8). If axle of rear wheel is above the base frame tube, orient the slide plates upward. If the axle of the rear wheel is below the base frame tube, orient the plates downward.
5. Attach the left and right Remote Lock Assemblies (item 4) to the slide plates using the Attendant Wheel Lock Spacer Blocks (item 3), M6 x 60 screws (item 6), lock washers (item 5), and Wheel Lock Adjustment Nuts (item 9). (If dual post armrests are installed, you may need to use the additional spacer block (item 2) and M6 x 70 bolts). The adjustment nuts marked "R" and "L" are to be mounted to the right and left side of the chair respectively. The smaller protruding oval shape on the nuts should slide inside of the slot in the slide plate. Do not tighten bolts. Slide the Remote Lock Assemblies as far forward as they will go.
6. Re-install wheels and slide the Remote Lock Assemblies rearward until the friction block of the remote lock is approximately 1/4" away from the tire when unlocked. If the lock cannot be adjusted to this position, you will need to adjust the position of the slide plate until it can be adjusted as stated. Once remote locks are properly positioned, tighten bolts.
7. Attach cables to Remote Lock Assemblies by sliding the stud at the end of the cable into the slot in the Remote Lock Assembly. Pull back on the cable sheath and slide the end of the cable sheath into the pocket on the Attendant Wheel Lock Spacer Block (item 3) as shown. Be sure that the cables are routed away from all moving parts. Attach the cables into place on the chair with zip-ties provided.
8. Adjust the cable adjustment screws (item 24) as necessary to ensure that the wheel locks can get to their fully extended position when the pedal is engaged. Position of the Remote Lock Assembly may need to be fine tuned to optimize the force needed to engage the pedal, depending on tire type. If excessive force is needed to engage the pedal, cable life may be reduced. Once proper adjustment is attained, lock cable adjustment screw in position by tightening jam nuts against mounting block.

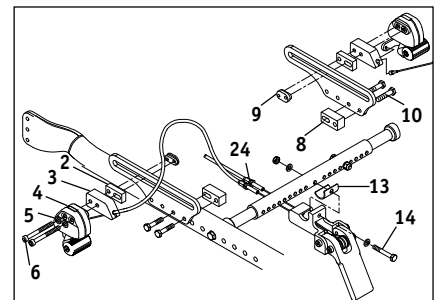

Attendant Wheel Lock Installation

Y. CHECK-OUT

Once the wheelchair is assembled and adjusted, it should roll smoothly and easily. All accessories should also perform smoothly. If you have any problems, follow these procedures:

1. Review assembly and adjustment sections to make sure the chair was properly prepared.
2. Review troubleshooting guide.
3. If your problem persists, contact your authorized supplier. If you still have a problem after contacting your authorized supplier, contact Sunrise customer service. See the introduction page for details on how to contact your authorized supplier or Sunrise customer service.

(FIGURES A & B)-PAGE 33

⚠ WARNING

Read the User's Manual before installing the battery tray components onto the wheelchair.

⚠ WARNING

Never use this wheelchair as a seat in a motor vehicle unless all components are removed from the battery tray, and properly secured separately in the vehicle.

⚠ WARNING

Always contact Technical Service before installing or removing the battery tray components to obtain the correct assembly locations of the strut tubes, roller carriage assembly and caster brackets.

⚠ WARNING

Do not install the battery tray components onto wheelchairs when the user weighs more than 150lbs.

NOTE – This option is only compatible with wheelchairs having a minimum floor-to-seat height of 15".

NOTE – The battery tray components are not compatible with the Attendant Wheel Lock option.

A. HOW TO MAKE WHEELCHAIR WIDTH ADJUSTMENTS

NOTE – The (2) strut tubes supplied with the battery tray kit create one unique wheelchair width. Please contact Sunrise Medical to acquire strut tubes for other wheelchair widths.

1. Loosen and remove the bolts (A) from both ends of the two battery tray strut tube mounts (G)
2. Loosen bolts from both ends of the front strut tube.
3. Remove the battery tray.
4. Adjust the width of the chair.
5. Loosen and remove nuts and bolts (D) from the battery tray mounting brackets (E) on both strut tubes (F).
6. Remove Bolts and nuts (B) and replace the old battery tray strut tubes with the required size to match the desired width of the chair.
7. Insert the strut tubes (F) back into the battery tray mounting brackets (E), replacing bolts and nuts (D).
8. Fasten strut tube mounts (G) onto new battery tray strut tubes, replace and tighten the bolts (B). Heads of bolts should be on top.
9. Put the battery tray with the strut tubes back into place, replace and tighten bolts (A) into both ends of all strut tubes.

NOTE – Use a torque setting of 96 in-lb when tightening struts, carriages and axle plates.

B. HOW TO ADD THE BATTERY TRAY KIT

1. Loosen and remove the bolts (A) from the rear strut tube. The existing rear strut tube will not be used in the battery tray setup.
2. Relocation of carriage (when needed, consult customer service)
 - a. Loosen and remove rear bolt (i) from the carriage on each side.
 - b. Loosen and remove front bolt (ii) from the carriage on each side.
 - c. Set the carriage at desired location
 - d. Replace and tighten bolts
3. Relocation of Axle Plates (when needed, consult customer service)
 - a. Loosen and remove front and rear bolts from the axle plate on each side, noting the orientation and holes used on the axle plate.
 - b. Set the axle plate at new location
 - c. Replace and tighten bolts. Be sure to use the same orientation and holes in the axle plate as were being used previously, unless a seat height adjustment is being made.
4. Loosen bolts from both ends of the front strut tube.
5. Place Battery Tray with new middle and rear battery tray struts in proper locations (consult customer service for proper locations).
6. Replace and tighten bolts (A) into front strut tube and middle and rear strut tube mounts (G).

NOTE – Use a torque setting of 96 in-lb when tightening struts, carriages and axle plates.

C. HOW TO REMOVE BATTERY TRAY COMPONENTS

WARNING

Always contact Technical Service before installing or removing the battery tray components to obtain the correct assembly locations of the strut tubes, roller carriage assembly and caster brackets.

1. Loosen and remove the bolts (A) from the middle and rear Battery Tray Strut Tubes. Relocation of carriage (when needed, consult customer service)
 - a. Loosen and remove rear bolt (i) from the carriage on each side. Loosen and remove front bolt (ii) from the carriage on each side.
 - c. Set the carriage at desired location
 - d. Replace and tighten bolts
3. Relocation of Axle Plates (when needed, consult customer service)
 - a. Loosen and remove front and rear bolts from the axle plate on each side, noting the orientation and holes used on the axle plate.
 - b. Set the axle plate at new location
 - c. Replace and tighten bolts. Be sure to use the same orientation and holes in the axle plate as were being used previously, unless a seat height adjustment is being made.
4. Install Base Frame Strut (standard strut, not battery tray strut) into proper position (consult customer service for proper rear strut size and position), and tighten all strut bolts (A).

NOTE – Use a torque setting of 96 in-lb when tightening struts, carriages and axle plates.

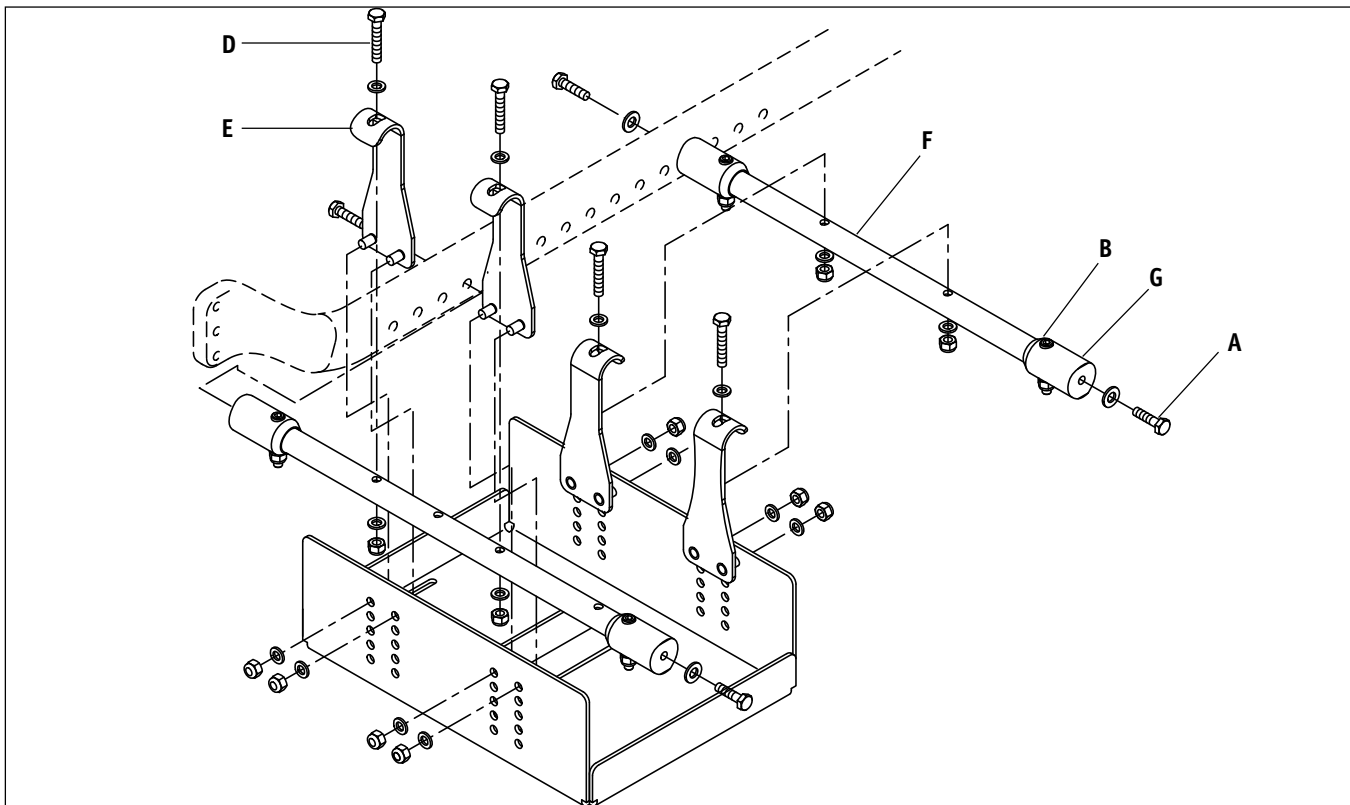

Battery Tray
Figure A

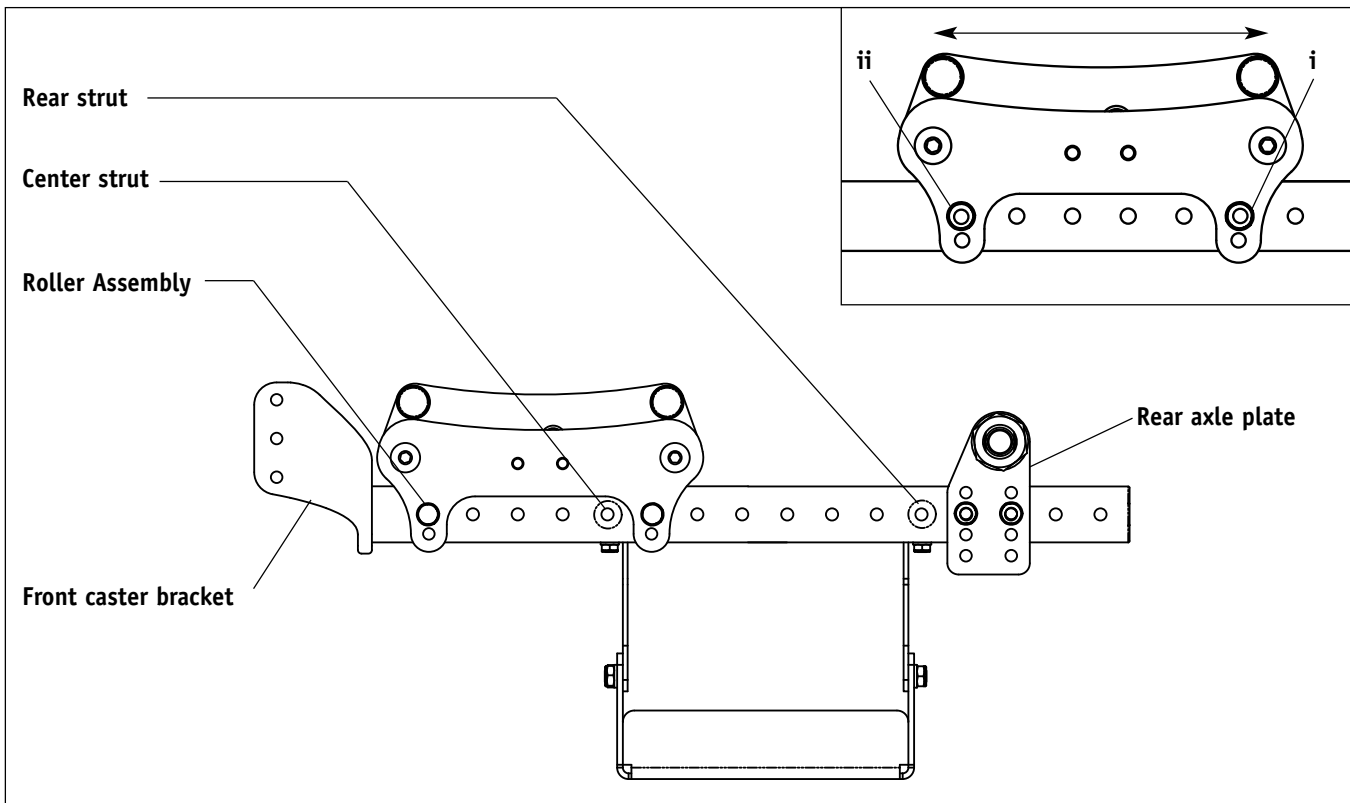

Battery Tray
Figure B

You will need to adjust your chair from time to time for best performance (especially if you alter the original settings). This chart gives you a first solution, then a second and a third if needed. You may need to look farther to find the best solution for a specific problem.

NOTE– To keep track of your progress, make only ONE change at a time.

SYMPTOMS	SOLUTIONS					
	Left turn in chair	Right turn in chair	Looseness in chair	Sluggish turning	Squeaks and rattles	Caster flutter
✓	✓	✓	✓			Make sure tire pressure is correct and equal in both rear tires and front caster tires, if pneumatic.
		✓	✓	✓	✓	Make sure all nuts and bolts are snug.
		✓		✓		Make sure all spokes and nipples are tight on radial spoke wheels.
				✓		Use Tri-Flow Lubricant (Teflon™-based) between all modular frame connections and parts.
✓	✓		✓		✓	Check for proper caster plate adjustment. See instructions for caster plate adjustment.
	✓					Add a spacer washer between the plastic saddle and the caster plate on the top of the left caster plate.
✓						Add a spacer washer between the plastic saddle and the caster plate on the top of the right caster plate.
✓						Add a spacer washer between the plastic saddle and the caster plate on the bottom right caster plate retaining bolts.
	✓					Add a spacer washer between the plastic saddle and the caster plate on the bottom left caster plate retaining bolts.
✓	✓				✓	Make sure both front casters touch the ground simultaneously. If they do not, add the proper spacers between the bottom bearing of the caster plate and fork stem nut until they do. Make sure you check for this problem on a flat surface.

A. INTRODUCTION

1. Proper maintenance will improve performance and extend the useful life of your chair.
2. Clean your chair regularly. This will help you find loose or worn parts and make your chair easier to use.
3. Repair or replace loose, worn, bent or damaged parts **before using this chair**.
4. To protect your investment, have all major maintenance and repair work done by your authorized supplier.

⚠ WARNING

If you fail to heed these warnings your chair may fail and cause severe injury to the rider or others.

1. **Inspect and maintain this chair strictly per maintenance chart.**
2. **If you detect a problem, make sure to service or repair the chair before use.**
3. **At least once a year, have a complete inspection, safety check and service of your chair made by an authorized supplier.**

B. MAINTENANCE CHART

Weekly	3 Months	6 Months	Annually	CHECK...
✓				Tire inflation level
✓				Wheel locks
	✓			All fasteners for wear and tightness
		✓		Armrests
		✓		Axle and axle sleeves
	✓			Quick-release axles
	✓			Wheels, tires and spokes
	✓			Casters
	✓			Anti-tip tubes
		✓		Frame
✓				Rollers
✓				Tilt cables and plunger
✓				Rocker arm
			✓	Service by authorized supplier

C. MAINTENANCE TIPS

1. Axles & Axle Sleeves:

Check axles and axle sleeves every six months to make sure they are tight. Loose sleeves will damage the axle plate and will affect performance.

2. Tire Air Pressure:

Check air pressure in pneumatic tires at least ONCE A WEEK. The wheel locks will not grip properly if you fail to maintain the air pressure shown on tire sidewall.

D. CLEANING

1. Paint Finish

- a. Clean the painted surfaces with mild soap at least once a month.
- b. Protect the paint with a coat of non-abrasive auto wax every three months.

2. Axles and Moving Parts

- a. Clean around axles and moving parts WEEKLY with a slightly damp (not wet) cloth.
- b. Wipe off or blow away any fluff, dust or dirt on axles or moving parts.

NOTE– You do not need to grease or oil the chair.

3. Rocker arm and Carriage Assembly

- a. Wipe the rocker arm's lower convex surface WEEKLY with a slightly damp (not wet) cloth.
- b. Check the plunger on each side weekly, dismantle and clean if needed. See Section (L) (3) Cable Adjustment.

E. STORAGE TIPS

1. Store your chair in a clean, dry area. If you fail to do so, parts may rust or corrode.
2. Before using your chair, make sure it is in proper working order. Inspect and service all items on the "Maintenance Chart".
3. If stored for more than three months, have your chair inspected by an authorized supplier before use.

A. FOR LIFETIME

Sunrise warrants the frame of this wheelchair against defects in materials and workmanship for the life of the original purchaser.

The expected life of this frame is five years.

B. FOR ONE (1) YEAR

We warrant all Sunrise-made parts and components of this wheelchair against defects in materials and workmanship for one year from the date of first consumer purchase.

C. LIMITATIONS

1. We do not warrant:
 - Tires and tubes, upholstery, armrests and push-handle grips.
 - Damage from neglect, misuse or from improper installation or repair.
 - Damage from exceeding weight limit of 150 pounds.
2. This warranty is VOID if the original chair serial number tag is removed or altered.
3. This warranty applies in the USA only. Check with your supplier to find out if international warranties apply.

D. WHAT WE WILL DO

Our sole liability is to repair or replace covered parts. This is the exclusive remedy for consequential damages.

E. WHAT YOU MUST DO

1. Obtain from us, while this warranty is in effect, prior approval for return or repair of covered parts.
2. Return the wheelchair or part(s), freight pre-paid, to Sunrise Mobility Products Division at: 2842 Business Park Avenue, Fresno, CA 93727-1328.
3. Pay the cost of labor to repair, remove or install parts.

F. NOTICE TO CONSUMER

1. If allowed by law, this warranty is in place of any other warranty (written or oral, expressed or implied, including a warranty of merchantability, or fitness for a particular purpose).
2. This warranty gives you certain legal rights. You may also have other rights that vary from state to state.

Record your serial number here for future reference:
