

TOP END[®]
Crossfire[™] ***T6A Wheelchair***



DEALER: This manual **MUST** be given to the user of the wheelchair.

USER: **BEFORE** using this wheelchair, read this manual and save for future reference.

For more information regarding
Invacare products, parts, and services,
please visit www.invacare.com



Yes, you can.

⚠ WARNING

DO NOT USE THIS PRODUCT OR ANY AVAILABLE OPTIONAL EQUIPMENT WITHOUT FIRST COMPLETELY READING AND UNDERSTANDING THESE INSTRUCTIONS AND ANY ADDITIONAL INSTRUCTIONAL MATERIAL SUCH AS OWNER'S MANUALS, SERVICE MANUALS OR INSTRUCTION SHEETS SUPPLIED WITH THIS PRODUCT OR OPTIONAL EQUIPMENT. IF YOU ARE UNABLE TO UNDERSTAND THE WARNINGS, CAUTIONS OR INSTRUCTIONS, CONTACT A HEALTHCARE PROFESSIONAL, DEALER OR TECHNICAL PERSONNEL BEFORE ATTEMPTING TO USE THIS EQUIPMENT - OTHERWISE, INJURY OR DAMAGE MAY OCCUR.

⚠ ACCESSORIES WARNING

Invacare products are specifically designed and manufactured for use in conjunction with Invacare accessories. Accessories designed by other manufacturers have not been tested by Invacare and are not recommended for use with Invacare products.

NOTE: Updated versions of this manual are available on www.invacare.com.

TABLE OF CONTENTS

REGISTER YOUR PRODUCT	6
SPECIAL NOTES	7
TYPICAL PRODUCT PARAMETERS	8
SECTION I—GENERAL GUIDELINES	10
Stability Warning.....	10
Operating Information.....	11
Tire Pressure and Information	12
Weight Training	12
Weight Limitation.....	12
SECTION 2—SAFE HANDLING	13
Stability and Balance.....	13
Coping with Everyday Obstacles.....	14
A Note to Wheelchair Assistants.....	15
Reaching, Leaning and Bending - Forward.....	15
Reaching, Leaning - Backwards	15
Tipping.....	16
Tipping - Curbs	16
Stairways.....	17
Transferring To and From Other Seats	18
SECTION 3—SAFETY INSPECTION	19
Safety Inspection Checklist.....	19
Inspect Initially	19
Inspect/Adjust Weekly.....	20
Inspect/Adjust Monthly.....	20
Inspect/Adjust Periodically.....	21
Troubleshooting.....	21
Maintenance	22
Maintenance Safety Precautions	22
Suggested Maintenance Procedures	22
SECTION 4—FOOTREST	24
Adjusting/Replacing Standard Footrest.....	24
Replacing the Footrest.....	24
Adjusting the Footrest.....	24
Replacing/Adjusting Optional Adjustable Angle Footrest	25
Replacing the Footrest.....	25
Adjusting Footplate Angle.....	25
Adjusting Footplate Depth.....	25

TABLE OF CONTENTS

SECTION 5—ARMS	27
Installing the Swingaway Padded Armrest Socket.....	27
Adjusting Swingaway Padded Armrest Height.....	29
Removing/Installing and Adjusting T-Arms.....	30
Removing/Installing T-Arms.....	30
Adjusting T-Arm Height.....	30
Adjusting T-Arm Position	30
SECTION 6—BACK	31
Unfolding/Folding the Back.....	31
Back Angle Adjustment.....	32
Adjustable Tension Back Upholstery.....	34
The Back Upholstery Cover.....	34
Adjusting the Tautness of the Back.....	34
Removing/Installing the Back Upholstery Cover, Adjustable Tension Back Upholstery and Lumbar Strap	35
Removing/Installing Foldover Back Upholstery	37
Removing Foldover Back Upholstery.....	37
Installing Foldover Back Upholstery.....	37
Back Height Adjustment	38
SECTION 7—SEAT	39
Replacing Seat Upholstery.....	39
Seat Angle Adjustment.....	40
SECTION 8—WHEEL LOCKS	42
Replacing/Adjusting the Wheel Locks	42
Replacing the Wheel Lock.....	42
Adjusting the Wheel Lock.....	42
Changing Wheel Lock Handle Position.....	43
Converting Wheel Lock From Push-to-Lock to Pull-to-Lock or Pull-to-Lock to Push-to-Lock.....	44
Converting From Push-to-Lock to Pull-to-Lock.....	44
Converting From Pull-to-Lock to Push-to-Lock.....	44
SECTION 9—WHEELS	45
Removing/Installing Rear Wheels	45
Adjusting Quick-Release Axles.....	46
Replacing Quad-Release Axles.....	46
Adjusting Quad-Release Handles.....	47
In and/or Out.....	47

TABLE OF CONTENTS

Removing Play from Rear Wheels	47
Handrim Replacement.....	48
Repairing/Replacing Rear Wheel, Tire/Tube.....	49
Adjusting Wheelbase Length, Adjusting Center of Gravity (COG)	49
Repositioning the Camber Tube Clamps	51
Repositioning the Camber Tube Clamp Socket Screws.....	51
Reversing the Camber Tube Clamp Direction	52
Adjusting Wheelbase Width	53
Removing/Installing the Camber Tube.....	54
Removing the Camber Tube	54
Installing the Camber Tube	54
Adjusting the Camber Tube.....	55
Determining/Setting Toe In/Toe Out	56
Adjusting Fork Tension	57
Removing/Installing/Repositioning the Caster Assemblies.....	58
Standard Forks.....	58
Suspension Forks.....	58
Removing/Installing the Fork Assembly.....	59
Removing Fork Assembly.....	59
Installing Fork Assembly.....	60
Removing/Installing the Elastomers (Suspension Forks Only).....	61
Removing the Elastomer	61
Installing the Elastomer.....	61
SECTION 10—ANTI-TIPPER	62
Adjusting/Replacing Anti-tipper.....	62
Adjusting Anti-tipper.....	62
Replacing Anti-tipper.....	63
LIMITED WARRANTY	67

REGISTER YOUR PRODUCT

The benefits of registering include:

1. Safeguarding your investment.
2. Ensuring long-term maintenance and servicing of your product.
3. Receiving updates with product information, maintenance tips and industry news.

Register ONLINE at warranty.invacare.com

Please have your model number and purchase date available to complete your registration.

Any registration information you submit will only be used by Invacare Corporation and protected as required by applicable laws and regulations.

SPECIAL NOTES

Signal words are used in this manual and apply to hazards or unsafe practices which could result in personal injury or property damage. Refer to the table below for definitions of the signal words.

SIGNAL WORD	MEANING
DANGER	Danger indicates an imminently hazardous situation which, if not avoided, will result in death or serious injury.
WARNING	Warning indicates a potentially hazardous situation which, if not avoided, could result in death or serious injury.
CAUTION	Caution indicates a potentially hazardous situation which, if not avoided, may result in property damage or minor injury or both.

NOTICE

THE INFORMATION CONTAINED IN THIS DOCUMENT IS SUBJECT TO CHANGE WITHOUT NOTICE.

As a manufacturer of wheelchairs, Invacare endeavors to supply a wide variety of wheelchairs to meet many needs of the end user. However, final selection of the type of wheelchair to be used by an individual rests solely with the user and his/her healthcare professional capable of making such a selection.

WHEELCHAIR TIE-DOWN RESTRAINTS AND SEAT POSITIONING STRAPS

Invacare recommends that wheelchair users not be transported in vehicles of any kind while in wheelchairs. As of this date, the Department of Transportation has not approved any tie-down systems for transportation of a user while in a wheelchair, in a moving vehicle of any type.

It is Invacare's position that users of wheelchairs should be transferred into appropriate seating in vehicles for transportation and use be made of the restraints made available by the auto industry. Invacare cannot and does not recommend any wheelchair transportation systems.

⚠ WARNING

ALWAYS wear your seat positioning strap. Inasmuch as the seat positioning strap is an option on this wheelchair (you may order with or without the seat positioning strap), Invacare strongly recommends ordering the seat positioning strap as an additional safeguard for the wheelchair user. The seat positioning strap is a positioning belt only. It is not designed for use as a safety device withstanding high stress loads such as auto or aircraft safety belts. If signs of wear appear, belt **MUST** be replaced **IMMEDIATELY**.

With regards to seat/chest positioning straps - it is the obligation of the DME dealer, therapists and other healthcare professionals to determine if a seat/chest positioning strap is required to ensure the safe operation of this equipment by the user. Serious injury can occur in the event of a fall from a wheelchair.

TYPICAL PRODUCT PARAMETERS

NOTE: All specifications are approximate.

	CROSSFIRE T6A
FRONT FRAME:	Tapered front end (Standard), V-Style (Optional)
FRONT FRAME ANGLE:	70°, 75°, 80°, 85°
FOOTREST:	Tubular footrest in same material as frame (Standard), Adjustable Angle NCO, Plastic or Carbon Fiber Cover (Optional)
SEAT HEIGHT FRONT: REAR:	16 to 21 inches in $\frac{1}{2}$ inch increments (Fixed) 14 to 20 Inches (adjustable)
ARMS (OPTIONAL):	Swing-away Padded, T-arm
SIDE GUARDS (OPTIONAL) FOLDING BACK: FIXED BACK:	Removable, Removable with Fender Fixed Aluminum, Fixed Carbon Fiber, Fold In
SEAT WIDTH:	12 to 19 inches (Standard), 20 inches (Optional),
SEAT DEPTH:	14 to 19 inches (Standard), 20 inches (Optional)
BACK STYLE:	Lock Down, Folding (Standard)
BACK HEIGHT	8 to 11, 10 to 14, 12 to 16, 14 to 18, or 16 to 20 inches
BACK ANGLE FOLDING:	-8°, -4°, 0°, +4°, +8°
BACK UPHOLSTERY:	U850 (Ballistic Black) - Adjustable Tension by Straps Breathable Mesh (Black) Adjustable Tension by Straps Foldover
SEAT UPHOLSTERY:	Sail Cloth - Screw-On
AXLE POSITIONS/CENTER OF GRAVITY:	Range of Adjustability in both positions: Active Position: $\frac{3}{4}$ to 4 inches Amputee Position: $-1\frac{5}{8}$ to $1\frac{5}{8}$ inches
REAR WHEEL AXLE:	Quick Release (Standard), Quad-Release or Titanium (Optional)
REAR WHEEL CAMBER CAMBER TUBE:	0°, 3°, 6°, or 9°
REAR WHEELS REAR WHEEL TYPE: REAR WHEEL SIZE:	High Performance Spoke with Primo Tires (Standard), Spinergy® Spox, knobby, solid, Schwalbe® and Kenda Tires (Optional $1\frac{3}{8}$ pneu- matic, Pneumatic with flat free insert) 22, 24 or 25-inch (Standard), 26-inch (Optional)
HANDRIMS:	Aluminum Anodized (Standard) Titanium, Coated, Natural Fit® (Optional)
WHEEL LOCKS:	Pull/Push to Lock (Standard) or Scissor lock, Hill Holders (Optional)
FRONT FORKS:	Non-Suspension (Standard), Suspension (Optional)
CASTERS CASTER SIZE: CASTER TYPE:	3, 4 or 5-inch Semi-pneumatic (Standard), Soft Roll or Lighted (Optional)

TYPICAL PRODUCT PARAMETERS

	CROSSFIRE T6A
ANTI-TIPPERS:	Optional
WEIGHT:	22.4 lbs
SHIPPING WEIGHT:	33 lbs
WEIGHT LIMITATION:	250 lbs

NOTE: 16x16 w/ 24" Spinergy wheels, bolt-on seat upholstery, mesh back upholstery w/ adjustable tension & 4" semi-pneumatic casters are included in the weight.

SECTION I—GENERAL GUIDELINES

⚠ WARNING

SECTION I - GENERAL GUIDELINES contains important information for the safe operation and use of this product.

Stability Warning

The position of the footrest, camber tube (COG - Center of Gravity), seat angle, back angle, the tautness of the back upholstery as well as the user's condition are directly related to the wheelchairs stability. Any change to one or any combination of the six may cause the wheelchair to decrease in stability. Use EXTREME caution when using a new seating position. The addition of anti-tippers may be required.

	FOOTREST POSITION	CAMBER TUBE (COG)	BACK ANGLE	BACK UPHOLSTERY	USER CONDITION	SEAT ANGLE
FOOTREST POSITION	●		✓		✓	✓
CAMBER TUBE (COG)		●	✓		✓	✓
BACK ANGLE	✓		●	✓	✓	✓
BACK UPHOLSTERY			✓	●	✓	✓
USER CONDITION	✓	✓	✓	✓	●	✓
SEAT ANGLE	✓	✓	✓	✓	✓	●

NOTE: When changes to the left hand column occur, follow across the chart and refer to the ✓ procedure to maintain the proper stability, safety and handling of the wheelchair.

Operating Information

To determine and establish your particular safety limits, practice bending, reaching and transferring activities in several combinations in the presence of a qualified healthcare professional before attempting active use of the wheelchair.

DO NOT attempt to reach objects if you have to move forward in the seat.

DO NOT attempt to reach objects if you have to pick them up from the floor by reaching down between your knees.

DO NOT lean over the top of the back upholstery to reach objects from behind as this may cause the wheelchair to tip over.

DO NOT shift your weight or sitting position toward the direction you are reaching as the wheelchair may tip over.

DO NOT tip the wheelchair without assistance.

DO NOT attempt to stop a moving wheelchair with wheel locks. Wheel locks are not brakes.

NEVER leave an unoccupied wheelchair on an incline.

DO NOT use an escalator to move a wheelchair between floors. Serious bodily injury may occur. Before attempting to transfer in or out of the wheelchair, every precaution should be taken to reduce the gap distance. Turn both casters parallel to the object you are transferring onto. Also be certain the wheel locks are engaged to prevent the wheels from moving.

DO NOT operate on roads, streets or highways.

DO NOT climb, go up or down ramps or traverse slopes greater than 9°.

DO NOT attempt to move up or down an incline with a water, ice or oil film.

DO NOT attempt to ride over curbs or obstacles. Doing so may cause your wheelchair to turn over and cause bodily harm or damage to the wheelchair.

DO NOT attempt to lift the wheelchair by any removable (detachable) parts. Lifting by means of any removable (detachable) parts of a wheelchair may result in injury to the user or damage to the wheelchair.

DO NOT stand on the frame of the wheelchair.

Check all Allen screws that secure the footrest/raised footrest system to the wheelchair frame before using the wheelchair, especially if engaging in any contact sport.

Anti-tippers MUST be used at all times. When outdoors on wet, soft ground or on gravel surfaces, anti-tippers may not provide the same level of protection against tip over. Extra caution MUST be observed when traversing such surfaces. Inasmuch as the anti-tippers are an option on this wheelchair (you may order with or without the anti-tippers), Invacare strongly recommends ordering the anti-tippers as an additional safeguard for the wheelchair user.

Unless otherwise noted, all service and adjustments should be performed while the wheelchair is unoccupied.

ALWAYS use the handrims for self-propulsion. Inasmuch as the handrims are an option on this wheelchair (you may order with or without the handrims), Invacare strongly recommends ordering the handrims as an additional safeguard for the wheelchair user.

DO NOT use the footplate as a platform when getting in or out of the wheelchair.

Tire Pressure and Information

DO NOT use your wheelchair unless it has the proper tire pressure (p.s.i.). DO NOT overinflate the tires. Failure to follow these suggestions may cause the tire to explode and cause bodily harm. The recommended tire pressure is on the sidewall of the tire.

Replacement of the tire or tube MUST be performed by a qualified technician.

Weight Training

Invacare DOES NOT recommend the use of its wheelchairs as a weight training apparatus. Invacare wheelchairs have not been designed or tested as a seat for any kind of weight training. If occupant uses said wheelchair as a weight training apparatus, Invacare shall not be liable for bodily injury and the warranty is void.

Weight Limitation

Invacare's Top End Crossfire T6A wheelchair has a weight limitation of 250 lbs.

SECTION 2—SAFE HANDLING

“Safety and Handling” of the wheelchair requires the close attention of the wheelchair user as well as the assistant. This manual points out the most common procedures and techniques involved in the safe operation and maintenance of the wheelchair. It is important to practice and master these safe techniques until you are comfortable in maneuvering around the frequently encountered architectural barriers.

Use this information only as a “basic” guide. The techniques that are discussed on the following pages have been used successfully by many.

Individual wheelchair users often develop skills to deal with daily living activities that may differ from those described in this manual. Invacare recognizes and encourages each individual to try what works best for him/her in overcoming architectural obstacles that they may encounter, however, ALL WARNINGS and CAUTIONS given in this manual **MUST** be followed. Techniques in this manual are a starting point for the new wheelchair user and assistant with “safety” as the most important consideration for all.

Stability and Balance

⚠ WARNING

ALWAYS wear your seat positioning strap. Inasmuch as the seat positioning strap is an option on this wheelchair (you may order with or without the seat positioning strap), Invacare Top End strongly recommends ordering the seat positioning strap as an additional safeguard for the wheelchair user. The seat positioning strap is a positioning belt only. It is not designed for use as a safety device withstanding high stress loads such as auto or aircraft safety belts. If signs of wear appear, seat positioning strap **MUST be replaced **IMMEDIATELY**.**

Anti-tippers **MUST be attached at all times. Inasmuch as the anti-tippers are an option on this wheelchair (you may order with or without the anti-tippers), Invacare strongly recommends ordering the anti-tippers as an additional safeguard for the wheelchair user.**

To assure stability and proper operation of your wheelchair, you **MUST** at all times maintain proper balance. Your wheelchair has been designed to remain upright and stable during normal daily activities as long as you **DO NOT** move beyond the center of gravity.

Virtually all activities which involve movement in the wheelchair have an effect on the center of gravity. Invacare recommends using seat positioning straps for additional safety while involved in activities that shift your weight.

DO NOT lean forward out of the wheelchair any further than stability will allow. Make sure casters are pointing in the forward position whenever you lean forward. This can be achieved by advancing the wheelchair and then reversing it in a straight line.

⚠ WARNING

DO NOT attempt to reach objects if you have to move forward in the seat or pick them up from the floor by reaching down between your knees.

The position of the footrest, camber tube, back angle, the tautness of the back upholstery as well as the user's condition are directly related to the wheelchair's stability. Any change to one or any combination of the five may cause the wheelchair to decrease in stability. Use **EXTREME** caution when using a new seating position. The addition of anti-tippers may be required.

NOTE: For this procedure, refer to FIGURE 2.1.

Many activities require the wheelchair owner to reach, bend and transfer in and out of the wheelchair. These movements will cause a change to the normal balance, the center of gravity, and the weight distribution of the wheelchair.

To determine and establish your particular safety limits, practice bending, reaching and transferring activities in several combinations in the presence of a qualified health-care professional before attempting active use of wheelchair.

Proper positioning is essential for your safety. When reaching, leaning, bending forward, it is important to use the front casters as a tool to maintain stability and balance.

- Lengthening the wheelbase will increase the stability and maintain standard maneuverability of wheelchair.
- Shortening the wheelbase will decrease the stability, increase the maneuverability and distribute additional weight onto the rear wheels.

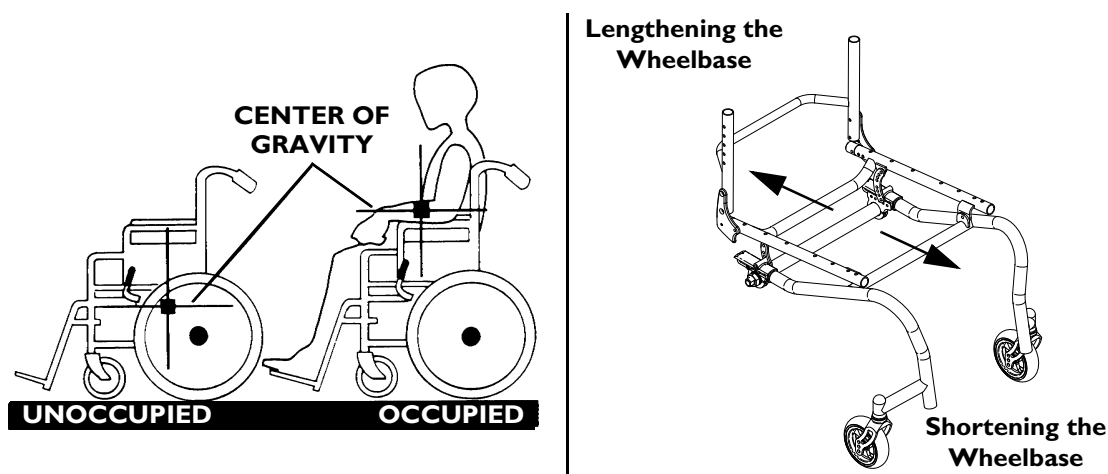

FIGURE 2.1 Stability and Balance

Coping with Everyday Obstacles

Coping with the irritation of everyday obstacles can be alleviated somewhat by learning how to manage your wheelchair. Keep in mind your center of gravity to maintain stability and balance.

A Note to Wheelchair Assistants

When assistance to the wheelchair user is required, remember to use good body mechanics. Keep your back straight and bend your knees whenever tilting the wheelchair or traversing curbs, or other impediments.

⚠ WARNING

DO NOT attempt to lift a wheelchair by lifting on any removable (detachable) parts. Lifting by means of any removable (detachable) parts of a wheelchair may result in injury to the user or damage to the wheelchair.

Also, be aware of any removable (detachable) parts. These **MUST NEVER** be used to move the wheelchair or as lifting supports, as they may be inadvertently released, resulting in possible injury to the user and/or assistant(s).

When learning a new assistance technique, have an experienced assistant help you before attempting it alone.

Reaching, Leaning and Bending - Forward

NOTE: For this procedure, refer to FIGURE 2.2.

Position the front casters so that they are extended as far forward as possible and engage wheel locks.

⚠ WARNING

DO NOT attempt to reach objects if you have to move forward in the seat or pick them up from the floor by reaching down between your knees.

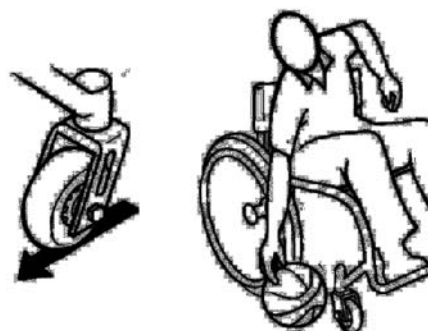

Reaching, Leaning, and Bending - Forward

Reaching, Leaning - Backwards

⚠ WARNING

DO NOT lean over the top of the back upholstery. This will change your center of gravity and may cause you to tip over.



Reaching, Leaning, and Bending - Backwards

FIGURE 2.2 Reaching, Leaning and Bending - Forward

Tipping

⚠ WARNING

DO NOT tip the wheelchair without assistance.

DO NOT let the wheelchair drop the last few inches to the ground. This could result in injury to the occupant.

When tipping the wheelchair, an assistant should grasp the back of the wheelchair on a non-removable (non-detachable) part. Inform the wheelchair occupant before tilting the wheelchair and remind him/her to lean back. Be sure the occupant's feet and hands are clear of all wheels and/or pinch points. Apply a continuous motion until the balance point is achieved. At this point, the assistant will feel a difference in the weight distribution. Turn the wheelchair in the desired direction if necessary. Slowly lower the wheelchair in one continuous movement.

Tipping - Curbs

⚠ WARNING

Invacare does not recommend that sport wheelchairs be used where traversing curbs present an obstacle. Possible injury to occupant and/or assistant(s) can occur. Transfer to an everyday use wheelchair is recommended if any such obstacles may be encountered.

NOTE: For this procedure, refer to FIGURE 2.3 on page 17.

After mastering the techniques of tipping the wheelchair, use the following method to tackle curbs, short stairs, etc.

Turn the anti-tippers, if equipped, so the wheels are facing UP. Unless the first assistant has exceptional upper body strength, it is recommended that two assistants perform this operation. The second assistant should be positioned at the front of the wheelchair lifting upward on a non-removable (non-detachable) part of the wheelchair frame when lifting the wheelchair and stabilizing the wheelchair when the wheelchair is being lowered to the ground.

The first assistant should stand on the sidewalk and turn the wheelchair so that the rear wheels are against the curb. The wheelchair should be tilted back to the balance point and, in one continuous upward movement, the rear wheels should be pulled up and over the curb. **DO NOT** return the front casters to the ground until the wheelchair has been pulled backward far enough for the front casters to clear the edge of the curb.

⚠ WARNING

When lowering the front casters of the wheelchair, DO NOT let the wheelchair drop the last few inches to the ground. This could result in injury to the occupant and/or damage to the wheelchair.

Roll the wheelchair backward and slowly lower the wheelchair in one continuous movement. DO NOT let the wheelchair drop the last few inches to the ground. This could result in injury to the occupant. Turn the anti-tippers so the wheels are facing down.

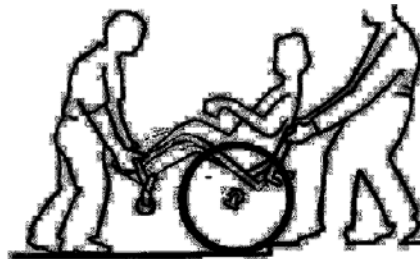

FIGURE 2.3 Tipping - Curbs

Stairways

⚠ WARNING

Concerning stairway access: Invacare does not recommend that wheelchairs be transported up or down stairways with occupant in the wheelchair. Possible injury to occupant and/or assistant(s) can occur. Transfer to an everyday use wheelchair is recommended.

DO NOT attempt to lift the wheelchair by any removable (detachable) parts. Lifting by means of any removable (detachable) parts of a wheelchair may result in injury to the user or damage to the wheelchair.

Extreme caution is advised when it is necessary to move an occupied wheelchair up or down a stairway. Invacare recommends that, if possible, the user be removed from the wheelchair prior to moving. Invacare recommends using two assistants and making thorough preparations. Make sure to use only secure, non-detachable parts for hand-held supports.

Follow this procedure for moving the wheelchair between floors when an elevator is NOT available:

1. If equipped, turn the anti-tippers up. Refer to Footrest on page 24.
2. After the wheelchair has been tilted back to the balance point, one assistant (in the rear) backs the wheelchair up against the first step, while securely grasping a non-removable (non-detachable) part of the wheelchair for leverage.
3. The second assistant, with a firm hold on a non-detachable part of the framework, lifts the wheelchair up and over the stair and steadies it as the first assistant places one foot on the next stair and repeats procedure.
4. The wheelchair should not be lowered until the last stair has been negotiated and it has been rolled away from the stairway.

5. If equipped, turn the anti-tippers down. Refer to Footrest on page 24 in this manual.

⚠ WARNING

DO NOT use an escalator to move a wheelchair between floors. Serious bodily injury may occur.

Transferring To and From Other Seats

⚠ WARNING

BEFORE attempting to transfer in or out of the wheelchair, every precaution should be taken to reduce the gap distance. Turn both casters parallel to the object you are transferring onto. Also be certain the wheel locks are engaged to help prevent the wheels from moving.

When transferring, position yourself as far back as possible in the seat. This will prevent damaged upholstery and the possibility of the wheelchair tipping forward.

NOTE: For this procedure, refer to FIGURE 2.4.

NOTE: This activity may be performed independently provided you have adequate mobility and upper body strength.

Position the wheelchair as close as possible along side the seat to which you are transferring, with the front casters parallel to it. Remove the armrest, if installed. Engage wheel locks. Shift body weight into seat with transfer.

During independent transfer, little or no seat platform will be beneath you. Use a transfer board if at all possible.

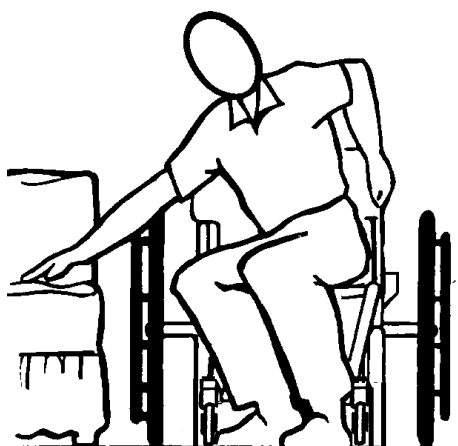

FIGURE 2.4 Transferring To and From Other Seats

SECTION 3—SAFETY INSPECTION

NOTE: Every six months, take your wheelchair to a qualified technician for a thorough inspection and servicing. Regular cleaning will reveal loose or worn parts and enhance the smooth operation of your wheelchair. To operate properly and safely, your wheelchair MUST be cared for just like any other vehicle. Routine maintenance will extend the life and efficiency of your wheelchair. Clean upholstery with mild soap and water or spray disinfectant using a sponge. DO NOT use bleach or wash in a washing machine.

Safety Inspection Checklist

CAUTION

As with any vehicle, the wheels and tires should be checked periodically for cracks and wear, and should be replaced if damaged.

Initial adjustments should be made to suit your personal body structure and preference. Thereafter follow these maintenance procedures:

Inspect Initially

- Ensure wheelchair rolls straight (no excessive drag/pull to one side).
- Ensure wheel locks DO NOT interfere with tires when rolling.
- Ensure pivot points are free of wear and looseness.
- Ensure wheel locks are easy to engage and prevent the wheels from moving.
- Ensure that the casters are free of debris.
- Inspect seat and back upholstery for rips or sagging.
- Inspect upholstery fastening flaps to ensure they securely latch.
- Inspect seat positioning strap for any signs of wear. Ensure buckle latches. Verify hardware that attaches strap to frame is secure and undamaged. Replace if necessary.
- Ensure hand grips (if equipped) are not loose.
- Ensure quick release axles and camber inserts are clean.
- Ensure camber bar mounting clamps are securely tightened.
- Ensure quick/quad release axles lock properly.
- Ensure no excessive side movement or binding when lifted and spun.
- Inspect handrims for signs of rough edges or peeling.
- Inspect spokes for bent or broken spokes.
- Ensure all spokes are uniformly tight.
- Clean upholstery and armrests.

SECTION 3—SAFETY INSPECTION

- Inspect wheel/fork assembly for proper tension by spinning caster; caster should come to a gradual stop.
- Loosen/tighten locknut if wheel wobbles noticeably or binds to a stop.
- Ensure wheel bearings are clean and free of moisture.
- Inspect tires for flat spots and wear.
- If pneumatic tires check for proper inflation.
- Check that all labels are present and legible. Replace if necessary.

Inspect/Adjust Weekly

- Ensure wheel locks are easy to engage and prevent the wheels from moving.
- Ensure that the casters are free of debris.
- Ensure hand grips (if equipped) are not loose.
- Ensure quick release axles and camber inserts are clean.
- Ensure quick/quad release axles lock properly.
- Inspect handrims for signs of rough edges or peeling.
- Inspect spokes for bent or broken spokes.
- Ensure All spokes uniformly tight.
- Inspect wheel/fork assembly for proper tension by spinning caster; caster should come to a gradual stop.
- Inspect tires for flat spots and wear.
- If pneumatic tires check for proper inflation.

Inspect/Adjust Monthly

- Ensure wheel locks DO NOT interfere with tires when rolling.
- Ensure that the casters are free of debris.
- Ensure pivot points are free of wear and looseness.
- Inspect upholstery fastening flaps to ensure they securely latch.
- Inspect seat positioning strap for any signs of wear. Ensure buckle latches. Verify hardware that attaches strap to frame is secure and undamaged. Replace if necessary.
- Ensure camber bar mounting clamps are securely tightened.
- Loosen/tighten locknut if wheel wobbles noticeably or binds to a stop.
- Ensure wheel bearings are clean and free of moisture.

Inspect/Adjust Periodically

- Ensure wheelchair rolls straight (no excessive drag/pull to one side).
- Ensure wheel locks are easy to engage.
- Ensure that the casters are free of debris.
- Inspect seat and back upholstery for rips or sagging.
- Ensure camber bar mounting clamps are securely tightened.
- Ensure no excessive side movement or binding when lifted and spun.
- Inspect handrims for signs of rough edges or peeling.
- Clean upholstery and armrests.
- Ensure wheel bearings are clean and free of moisture.
- Check that all labels are present and legible. Replace if necessary.

Troubleshooting

CHAIR VEERS RIGHT	CHAIR VEERS LEFT	SLUGGISH TURN OR PERFORMANCE	CASTER FLUTTERS	SQUEAKS AND RATTLES	LOOSENESS IN CHAIR	SOLUTIONS
X	X	X	X			Check tires for correct and equal pressure.
		X	X	X	X	Check for loose stem nuts.
				X	X	Check spokes and nipples.
X	X		X			Check that both casters contact the ground at the same time.

Maintenance

Maintenance Safety Precautions

⚠ WARNING

After ANY adjustments, repair or service and BEFORE use, make sure all attaching hardware is tightened securely - otherwise injury or damage may occur.

CAUTION

DO NOT overtighten hardware attaching to the frame. This could cause damage to the frame tubing.

Suggested Maintenance Procedures

1. Before using your wheelchair, make sure all nuts and bolts are tight. Check all parts for damage or wear and replace. Check all parts for proper adjustment.
 2. Keep quick/quad-release axles free of dirt and lint to ensure positive locking and proper operation. Refer to Adjusting Quick-Release Axles on page 46 or Adjusting Quad-Release Handles on page 47.
-

⚠ WARNING

DO NOT use WD-40[®], 3-in-1 oil[®], or other penetrating lubricants on quick-release axles or camber inserts. Otherwise, binding and/or damage to the wheelchair may occur.

3. Clean quick-release axles and camber inserts once a week with a Teflon[®] lubricant.
-

⚠ WARNING

DO NOT use your wheelchair unless it has the proper tire pressure (p.s.i.).

DO NOT overinflate the tires. Failure to follow these suggestions may cause the tire to explode and cause bodily harm. The recommended tire pressure is on the sidewall of the tire.

4. Recommended tire pressure is listed on the sidewall of the tire.
-

CAUTION

As with any vehicle, the wheels and tires should be checked periodically for cracks and wear, and should be replaced if damaged.

5. The wheels, casters and tires should be checked periodically for cracks and wear, and should be replaced when necessary. Contact a qualified technician or Invacare customer support at the telephone numbers on the back of this manual.
-

6. Regularly check for loose spokes in the rear wheels. If loose, have them adjusted. Contact a qualified technician or Invacare customer support at the telephone numbers on the back of this manual.
7. Periodically check handrims to ensure they are secured to the rear wheels. Refer to Handrim Replacement on page 48.
8. Periodically adjust wheel locks as tires wear. Refer to Replacing/Adjusting the Wheel Locks on page 42.
9. Periodically check caster wheel bearings to make sure they are clean and free from moisture. Use a Teflon[®] lubricant if necessary.
10. Check upholstery for sagging, rips or tears.
11. Clean upholstery with mild soap and water.
12. Replace any labels that are missing, worn or torn.

SECTION 4—FOOTREST

⚠ WARNING

After **ANY** adjustments, repair or service and **BEFORE** use, make sure all attaching hardware is tightened securely - otherwise injury or damage may occur.

ALWAYS perform this procedure in the presence of an assistant. The position of the footrest, camber tube, seat angle, back angle, the tautness of the back upholstery as well as the user's condition are directly related to the wheelchairs stability. Any change to one or any combination of the five may cause the wheelchair to decrease in stability. Use **EXTREME** caution when using a new seating position. The addition of anti-tippers may be required.

Check **ALL** allen screws that secure the footrest/raised footrest system to the wheelchair frame to make sure they are securely tightened **BEFORE** using the wheelchair. **ESPECIALLY** if engaging in **ANY** contact sport.

The footrest assembly **MUST** be at least 1 $\frac{3}{4}$ -inches above the ground/floor to avoid hitting protruding objects when using this wheelchair.

Adjusting/Replacing Standard Footrest

NOTE: For this procedure, refer to FIGURE 4.1.

1. Loosen the allen screw of the two clamps that secure the footrest to the wheelchair frame.

Replacing the Footrest

1. Remove existing footrest.
2. Install new footrest.

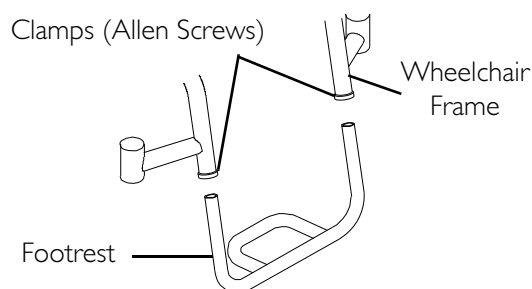

FIGURE 4.1 Adjusting/Replacing Standard Footrest

⚠ WARNING

The standard footrest has an open hoop. A footplate cover is recommended for wheelchair users that have leg spasticity or whose feet have a possibility of falling through the footrest hoop. A calf strap is provided with each wheelchair to prevent the feet from slipping backwards off of the footrest. Be sure the calf strap is secure when using the wheelchair.

Adjusting the Footrest

1. Position new/existing footrest to desired height.
2. Tighten the allen screw of the two clamps that secure the footrest to the wheelchair frame.

Replacing/Adjusting Optional Adjustable Angle Footrest

NOTE: For this procedure, refer to FIGURE 4.2 on page 26.

Replacing the Footrest

1. Loosen, but DO NOT remove the allen screw of the two clamps that secure the footrest to the wheelchair frame.
2. Slide the existing footrest tubes out of the wheelchair frame and install new footrest by reversing this step.
3. Position the new footrest to a determined height.
4. Tighten the allen screw of the two clamps that secure the footrest to the wheelchair frame.
5. Adjust the footplate to the desired position. Refer to [Adjusting Footplate Angle](#) on page 25 and/or [Adjusting Footplate Depth](#) on page 25.

Adjusting Footplate Angle

1. Loosen, but DO NOT remove the two mounting screws and locknuts (not shown) that secure the footplate to the two footrest tubes.
2. Position the footplate to the necessary angle to accommodate the user.
3. Retighten the two mounting screws and locknuts.

NOTE: The locknuts should lie in the channel of the footplate clamp.

Adjusting Footplate Depth

1. Remove the two mounting screws and locknuts (not shown) that secure footplate to the footrest tubes.

NOTE: Observe the angle of footplate for reinstallation.

2. Move the footplate to one of two mounting positions to accommodate the user.
3. Using the two mounting screws and locknuts, secure the footplate to the footrest tubes.

NOTE: The locknuts should lie in the channel of the footplate half clamp.

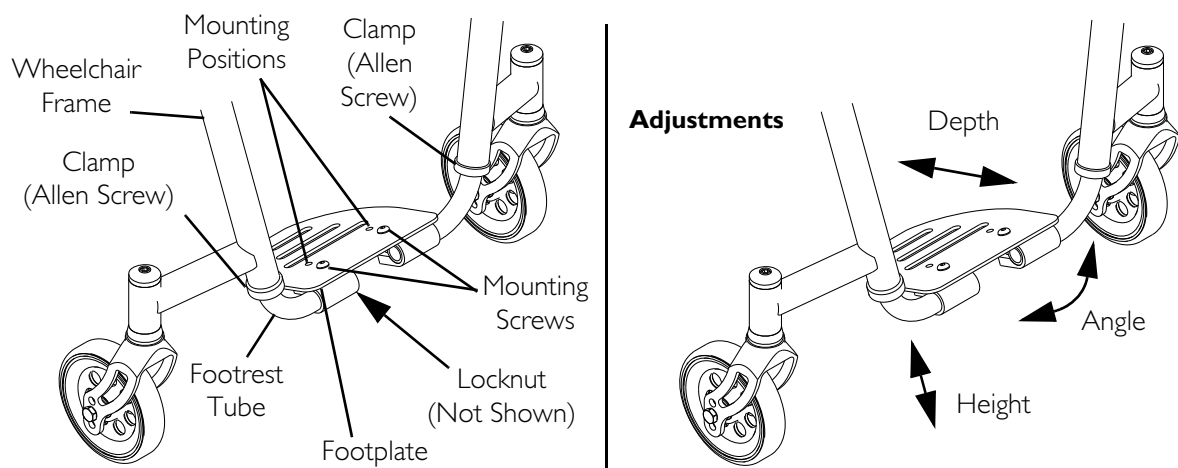

FIGURE 4.2 Replacing/Adjusting Optional Adjustable Angle Footrest

SECTION 5—ARMS

⚠ WARNING

After ANY adjustments, repair or service and BEFORE use, make sure all attaching hardware is tightened securely - otherwise injury or damage may occur.

DO NOT attempt to lift or tilt a wheelchair by using any removable (detachable) parts. Lifting by means of any removable (detachable) parts of a wheelchair may result in injury to the user or damage to the wheelchair.

Installing the Swingaway Padded Armrest Socket

NOTE: For this procedure, refer to FIGURE 5.1.

1. Fold down the back. Refer to Unfolding/Folding the Back on page 31.
2. Remove the back stop insert by removing the rear seat upholstery mounting screw, short mounting screw and the long mounting screw, plastic washer, coved spacer, washer, and locknut from the back cane mounting bracket and seat rail (Detail "A").

NOTE: The coved spacer is located between the back cane mounting plate and the seat rail.

3. Remove split ring, plunger pin and spring from back stop insert and install into the new back stop insert with arm socket (if not supplied).
 4. Secure the new back stop insert with arm socket in to the rear of the seat rail with the short mounting screw, long mounting screw, plastic washer, coved spacer, washer, and locknut from the back cane mounting bracket (Detail "B").
 5. Install rear seat upholstery mounting screw. DO NOT tighten.
 6. Tighten long mounting screw enough to secure the back to the seat rail, while allowing the back to fold properly.
 7. Securely tighten the locknut on the long mounting screw while holding the long mounting screw from rotating.
 8. Securely tighten the short mounting screw and rear seat upholstery mounting screw.
 9. Repeat STEPS 1 - 5 for the other arm.
-

⚠ WARNING

After unfolding the back, ensure that the plunger pins are fully engaged in the mounting holes of the adjustment square in the back cane mounting brackets (Detail "C"). Otherwise, serious injury could result.

10. Unfold back to upright position. Refer to Unfolding/Folding the Back on page 31.

NOTE: An audible "click" will be heard when the plunger pins are fully engaged into the adjustment square and the split ring will be flush up against the back stop insert.

NOTE: The back should have a small amount of movement when locked in the open position. Plunger pins should snap in and release easily without resistance.

DETAIL "A"

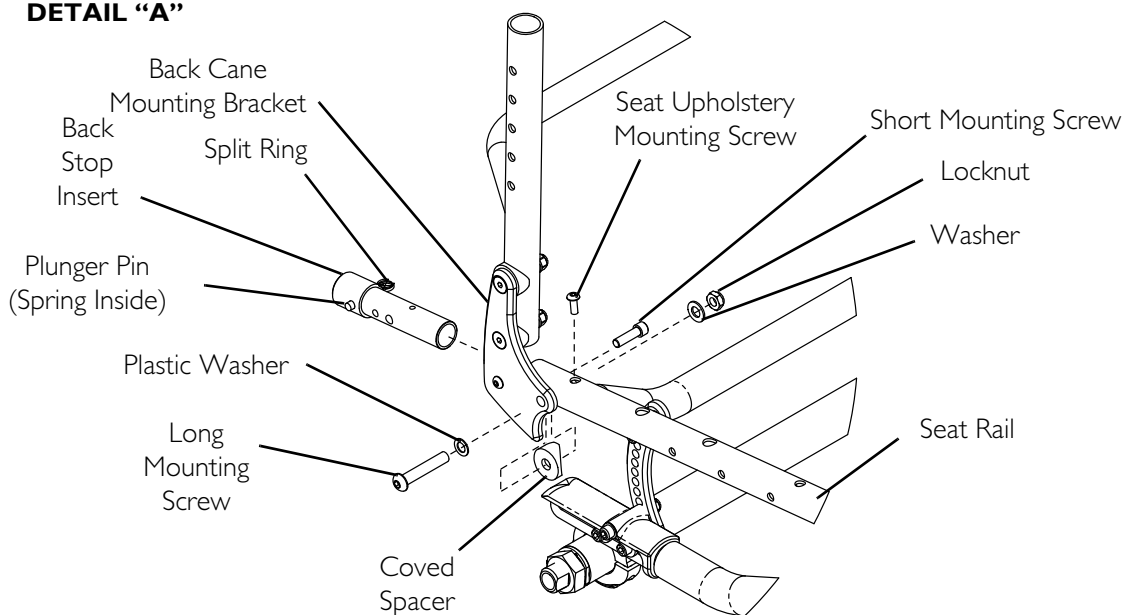

DETAIL "B"

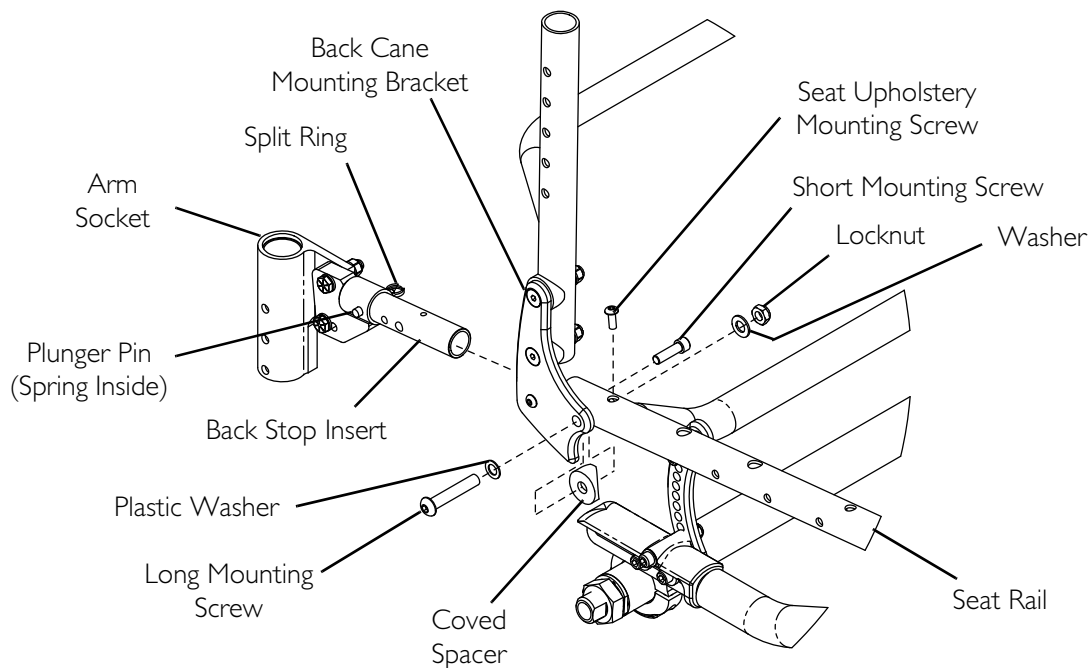

DETAIL "C"

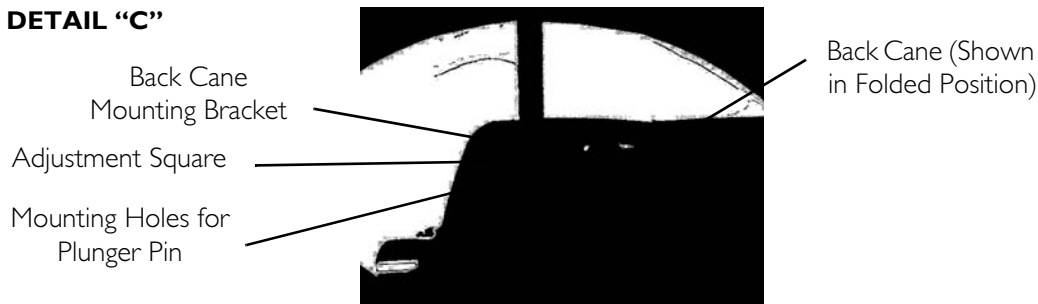

FIGURE 5.1 Installing the Swingaway Padded Armrest Socket

Adjusting Swingaway Padded Armrest Height

NOTE: For this procedure, refer to FIGURE 5.2.

1. Remove the swingaway padded armrest from the arm socket.
2. Remove the mounting bolt, two washers and locknut mounted in the arm socket that determine the swingaway padded armrest height.
3. Reposition mounting bolt and one washer to one of three positions in the arm socket depending on the desired height.
4. Retighten the mounting bolt and washer to the arm socket with the remaining washer and locknut.
5. Reinstall the swingaway padded armrest into the arm socket.
6. Repeat STEPS 1-5 for the opposite side, if necessary.

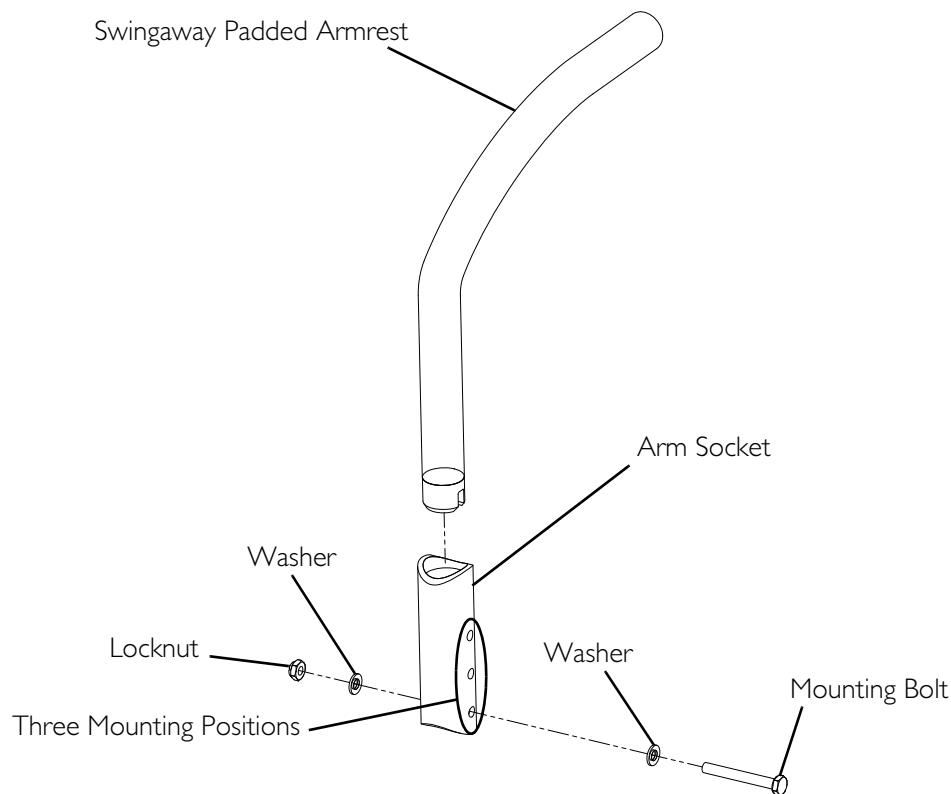

FIGURE 5.2 Adjusting Swingaway Padded Armrest Height

Removing/Installing and Adjusting T-Arms

NOTE: For this procedure, refer to FIGURE 5.3.

Removing/Installing T-Arms

NOTE: To remove the T-arm, reverse this procedure.

1. Align the T-arm with the socket in the T-arm bracket on the wheelchair frame.
2. Slide the T-arm into the T-arm bracket until the height adjustment screw rests on the top on the T-arm bracket.

Adjusting T-Arm Height

NOTE: For this procedure, refer to FIGURE 5.3.

1. Remove the T-arm. Refer to Removing/Installing T-Arms on page 30.
2. Remove the height adjustment screw and locknut from the height adjustment hole.
3. Reinstall the height adjustment screw and locknut in one of the three height adjustment holes on the t-arm of the armrest. Secure tightly.
4. Reinstall the T-arm. Refer to Removing/Installing T-Arms on page 30.

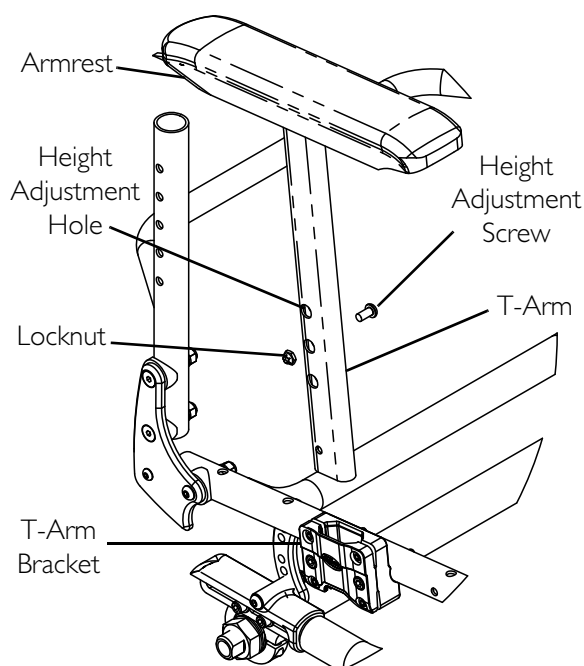

FIGURE 5.3 Adjusting T-Arm Height

Adjusting T-Arm Position

NOTE: For this procedure, refer to FIGURE 5.4

NOTE: T-arm can be mounted in one of two locations on the seat rail.

1. Remove the two mounting screws and locknuts that secure the T-arm bracket to the seat rail.
2. Install T-arm bracket in desired mounting position on seat rail.
3. Secure the T-arm bracket to the seat rail with two mounting screws and locknuts. Securely tighten.

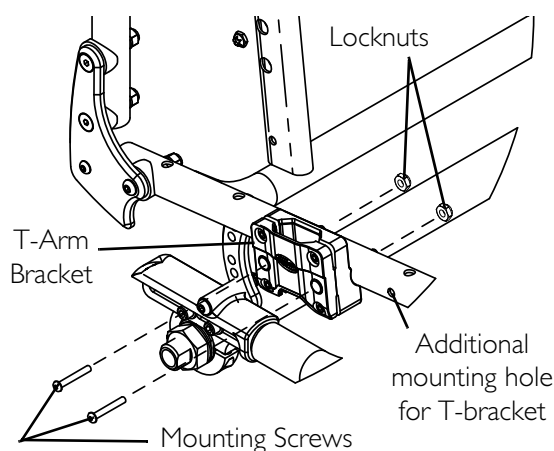

FIGURE 5.4 Adjusting T-Arm Position

SECTION 6—BACK

⚠ WARNING

ALWAYS perform these procedures in the presence of an assistant. The position of the footrest, camber tube, seat angle, back angle, the tautness of the back upholstery as well as the user's condition are directly related to the wheelchairs stability. Any change to one or any combination of the five may cause the wheelchair to decrease in stability. Use **EXTREME** caution when using a new seating position. The addition of anti-tippers may be required.

After **ANY** adjustments, repair or service and **BEFORE** use, make sure all attaching hardware is tightened securely - otherwise injury or damage may occur.

Unfolding/Folding the Back

⚠ WARNING

After unfolding the back, ensure that the plunger pins are fully engaged in the mounting holes of the adjustment square in the back cane mounting brackets (Detail "A" in FIGURE 6.2). Back **MUST** be locked securely in place. Otherwise, serious injury could result.

NOTE: For this procedure, refer to FIGURE 6.1.

1. To fold the back, pull up on the back release cord and push the back toward the seat of the wheelchair (Detail "A").
2. To unfold the back, pull up on the back release cord and lift the back away from the seat until the back locks into place (Detail "B").

NOTE: An audible "click" will be heard when the plunger pins fully engage into the adjustment square and the split ring will be flush up against the back stop insert.

NOTE: The back should have a small amount of movement when locked in the open position. Plunger pins should snap in and release easily without resistance.

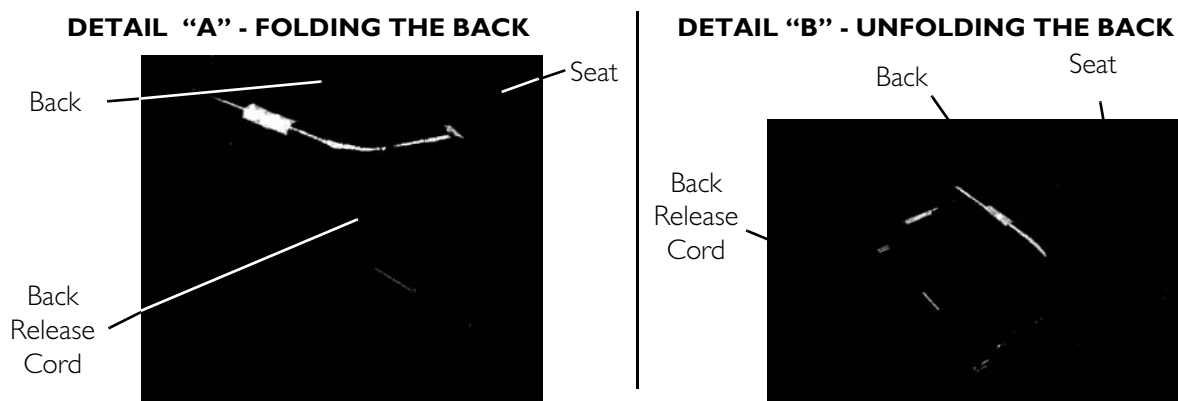

FIGURE 6.1 Unfolding/Folding the Back

Back Angle Adjustment

NOTE: For this procedure, refer to FIGURE 6.2 on page 33.

NOTE: Perform this procedure on both sides of the wheelchair at the same time.

1. Fold down the back. Refer to Unfolding/Folding the Back on page 31.
2. Loosen the jam nut on the placement screw located at the bottom of the back cane (Detail “A”).
3. Tighten the placement screw so that the screw and jam nut are snug against the bottom of the back cane (Detail “B”).
4. Remove the mounting screw that secures the adjustment square to the back angle plate (Details “B” and “C”).
5. Remove the adjustment square from the back angle plate (Detail “C”).

NOTE: Note the indent on the adjustment square (Details “D” and “E”). When the adjustment square is positioned in the back angle plate, the number that is located directly next to the indent will be the angle of the back. One side of the adjustment square provides back angles of -8° , 0° and -4° . (Detail “D”). Flip the adjustment square over to obtain back angles of 8° , 4° and 0° (Detail “E”).

⚠ WARNING

If the adjustment square is installed into the back angle plate so that a number does not appear next to the indent, DO NOT use this position, otherwise injury will occur. This position of the adjustment square does not allow the locking pins to lock into position when the back is raised.

6. Position the adjustment square in the back plate with the indent located underneath the desired back angle (Details “D” and “E”).
7. Secure the adjustment square to the back angle plate with the mounting screw. Tighten securely.
8. Repeat STEPS 2-6 for remaining back cane.

⚠ WARNING

After unfolding the back, ensure that the plunger pins are fully engaged in the mounting holes of the adjustment square in the back cane mounting brackets (Detail “A”). Otherwise, serious injury could result.

9. Unfold the back until the plunger pins lock into the mounting holes in the adjustment square.
10. Unthread the placement screw until head of screw rests on seat rail.
11. Completely tighten jam nut up against bottom of back cane.

NOTE: When adjusted properly, the back should have a small amount of movement when locked in the open position. Plunger pins should snap in and release easily without resistance.

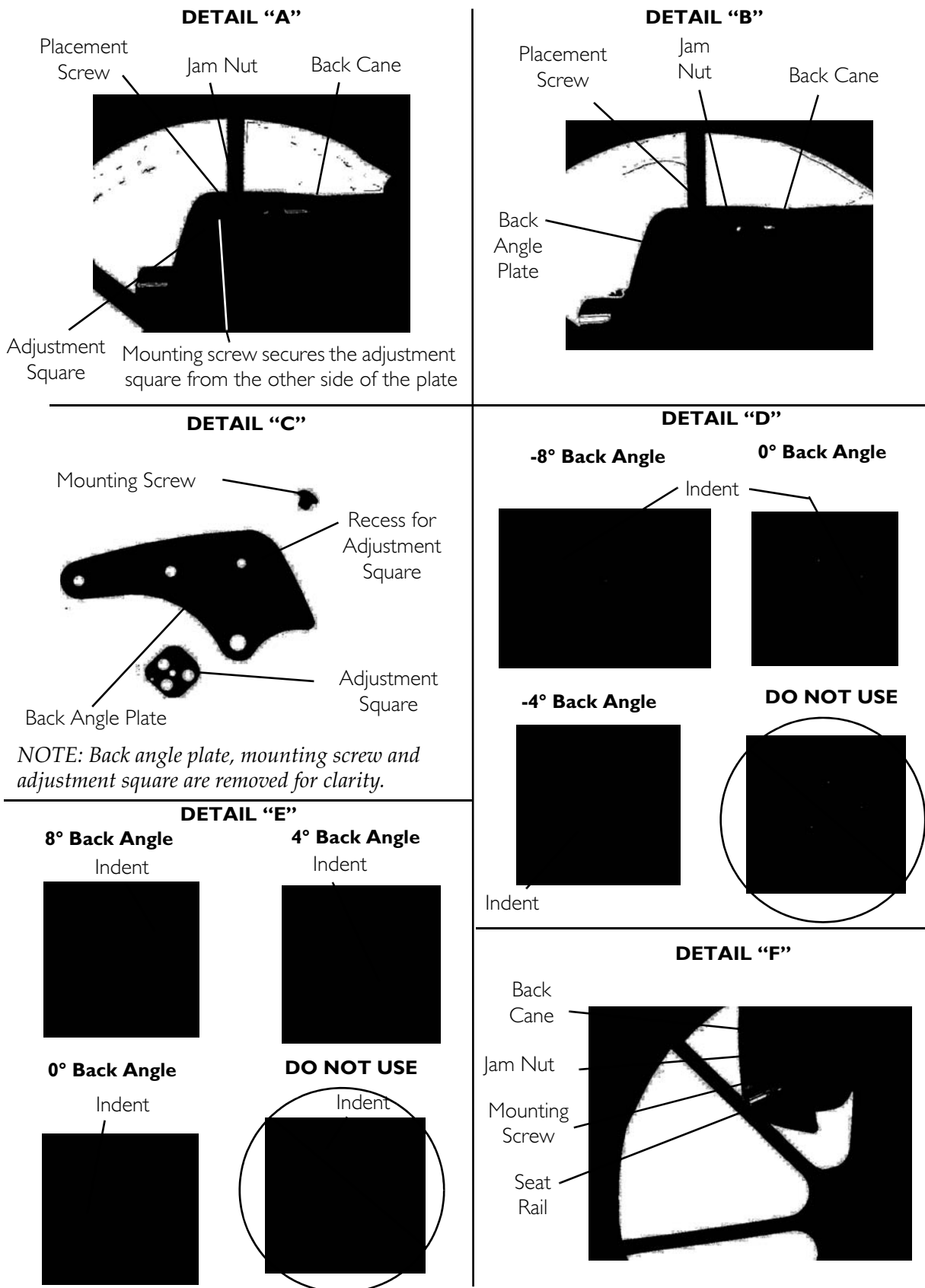

FIGURE 6.2 Back Angle Adjustment

Adjustable Tension Back Upholstery

⚠ WARNING

ALWAYS perform these procedures in the presence of an assistant. The position of the footrest, camber tube, seat angle, back angle, the tautness of the back upholstery as well as the user's condition are directly related to the wheelchairs stability. Any change to one or any combination of the five may cause the wheelchair to decrease in stability. Use **EXTREME** caution when using a new seating position. The addition of anti-tippers may be required.

NOTE: For this procedure, refer to FIGURE 6.3.

The Back Upholstery Cover

NOTE: The back upholstery cover is designed for three reasons:

- The first is as a modesty cover.
- The second is to keep the cushion from sliding out of the back of the wheelchair.
- The third is a sacral support depending upon how far or tight the flap is pulled under the seat cushion.
- The adjuster fastening straps can be adjusted at various levels of tension to accommodate individual end-users.

Adjusting the Tautness of the Back

NOTE: The adjustable tension back upholstery consists of an upper and lower (lumbar) section.

To adjust the back tension, perform the following

1. Lift back upholstery cover up and flip over toward front of wheelchair
2. Tighten or loosen the adjuster fastening straps.



FIGURE 6.3 Adjustable Tension Back Upholstery

Removing/Installing the Back Upholstery Cover, Adjustable Tension Back Upholstery and Lumbar Strap

NOTE: For this procedure, refer to FIGURE 6.4.

NOTE: If replacing the back upholstery cover, adjustable tension back upholstery and/or lumbar strap, remove the existing upholstery/lumbar strap and install the new upholstery/lumbar strap.

Removing the Back Upholstery Cover

1. Remove the seat cushion, if applicable.
2. Pull the back upholstery cover away from the adjustable tension back upholstery separating the fastening strips of the back upholstery cover from the fastening strips of the adjustable tension back upholstery and seat (Details “A” and “B”).
3. Remove back upholstery cover from wheelchair.

Removing the Adjustable Tension Back Upholstery

1. Remove the back upholster cover. Refer to Removing the Back Upholstery Cover.
2. Slide adjustable tension back upholstery off back canes (Details “C” and “D”).

Removing the Lumbar Strap

1. Remove the back upholster cover. Refer to Removing the Back Upholstery Cover.
2. Fold back forward. Refer to Unfolding/Folding the Back on page 31.
3. Loosen the top mounting screw but DO NOT remove (Detail “E”).
4. Remove the lower mounting screw, coved spacer, washer and locknut from each back cane (Detail “E”).
5. Slide lumbar strap off back canes (Details “D” and “E”).

Installing the Lumbar Strap

1. Install lumbar strap (Details “D” and “E”).
2. Install lower mounting screw, coved spacer, washer and locknut onto each back cane (Detail “E”).
3. Tighten the top and bottom mounting screws (Detail “E”).
4. Return back to upright position. Refer to Unfolding/Folding the Back on page 31.
5. Install the back upholstery. Refer to Removing the Back Upholstery Cover

Installing the Adjustable Tension Back Upholstery

1. Install the adjustable tension back upholstery onto the back canes (Details “D”, “F”, and “A”).

Installing the Back Upholstery Cover

1. Install back upholstery cover onto the adjustable tension back ensuring the fastening strips on the back upholstery cover are aligned with the fastening strips of the adjustable tension back and seat (Detail “F”).

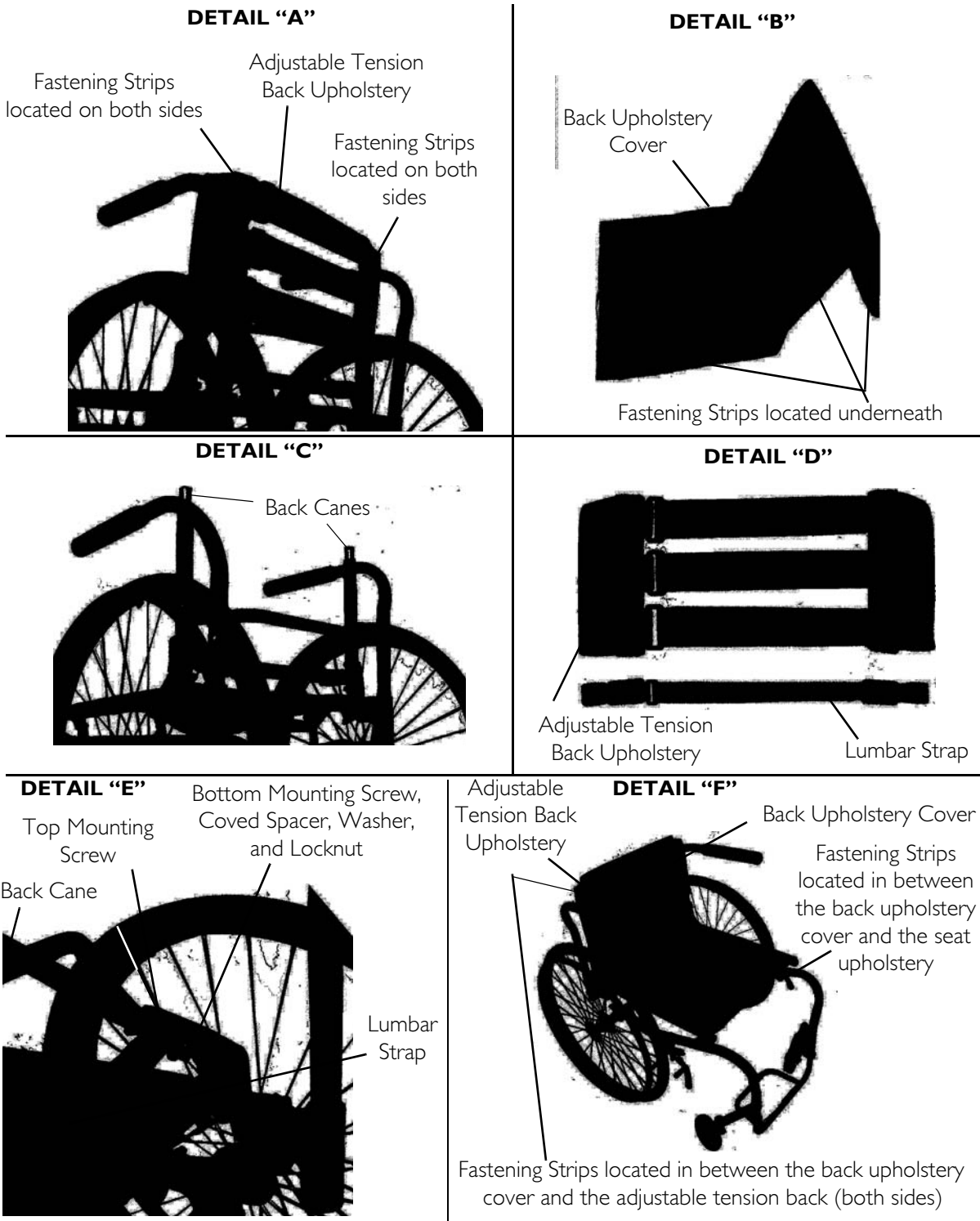

FIGURE 6.4 Removing/Installing the Back Upholstery Cover, Adjustable Tension Back Upholstery and Lumbar Strap

Removing/Installing Foldover Back Upholstery

⚠ WARNING

ALWAYS perform these procedures in the presence of an assistant. The position of the footrest, camber tube, seat angle, back angle, the tautness of the back upholstery as well as the user's condition are directly related to the wheelchairs stability. Any change to one or any combination of the five may cause the wheelchair to decrease in stability. Use **EXTREME** caution when using a new seating position. The addition of anti-tippers may be required.

NOTE: For this procedure, refer to FIGURE 6.5.

Removing Foldover Back Upholstery

1. Unfasten the two fastening flaps that secure the bottom of the existing back upholstery to the back canes.
2. Unfold the top of the back upholstery.
3. Lift up on the existing back upholstery and remove from the wheelchair.

Installing Foldover Back Upholstery

1. Install the new back upholstery onto the back canes.
2. Wrap the end of a fastening flap around the back cane.
3. Insert the end of the fastening flap through the loop.
4. Wrap the fastening flap around the back cane again and press firmly to secure.
5. Fold the top of the back upholstery down over the back canes towards the front of the wheelchair.
6. Press firmly to secure the fastening strips.

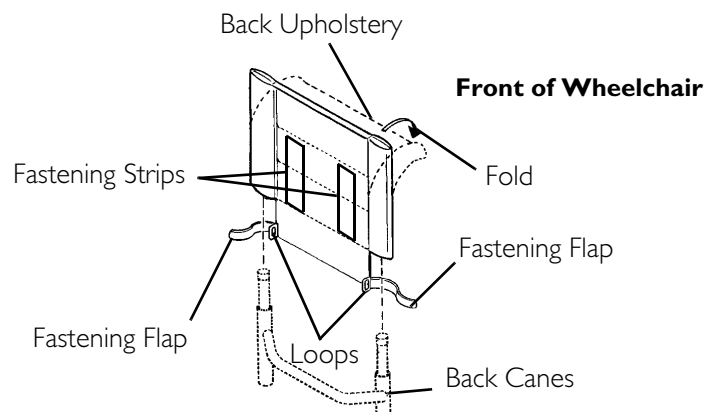

FIGURE 6.5 Removing/Installing Foldover Back Upholstery

Back Height Adjustment

NOTE: For this procedure, refer to FIGURE 6.6

NOTE: Observe the tautness of the back upholstery for reinstallation.

1. Remove the back upholstery cover and adjustable tension back upholstery. Refer to [Removing/Installing the Back Upholstery Cover, Adjustable Tension Back Upholstery and Lumbar Strap](#) on page 35.

⚠ WARNING

Adjustment pin MUST be protruding through hole in back cane.

Ensure that both back cane inserts are at the same height BEFORE reassembling the wheelchair.

2. Press the adjustment pin on the back cane insert tube in and adjust the back height to one of four heights depending on original back height:

HOLE* NUMBER	BACK HEIGHT (IN INCHES)				
	8 - 11	10 - 14	12-16	14 - 18	16-20
1	8	10	12	14	16
2	9	11	13	15	17
3	10	12	14	16	18
4	11	13	15	17	19
5	NA	14	16	18	20

*NOTE: Holes numbered from bottom to top for reference only. (There are no numbers on the back canes.)

1. Reinstall the back upholstery cover and adjustable tension back upholstery. Refer to [Removing/Installing the Back Upholstery Cover, Adjustable Tension Back Upholstery and Lumbar Strap](#) on page 35.
2. Check the tautness of the back. Refer to [Adjusting the Tautness of the Back](#) on page 34.

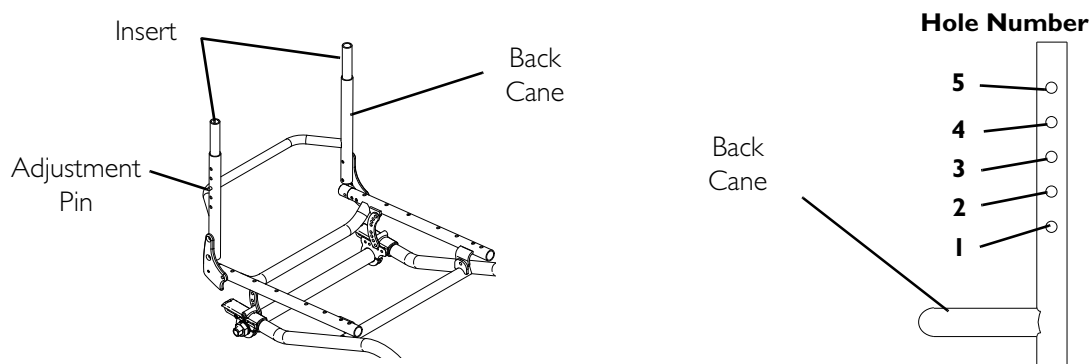

FIGURE 6.6 Back Height Adjustment

SECTION 7—SEAT

⚠ WARNING

ALWAYS perform these procedures in the presence of an assistant. The position of the footrest, camber tube, seat angle, back angle, the tautness of the back upholstery as well as the user's condition are directly related to the wheelchairs stability. Any change to one or any combination of the five may cause the wheelchair to decrease in stability. Use **EXTREME** caution when using a new seating position. The addition of anti-tippers may be required.

After **ANY** adjustments, repair or service and **BEFORE** use, make sure all attaching hardware is tightened securely - otherwise injury or damage may occur.

Replacing Seat Upholstery

NOTE: For this procedure, refer to FIGURE 7.1 on page 40.

1. Remove the seat cushion from the wheelchair.
2. Remove the mounting screws that secure the seat upholstery to the seat frame.
3. Lift up on the back upholstery cover separating the fastening strips of the back upholstery cover from the fastening strips of the seat (Detail "A").
4. Remove the existing seat upholstery.
5. Install new seat upholstery and secure in place with mounting screws. Tighten securely.
6. Install the seat cushion onto the wheelchair.

WHEELCHAIR DEPTH	NUMBER OF SCREWS
14 to 15-inches	10
16 to 17-inches	12
18-inches	14
19 to 20-inches	16

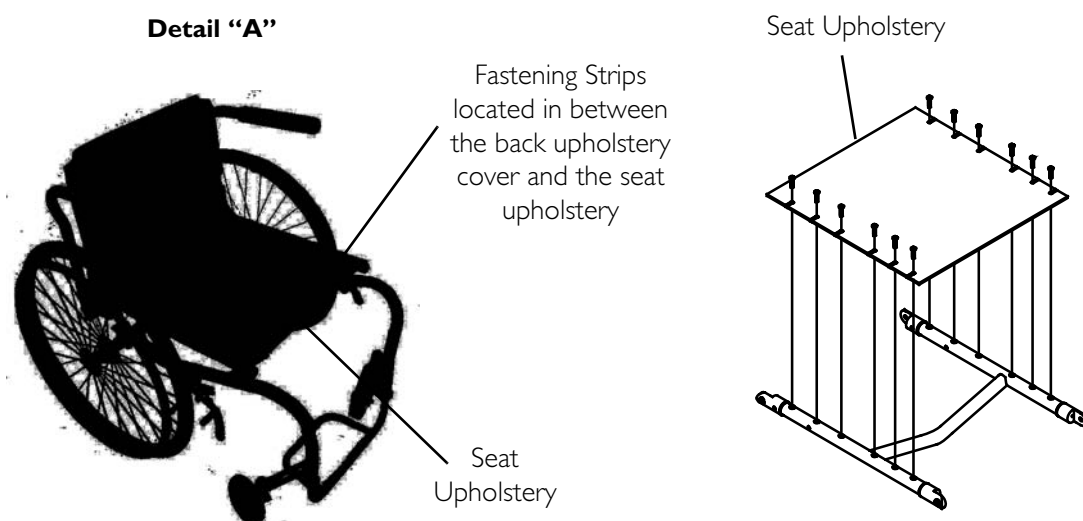

FIGURE 7.1 Replacing Seat Upholstery

Seat Angle Adjustment

NOTE: For this procedure, refer to FIGURE 7.2 on page 41.

NOTE: The seat angle can be changed by raising or lowering the rear of the seat frame relative to the side frame.

1. Fold the back. Refer to Unfolding/Folding the Back on page 31.
2. Flip wheelchair upside down.
3. Loosen, but DO NOT remove, the two mounting screws that secure the front of the seat frame to the side frame.
4. On the top of each crescent link, remove the locknut and washer from the mounting screw.
5. On the bottom of each crescent link, remove the locknut and washer from the mounting screw.
6. Adjust seat angle by performing one of the following:
 - Moving top mounting screws to a new adjustment hole in each crescent link.
 - Moving bottom mounting screws to a new adjustment hole in the crescent link.
 - Moving both mounting screws to a new adjustment hole in the crescent link.

NOTE: Mounting screws in both crescent links MUST be adjusted to the same adjustment hole.

7. Once seat angle has been adjusted, install one washer and one locknut onto each mounting screw in the crescent links.
8. Securely tighten all four mounting screws and locknuts.
9. Securely tighten both mounting screws and locknuts that secure the front of the seat frame to the side frame.

10. Position wheelchair right side up.
11. Unfold back. Refer to Unfolding/Folding the Back on page 31.
12. Check for stability. Refer to Stability Warning on page 10.

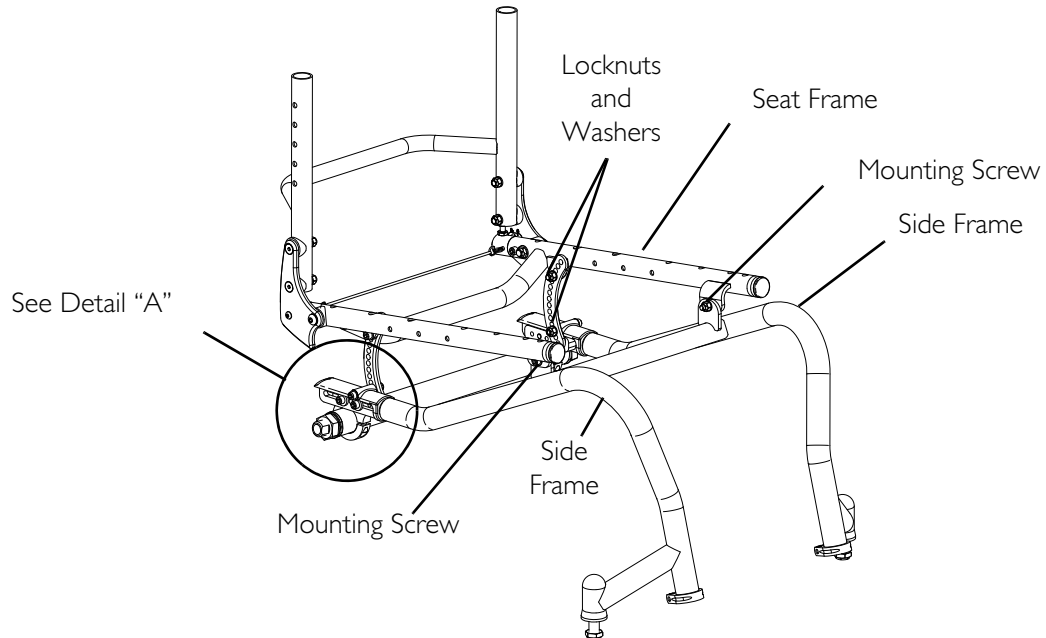
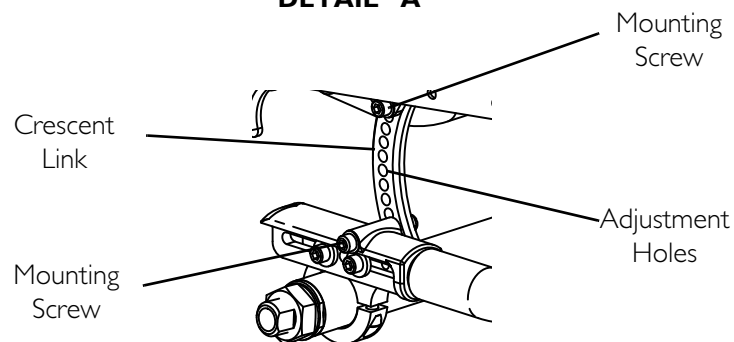
**DETAIL "A"****FIGURE 7.2** Seat Angle Adjustment

SECTION 8—WHEEL LOCKS

⚠ WARNING

After any adjustments, repair or service and before use, make sure all attaching hardware is tightened securely - otherwise injury or damage may result.

Replacing/Adjusting the Wheel Locks

⚠ WARNING

If wheel locks **DO NOT** hold the occupied wheelchair in place contact a qualified technician - otherwise injury or damage may occur.

NOTE: For this procedure, refer to FIGURE 8.1 on page 43.

NOTE: Before adjusting or replacing wheel locks, ensure that the tires are inflated to the recommended psi on the sidewall of the tire.

Replacing the Wheel Lock

1. Loosen the two mounting screws and remove the existing wheel lock from the wheelchair.
2. Using the two mounting screws, install the new wheel lock. Securely tighten.

Adjusting the Wheel Lock

1. Engage the wheel locks.

NOTE: Any wheel lock adjustment should embed the wheel lock shoe at least 3/16-inch into the pneumatic tire (1/8-inch for urethane wheels) when engaged.

2. If necessary, loosen the two mounting screws that secure the wheel locks to the wheelchair frame and adjust position of the wheel lock until the 3/16-inch (1/8-inch for urethane wheels) measurement is obtained for correct wheel lock adjustment.
3. Securely tighten the two mounting screw(s).
4. Engage the wheel locks and push against the wheelchair and determine if the wheel locks engage the tires enough to hold the wheelchair.
5. Repeat the above procedures until the wheel locks hold the wheelchair.

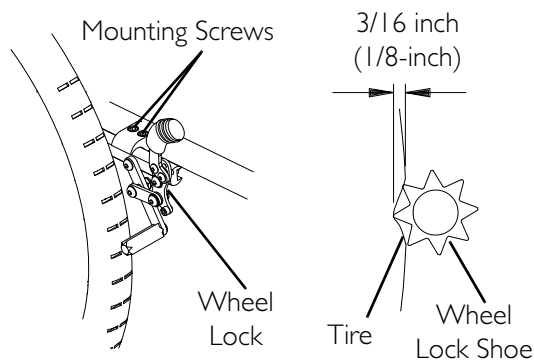
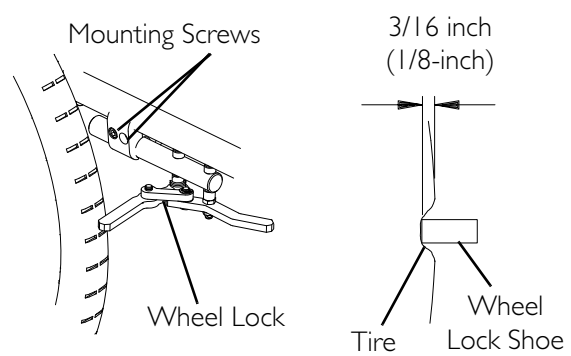
Push-to-Lock or Pull-to-Lock Wheel Locks**Under Mount Wheel Lock****FIGURE 8.1** Replacing/Adjusting the Wheel Locks

Changing Wheel Lock Handle Position

NOTE: For this procedure, refer to FIGURE 8.2.

1. Loosen, but DO NOT remove, the rear handle mounting screw.
2. Remove the front handle mounting screw and locknut.
3. Align the front handle mounting hole with one of three desired mounting positions on the wheel lock.
4. Using the front handle mounting screw and locknut, secure the handle to the wheel lock.
5. Securely tighten the front and rear handle mounting screws and locknuts.
6. Repeat STEPS 1-5 on remaining wheel lock handle.

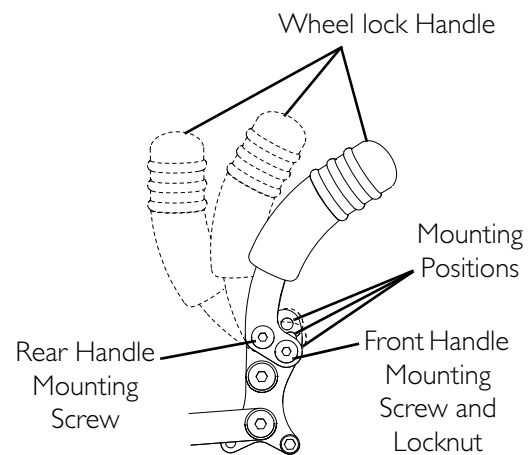
**FIGURE 8.2** Changing Wheel Lock Handle Position

Converting Wheel Lock From Push-to-Lock to Pull-to-Lock or Pull-to-Lock to Push-to-Lock

NOTE: For this procedure, refer to FIGURE 8.3.

Converting From Push-to-Lock to Pull-to-Lock

1. Remove set screw from the lower stop position (Detail “A”).

NOTE: As the wheel lock handle is pushed downwards, the wheel lock will engage and then disengage the wheel.

2. Push wheel lock handle down to access the upper stop position (Detail “B”).
3. Install set screw into upper stop position.
4. Pull wheel lock handle up to engage wheel lock. If wheel lock does not properly engage the wheel, refer to [Adjusting the Wheel Lock](#) on page 42.

Converting From Pull-to-Lock to Push-to-Lock

1. Remove set screw from the upper stop position (Detail “B”).

NOTE: As the wheel lock handle is pulled upwards, the wheel lock will engage and then disengage the wheel.

2. Pull wheel lock handle up to access the lower stop position (Detail “A”).
3. Install set screw into lower stop position.
4. Push wheel lock handle down to engage wheel lock. If wheel lock does not properly engage the wheel, refer to [Adjusting the Wheel Lock](#) on page 42.

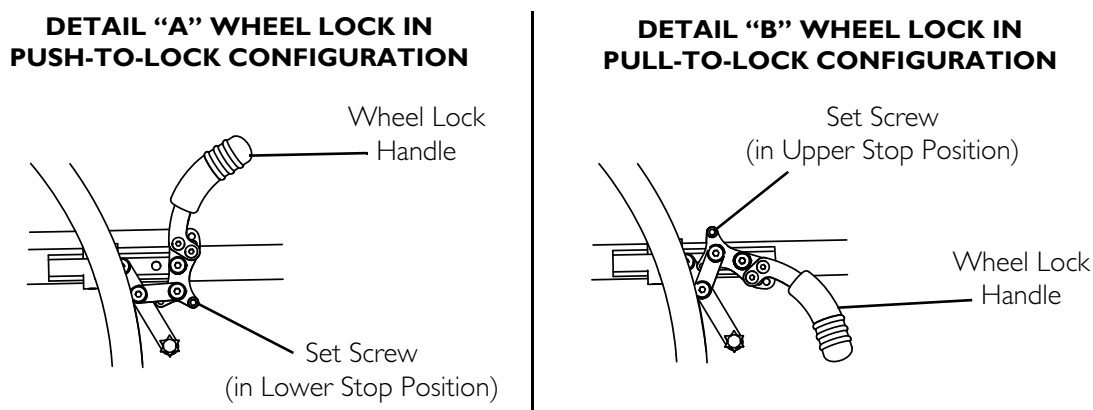

FIGURE 8.3 Converting Wheel Lock From Push-to-Lock to Pull-to-Lock or Pull-to-Lock to Push-to-Lock

SECTION 9—WHEELS

⚠ WARNING

After any adjustments, repair or service and before use, make sure all attaching hardware is tightened securely - otherwise injury or damage may result.

Removing/Installing Rear Wheels

CAUTION

Changing the size of the rear wheels can affect the performance of the wheelchair. Contact Invacare at the telephone numbers on the back of this manual before changing rear wheel size.

NOTE: For this procedure, refer to FIGURE 9.1.

1. Perform one of the following:
 - Quick-Release - Push in the tip of the quick-release axle and pull axle and wheel away from the wheelchair.
 - Quad-Release - Lift up on the handle of the quad-release axle and pull axle and wheel away from the wheelchair.
2. Repeat STEP 1 for the opposite rear wheel.
3. Reinstall the rear wheels onto the wheelchair by reversing STEPS 1-2.

⚠ WARNING

Pull on the rear wheel to make sure the detent pin and locking pins of the quick/quad-release axle are fully released before operating wheelchair.

Keep locking pins clean.

4. If there is too much movement of the rear wheel assembly in an “in and out” motion, refer to Adjusting Quick-Release Axles on page 46 or Adjusting Quad-Release Handles on page 47.

NOTE: Quad-Release Axle not shown. Locking pins on the Quad-Release Axle are the same as Quick-Release Axle.

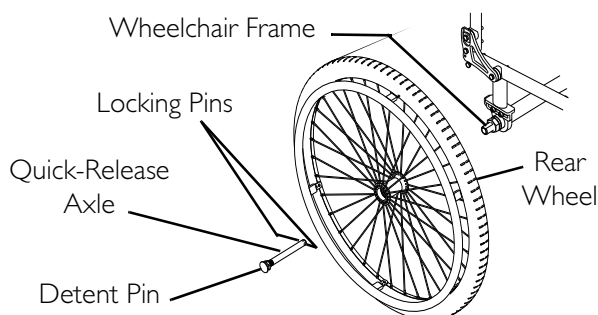

FIGURE 9.1 Removing/Installing Rear Wheels

Adjusting Quick-Release Axles

NOTE: For this procedure, refer to FIGURE 9.2.

1. Remove rear wheel and quick-release axle from the wheelchair. Refer to [Removing/Installing Rear Wheels](#) on page 45.
2. Depress detent pin in the quick-release axle and slide axle through the wheel hub.
3. Release detent pin ensuring that the locking pins are fully released.
4. Increase or decrease end play by adjusting the locknut on the end of the quick-release axle.
5. Reinstall rear wheel onto the wheelchair. Refer to [Removing/Installing Rear Wheels](#) on page 45.

NOTE: End of Quick Release axle is shown for reference only. It is not visible when inserted into camber bar.

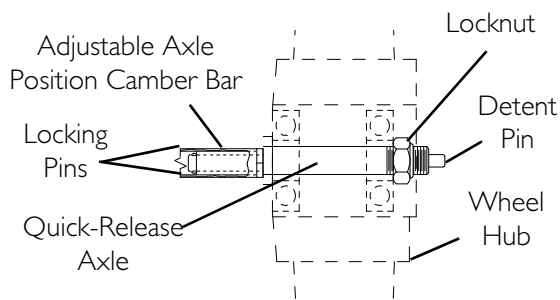

FIGURE 9.2 Adjusting Quick-Release Axles

Replacing Quad-Release Axles

NOTE: For this procedure, refer to FIGURE 9.3.

1. Remove rear wheel and the existing quick-release axle from the wheelchair. Refer to [Removing/Installing Rear Wheels](#) on page 45.
2. Remove existing quick-release axle from rear wheel.
3. Insert new quad-release axle through rear wheel hub.
4. Slide locking collar onto quad-release axle until it is snug against rear wheel and tighten securely with allen screw.
5. Reinstall rear wheel and the quad-release axle onto the wheelchair. Refer to [Removing/Installing Rear Wheels](#) on page 45.
6. Flip the handle of the quad-release axle down to release the detent pin ensuring that the locking pins are fully released.
7. If detent pin does not fully release, proceed to [Adjusting Quad-Release Handles](#) on page 47.
8. Repeat STEPS 1-7 for the opposite rear wheel.

NOTE: End of Quick Release axle is shown for reference only. It is not visible when inserted into camber bar.

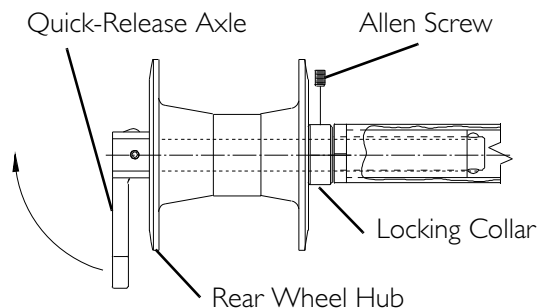

FIGURE 9.3 Replacing Quad-Release Axles

Adjusting Quad-Release Handles

NOTE: For this procedure, refer to FIGURE 9.4.

In and/or Out

1. Remove rear wheel and the quad-release axle from the wheelchair. Refer to [Removing/Installing Rear Wheels](#) on page 45.
2. Loosen the locking screw.
3. Make one or both of the following adjustments:
 - If the quad-release handle is not releasing the locking pins completely, rotate the quad-release handle approximately one-quarter turn clockwise.
 - If the quad-release handle hits the spokes of the rear wheel when assembled, rotate the quad-release handle approximately one-quarter turn counterclockwise.

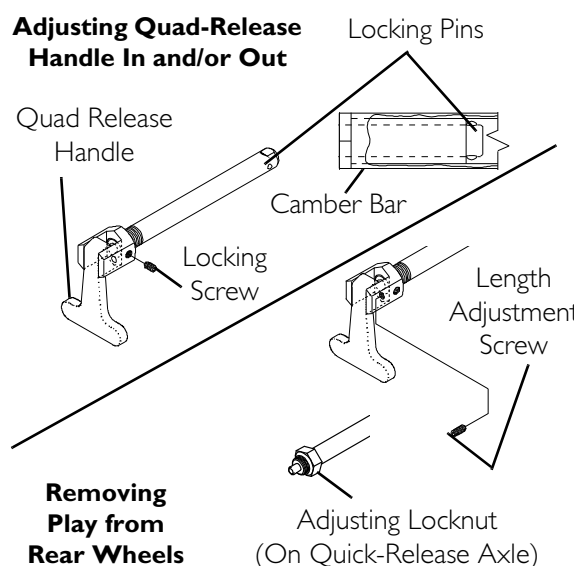

FIGURE 9.4 Adjusting Quad-Release Handles

4. Tighten the locking screw.
5. Reinstall the rear wheel and quad-release axle onto the wheelchair. Refer to [Removing/Installing Rear Wheels](#) on page 45.
6. Flip the handle of the quad-release axle down to release the detent pin ensuring that the locking pins are fully released.
7. Repeat the above procedures until the quad-release axle locks correctly.

Removing Play from Rear Wheels

1. With the rear wheel and quad-release axle still mounted onto the wheelchair, make the following adjustment:
 - Tighten the length adjusting screw until there is no in and out movement of the quad-release axle and rear wheel.

Handrim Replacement

NOTE: For this procedure, refer to FIGURE 9.5.

1. Remove the rear wheel from the wheelchair. Refer to [Removing/Installing Rear Wheels](#) on page 45.

⚠ WARNING

Tire MUST be fully deflated before any disassembly procedures are performed. Otherwise injury or damage may result.

2. Remove all air from the tube by pressing down on the pin in the center of the valve stem.
3. While carefully holding the tire, tube and rim strip to one side, hold the allen screws and remove the locknuts that secure the handrim to the rear wheel.
4. Remove the existing handrim.
5. Install new handrim by reversing STEPS 2-4.

⚠ WARNING

DO NOT inflate tire until it is completely assembled. Otherwise injury or damage may result.

6. Inflate tire to correct psi rating on the sidewall of tire.
7. Reinstall rear wheel to the wheelchair. Refer to [Removing/Installing Rear Wheels](#) on page 45.
8. Repeat STEPS 1-7 for opposite rear wheel if necessary.

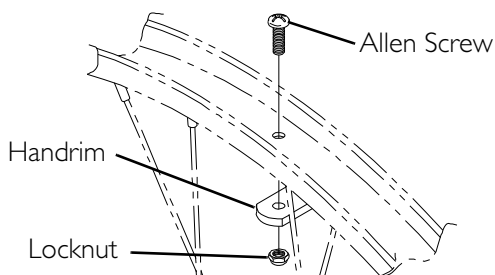

FIGURE 9.5 Handrim Replacement

Repairing/Replacing Rear Wheel, Tire/Tube

⚠ WARNING

Replacement of the tire or tube **MUST** be performed by a qualified technician.

CAUTION

Changing the size of the rear wheels can affect the performance of the wheelchair. Contact Invacare at the numbers on the back cover **BEFORE** performing this procedure.

*NOTE: If replacing rear wheels with a different size than what was originally on the wheelchair, the front caster height and/or diameter **MUST** also be changed to keep the wheelchair frame parallel to the floor. Refer to Removing/Installing/Repositioning the Caster Assemblies on page 58 **ONLY** after contacting Invacare. Anti-tipper height (if applicable) **MUST** also be adjusted to maintain 1-1/2 to 2-inch clearance between bottom of the anti-tipper wheels and the floor. Refer to Adjusting/Replacing Anti-tipper on page 62.*

Adjusting Wheelbase Length, Adjusting Center of Gravity (COG)

⚠ WARNING

ALWAYS perform this procedure in the presence of an assistant. The position of the footrest, camber tube, seat angle, back angle, the tautness of the back upholstery as well as the user's condition are directly related to the wheelchairs stability. Any change to one or any combination of the six may cause the wheelchair to decrease in stability. Use **EXTREME** caution when using a new seating position. The addition of anti-tippers may be required.

NOTE: For this procedure, refer to FIGURE 9.6 on page 50.

NOTE: Measure the distance between the center of the front caster and the center of the rear wheel to determine the new wheelbase length.

NOTE: The wheelbase length can be adjusted in one or more of the following combinations:

- Repositioning the camber tube clamps.
 - Repositioning the camber tube clamps socket screws.
 - Reversing the camber tube clamps direction
1. Refer to the chart below to determine the adjustments necessary to achieve the desired wheelbase length.

WHEELS

CAUTION

Ensure one empty mounting position remains between the two socket screws, otherwise damage to the wheelchair may occur.

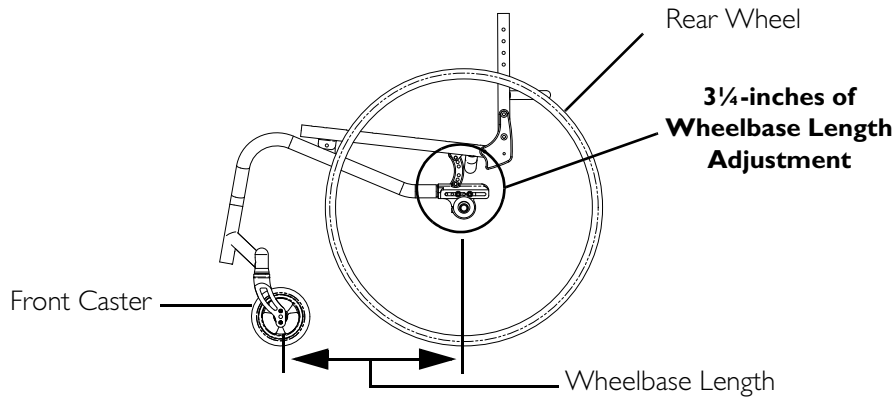

SOCKET SCREW MOUNTING POSITIONS

CAMBER TUBE CLAMP FACING THE FRONT OF THE WHEELCHAIR	CAMBER TUBE CLAMP FACING THE REAR OF THE WHEELCHAIR
<p><i>NOTE: Camber tube clamp shown in forward most position.</i></p> <p>← Front of Wheelchair</p> 	<p><i>NOTE: Camber tube clamp shown in rear most position.</i></p> <p>Rear of Wheelchair →</p> 
 <p>Mounting Positions</p> <p>Socket Screws</p>	 <p>Socket Screws</p> <p>Mounting Positions</p>
 <p>Mounting Positions</p> <p>Socket Screws</p>	 <p>Socket Screws</p> <p>Mounting Positions</p>
 <p>Mounting Positions</p> <p>Socket Screws</p>	 <p>Socket Screws</p> <p>Mounting Positions</p>

FIGURE 9.6 Adjusting Wheelbase Length, Adjusting Center of Gravity (COG)

Repositioning the Camber Tube Clamps

NOTE: For this procedure, refer to FIGURE 9.7.

1. Remove the rear wheels. Refer to Removing/Installing Rear Wheels on page 45.
2. Loosen, but DO NOT remove, the four socket screws and washers that secure the two camber tube clamps to the camber tube supports.
3. Slide the camber tube forward or backward to adjust the wheelbase length to the desired position.

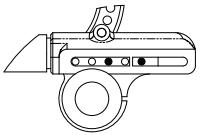
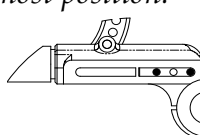
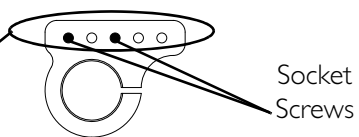
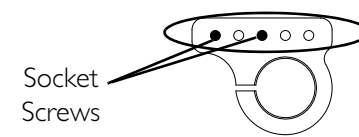
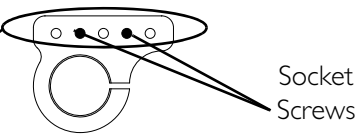
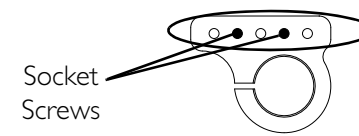
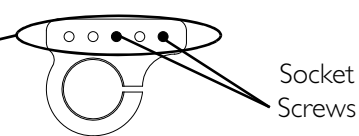
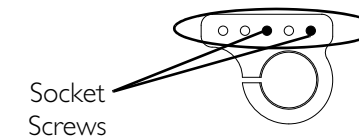
NOTE: Ensure that both camber tube clamps are adjust to the same position in the camber tube support. This will ensure that the camber tube remains at 90° to each side frame.

4. Securely tighten the four socket screws and washers that secure the two camber tube clamps to the camber tube supports.
5. Install the rear wheels. Refer to Removing/Installing Rear Wheels on page 45.

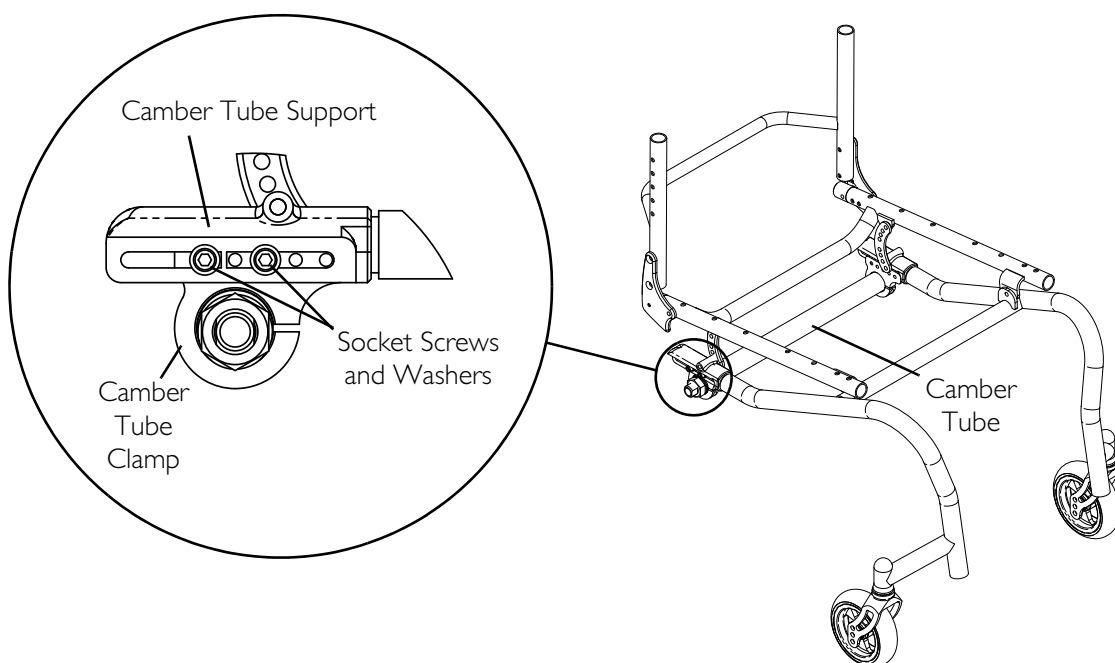

FIGURE 9.7 Repositioning the Camber Tube Clamps

Repositioning the Camber Tube Clamp Socket Screws

NOTE: For this procedure, refer to FIGURE 9.8 on page 52.

1. Remove the rear wheels. Refer to Removing/Installing Rear Wheels on page 45.
2. Refer to Socket Screw Mounting Positions in FIGURE 9.6 to determine which socket screw(s) MUST be moved and to which mounting positions.
3. Remove the four socket screws and washers from both camber tube clamps.

WHEELS

4. Align the desired mounting positions of the camber tube clamps with the opening of the camber tube supports.

CAUTION

Ensure one empty mounting position remains between the two socket screws, otherwise damage to the wheelchair may occur.

5. Install the four socket screws and washers into the desired mounting positions of both camber tube clamps. Hand tighten.

NOTE: Ensure that both camber tube clamps are adjust to the same position in the camber tube support. This will ensure that the camber tube remains at 90° to each side frame.

6. Slide the camber tube forward or backward to adjust the wheelbase length to the desired position. Securely tighten the four socket screws.
7. Install the rear wheels. Refer to Removing/Installing Rear Wheels on page 45.

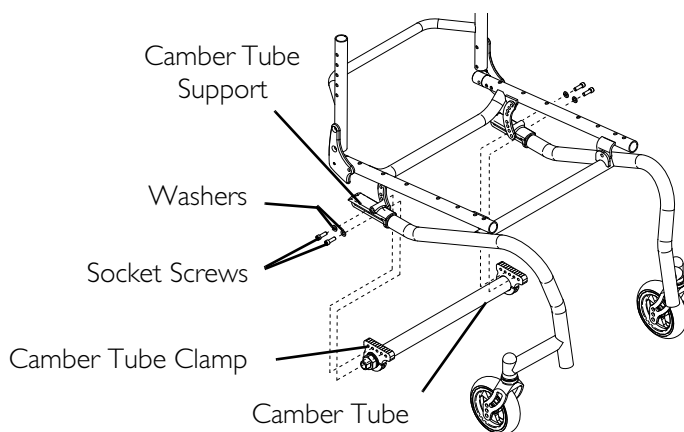

FIGURE 9.8 Repositioning the Camber Tube Clamp Socket Screws

Reversing the Camber Tube Clamp Direction

NOTE: For this procedure, refer to FIGURE 9.9 on page 53.

1. Remove the rear wheels. Refer to Removing/Installing Rear Wheels on page 45.
2. Remove the four socket screws and washers that secure the two camber tube clamps to the camber tube supports.
3. Rotate the camber tube so that the camber tube clamps face the opposite direction.
4. Align the desired mounting positions of the camber tube clamps with the opening of the camber tube supports.

CAUTION

Ensure one empty mounting position remains between the two socket screws, otherwise damage to the wheelchair may occur.

5. Install the four socket screws and washers into the desired mounting positions of both camber tube clamps. Hand tighten.

NOTE: Ensure that both camber tube clamps are adjust to the same position in the camber tube support. This will ensure that the camber tube remains at 90° to each side frame.

6. Slide the camber tube forward or backward to adjust the wheelbase length to the desired position. Securely tighten the four socket screws.
7. Install the rear wheels. Refer to Removing/Installing Rear Wheels on page 45.

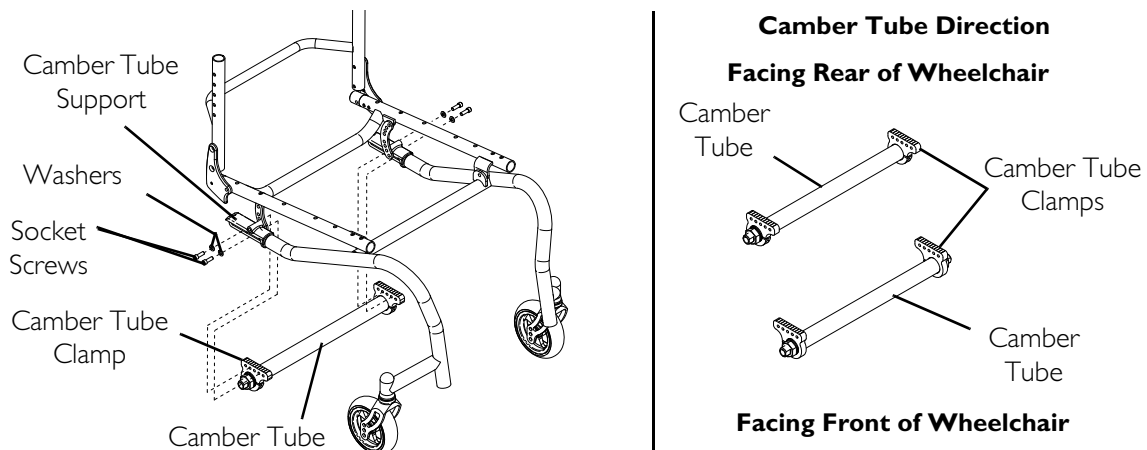

FIGURE 9.9 Reversing the Camber Tube Clamp Direction

Adjusting Wheelbase Width

NOTE: For this procedure, refer to FIGURE 9.10.

NOTE: Perform this procedure on one side of the wheelchair at a time for ease of adjustment.

NOTE: The wheelbase width can be increased/decreased by 1-inch.

1. Remove the rear wheels. Refer to Removing/Installing Rear Wheels on page 45.
2. Loosen the axle nut and rotate axle busing to increase/decrease the wheelbase width.
3. Securely tighten axle nut.
4. Count the number of threads showing on the axle bushing.

NOTE: The number of threads showing on the axle bushing should be equal on both sides of the wheelchair. Otherwise, wheelchair performance may be affected.

5. Repeat STEPS 2-3 for the opposite axle bushing.
6. Install the rear wheels. Refer to Removing/Installing Rear Wheels on page 45

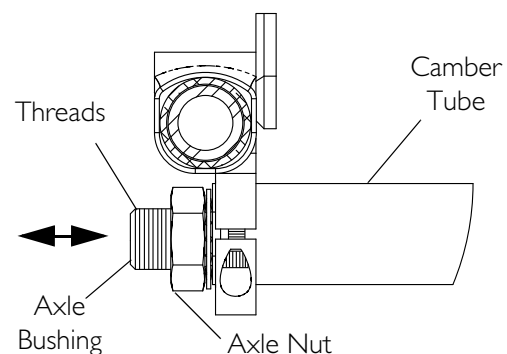

FIGURE 9.10 Adjusting Wheelbase Width

Removing/Installing the Camber Tube

⚠ WARNING

Camber tube clamps - Make sure the clamp screws are securely tightened before using the wheelchair, otherwise personal injury or damage to the wheelchair may occur.

NOTE: For this procedure, refer to FIGURE 9.11.

Removing the Camber Tube

1. Remove the rear wheels. Refer to Removing/Installing Rear Wheels on page 45.
2. Loosen the two socket head clamp screws securing camber tube to the two camber tube clamps.
3. Slide the camber tube through the camber tube clamps.

Installing the Camber Tube

1. Insert the camber tube into the camber tube clamps.
2. Center the camber tube in the camber tube clamps.
3. Adjust the camber tube. Refer to Adjusting the Camber Tube on page 55.

NOTE: There are four types of camber tubes: 0°, 3°, 6° and 9°. If the camber tube being used is 3°, 6° or 9° degrees, then the camber tube MUST be rotated so that the axle bushings at the ends of camber tube are angled up (Detail "A"). Installing the camber tube in any other orientation will directly impact the angle of the rear wheel.

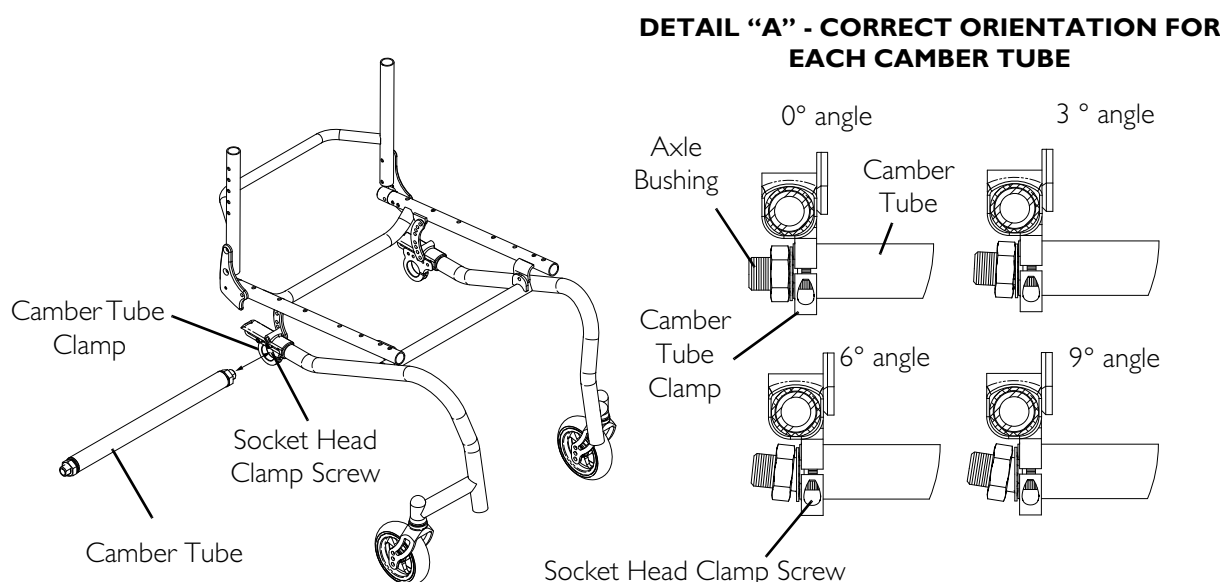

FIGURE 9.11 Adjusting Wheelbase Length, Adjusting Center of Gravity (COG)

Adjusting the Camber Tube

⚠ WARNING

Camber tube clamps - Make sure the clamp screws are securely tightened before using the wheelchair, otherwise injury or damage to the wheelchair may occur.

NOTE: For this procedure, refer to FIGURE 9.12.

Stand behind the wheelchair to determine left or right.

1. Loosen, but DO NOT remove, the socket head clamp screws in the camber tube clamps (Detail "A").
2. Using an "L" square, rotate the axle tube until the flat edge of the camber tube is at a 90° angle with the ground/floor.

NOTE: Ensure camber tube is centered between clamps.

NOTE: This adjustment is made with the rear wheels attached to the chair and all four wheels contacting the floor.

NOTE: If camber tube is not 0° degrees, then it MUST be rotated so that the axle bushings are angled up at their ends (FIGURE 9.12).

3. Securely tighten the socket screw in the camber tube clamps (Detail "A").
4. Determine the toe in/toe out of the wheelchair. Refer to [Determining/Setting Toe In/Toe Out](#) on page 56.

DETAIL "A" - SIDE VIEW

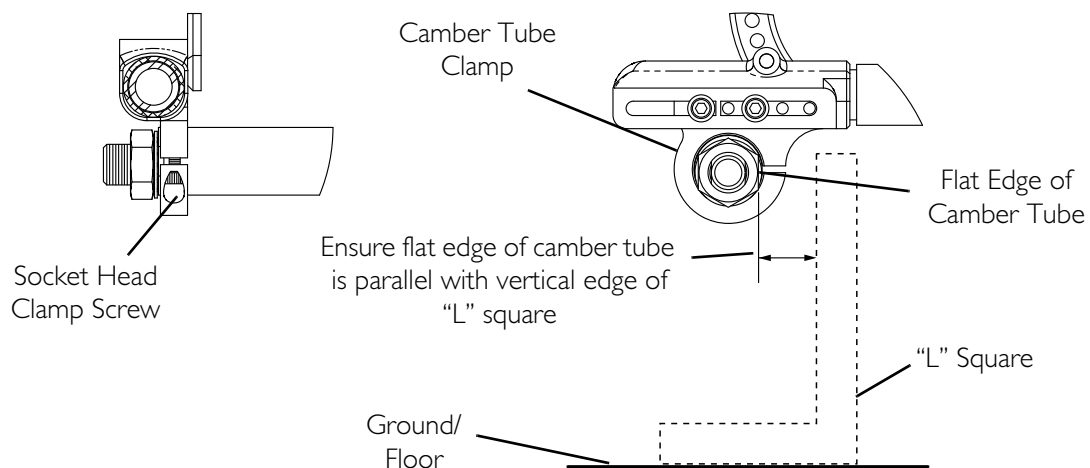

FIGURE 9.12 Adjusting the Camber Tube

Determining/Setting Toe In/Toe Out

NOTE: For this procedure, refer to FIGURE 9.11 on page 54 and FIGURE 9.13.

1. Inflate all pneumatic tires to recommended tire pressures (listed on the sidewall of the tire).
2. Measure the distance between the centerlines at the rear and front of the rear wheels at approximately 12 inches (for 24-inch diameter wheels) from the ground/floor (FIGURE 9.13).
3. Determine difference between two measurements. If difference between the two measurements is greater than $\frac{1}{8}$ inch, one of two conditions exists:
 - If the back centerline measurement of the rear wheels is SMALLER than the front centerline measurement of the rear wheels, a TOE-OUT condition exists (FIGURE 9.13).
 - If the back centerline measurement of the rear wheels is LARGER than the front centerline measurement of the rear wheels, a TOE-IN condition exists (FIGURE 9.13).
4. If the difference between the measurements is greater than $\frac{1}{8}$ -inch, correct the toe-in/toe-out condition by performing the following:
 - A. Loosen both mounting socket head clamp screws (FIGURE 9.11).
 - B. Rotate the camber tube until front and rear measurement are within $\frac{1}{8}$ -inch (FIGURE 9.11).
 - C. Securely tighten both socket head clamp screws (FIGURE 9.11).

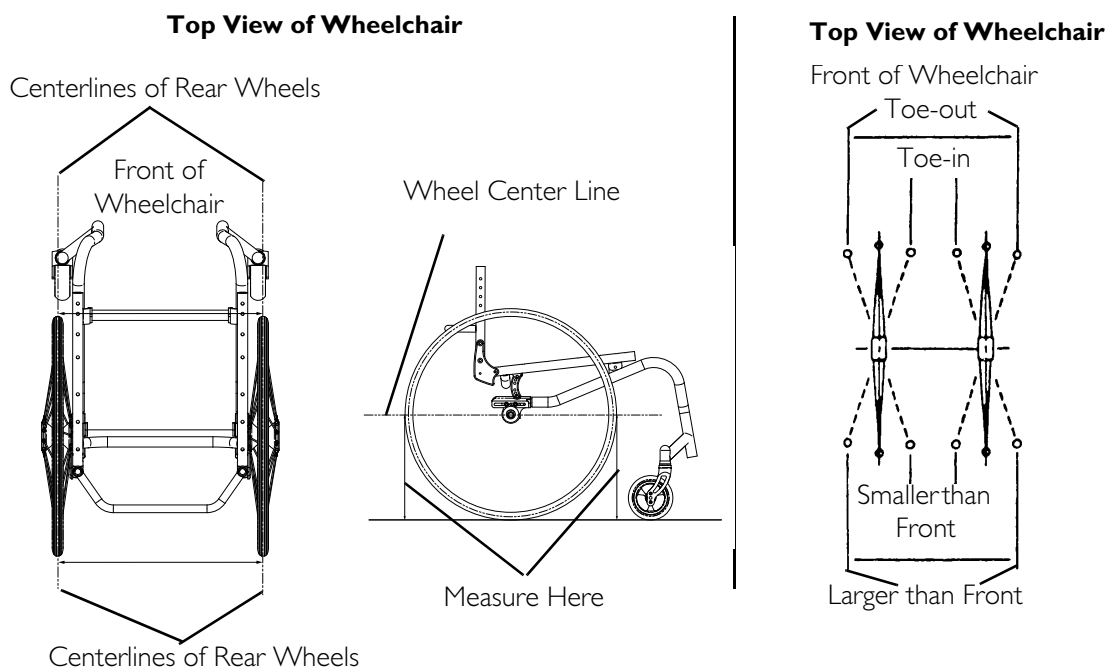

FIGURE 9.13 Determining/Setting Toe In/Toe Out

Adjusting Fork Tension

NOTE: For this procedure, refer to FIGURE 9.14.

1. To properly tighten forks and guard against flutter, perform the following check on both forks:
 - A. Tip back the wheelchair to floor.
 - B. Pivot both forks and casters to top of their arc simultaneously.
 - C. Let casters drop to bottom of arc (wheels should swing once to one-side, then IMMEDIATELY rest in a straight downward position).
2. If necessary, perform one of the following to adjust the fork tension:
 - Standard Forks - Adjust locknut according to freedom of caster swing (Detail "A").
 - a. Tighten locknut to reduce caster swing.
 - b. Loosen the locknut to increase caster swing.
 - Suspension Fork (Detail "B") -
 - a. Refer to Removing the Elastomer on page 61 to remove the elastomer and suspension fork bottom to access the locknut.
 - b. Adjust locknut according to freedom of caster swing.
 - c. Refer to Installing the Elastomer on page 61 to secure the suspension fork top to the elastomer and suspension fork bottom.
3. Test wheelchair for maneuverability.
4. If necessary, repeat STEPS 1-2 to adjust locknuts until tension is correct for both forks.

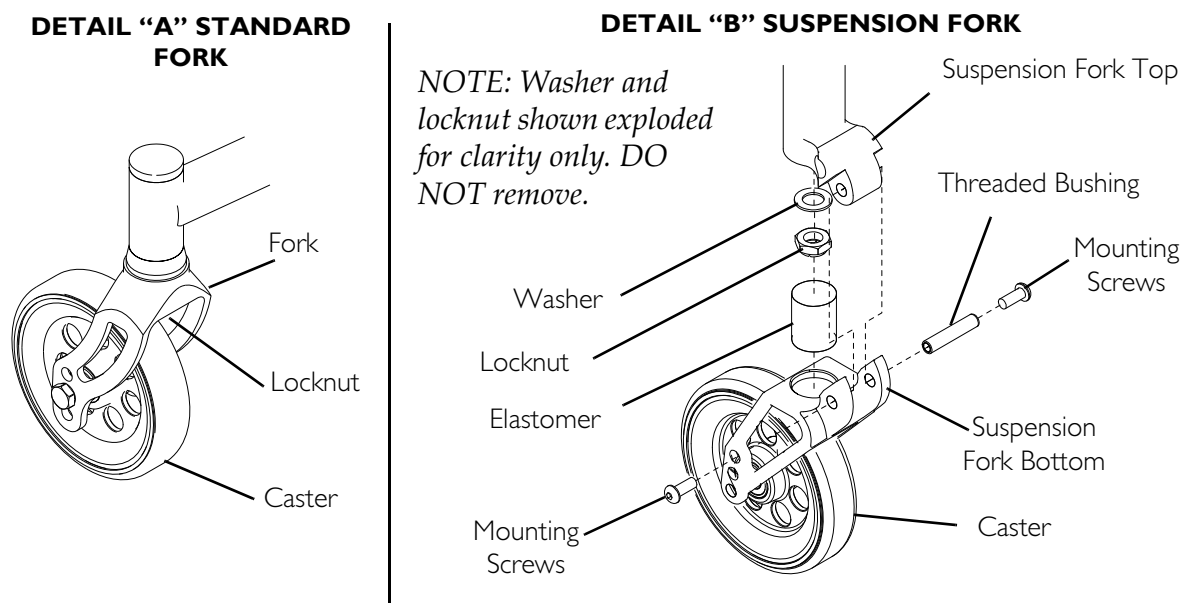

FIGURE 9.14 Adjusting Fork Tension

Removing/Installing/Repositioning the Caster Assemblies

NOTE: If replacing a front caster note the mounting position of the existing front caster for installation of the new front caster.

NOTE: Both front casters MUST be the same size and adjusted to the same height.

Standard Forks

NOTE: For this procedure, refer to FIGURE 9.15.

Removing Front Caster

1. Remove the mounting bolt, axle spacers and locknut that secure the front caster to the fork.
2. Remove the caster from the fork.

Installing Front Caster

1. Using the mounting bolt, axle spacers and locknut, secure the caster to the desired caster mounting position.

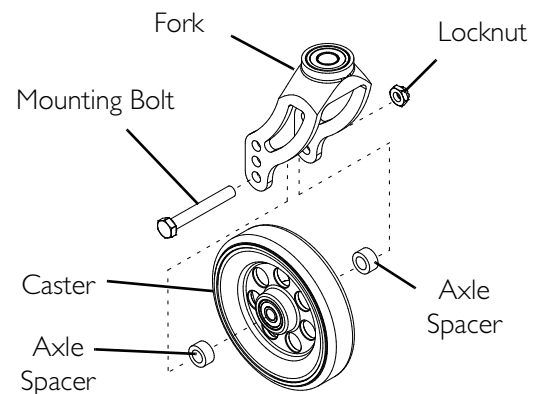

FIGURE 9.15 Removing/Installing/Repositioning the Caster Assemblies - Standard Forks

Suspension Forks

NOTE: For this procedure, refer to FIGURE 9.16 on page 59.

Removing the Caster

NOTE: One mounting screw will not turn.

1. Using two allen wrenches, turn mounting screws in opposite directions and remove one mounting screw from fork.
2. Remove the threaded bushing with mounting screw and two spacers securing the caster to the fork. DO NOT use excessive force.
3. Remove the caster from the fork.

Installing the Caster

1. Align the caster with the desired mounting holes in the fork.
2. Insert the threaded bushing with mounting screw, through the two axle spacers and caster. DO NOT use excessive force.

⚠ WARNING

Use Loctite™ 242 when reinstalling the mounting screw into the threaded bushing. Otherwise the fork can become disassembled. Possible injury or damage could result.

3. Apply Loctite 242 to the mounting screw.
4. Reinstall the mounting screw into the threaded bushing and tighten securely.

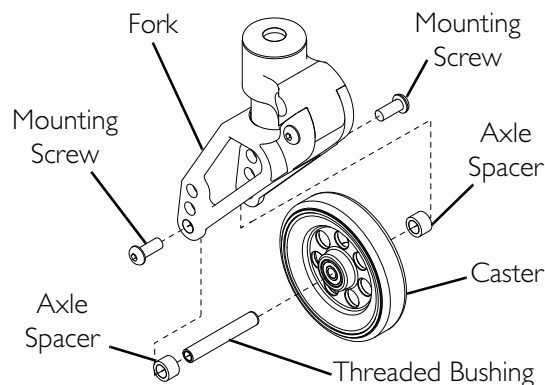

FIGURE 9.16 Removing/Installing/Repositioning the Caster Assemblies - Suspension Forks

Removing/Installing the Fork Assembly

NOTE: For this procedure, refer to FIGURE 9.17 on page 60.

NOTE: If replacing a fork, note the mounting position of the existing front caster for installation of the new fork.

Removing Fork Assembly

1. Remove the front caster from the fork. Refer to Removing Front Caster on page 58.
2. Perform one of the following:
 - Standard Forks - Remove locknut securing the fork from the fork stem (Detail "A").
 - Suspension Fork (Detail "B") -
 - a. Refer to Removing the Elastomer on page 61 to remove the elastomer and suspension fork bottom to access the locknut.
 - b. Remove locknut securing the suspension fork top from the fork stem.

Installing Fork Assembly

1. Perform one of the following:
 - Standard Forks - Using a locknut, secure the fork to the fork stem (Detail "A").
 - Suspension Fork (Detail "B") -
 - a. Using a locknut, secure the suspension fork top to the fork stem.
 - b. Refer to Installing the Elastomer on page 61 secure the suspension fork top to the elastomer and suspension fork bottom.
2. Install the front caster. Refer to Installing Front Caster on page 58.

DETAIL "A" STANDARD FORK

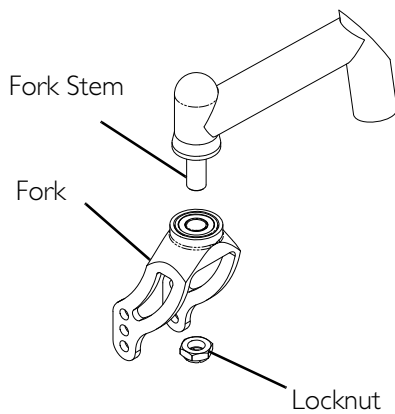

DETAIL "B" SUSPENSION FORK

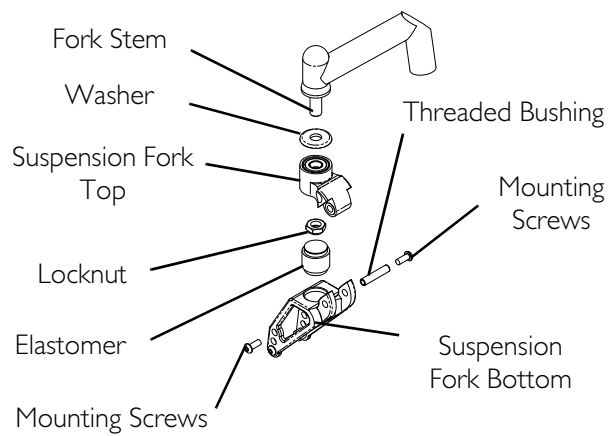

FIGURE 9.17 Removing/Installing the Fork Assembly

Removing/Installing the Elastomers (Suspension Forks Only)

CAUTION

DO NOT use excessive force when removing/installing the threaded sleeve from/onto the fork. **Damage to the threaded sleeve may occur.**

NOTE: For this procedure, refer to FIGURE 9.18.

Removing the Elastomer

NOTE: One mounting screw will not turn.

1. Using two allen wrenches, turn mounting screws in opposite directions and remove one mounting screw from fork.
2. Remove the threaded bushing and mounting screw securing the suspension fork top to the elastomer and the suspension fork bottom. **DO NOT** use excessive force.
3. If replacing the elastomer, discard the existing elastomer.

Installing the Elastomer

NOTE: Make sure the elastomer sits in the two recessed areas on the fork.

1. Position the new elastomer between the suspension fork top and suspension fork bottom.
2. Align the mounting holes in the suspension fork top and suspension fork bottom.
3. Using the threaded bushing and mounting screw, secure the suspension fork top and suspension fork bottom. **DO NOT** use excessive force.

⚠ WARNING

Use Loctite 242 when reinstalling the mounting screw into the threaded bushing. Otherwise the fork can become disassembled. Possible injury or damage could result.

4. Apply Loctite 242 to the mounting screw.
5. Reinstall the mounting screw into the threaded bushing and tighten securely.

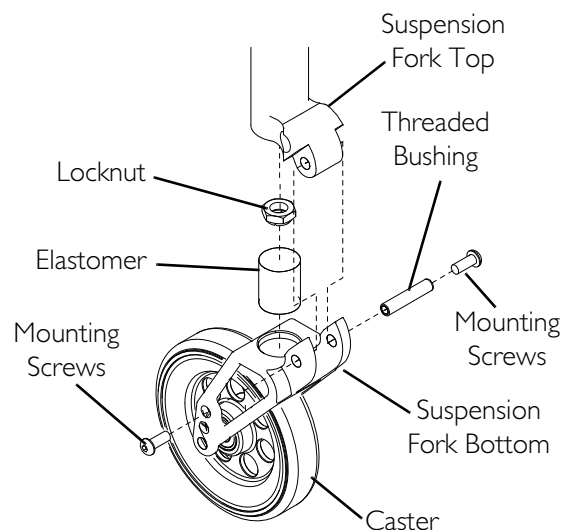

FIGURE 9.18 Removing/Installing the Elastomers (Suspension Forks Only)

SECTION 10—ANTI-TIPPER

⚠ WARNING

After **ANY** adjustments, repair or service and **BEFORE** use, make sure all attaching hardware is tightened securely - otherwise injury or damage may occur.

Adjusting/Replacing Anti-tipper

⚠ WARNING

Anti-tippers **MUST** be attached at all times. Inasmuch as the anti-tippers are an option on this wheelchair (you may order it with or without the anti-tippers), Invacare strongly recommends ordering the anti-tippers as an additional safeguard for the wheelchair user.

Anti-tippers **MUST** be fully engaged. Ensure the lock buttons of the anti-tippers fully protrudes out of the mounting hole in the anti-tipper bracket.

Ensure both anti-tippers are adjusted to the same height.

NOTE: For this procedure, refer to FIGURE 10.1 on page 64.

NOTE: To ensure the correct model anti-tipper is used refer to FIGURE 10.1. Measurements for anti-tippers are approximate and are taken using the top adjustment hole on the anti-tipper (Detail "A").

Adjusting Anti-tipper

⚠ WARNING

When anti-tippers are used, anti-tippers **MUST** be adjusted to maintain a 1-1/2 to 2-inch clearance between the bottom of the anti-tipper wheels and the ground/floor. This spacing should **ALWAYS** be checked whenever adjustments/changes are made to the wheelchair. Failure to maintain proper spacing may result in the chair tipping over backward causing serious injury or property damage.

1. Press in the lock button that secures the anti-tipper wheel assembly to the anti-tipper bar.
2. Adjust the height of the anti-tipper wheels to between 1-1/2 and 2-inches of the ground/floor.
3. Repeat STEPS 1-2 for the opposite anti-tipper.

Replacing Anti-tipper

⚠ WARNING

When anti-tippers are used, anti-tippers MUST be adjusted to maintain a 1-1/2 to 2-inch clearance between the bottom of the anti-tipper wheels and the ground/floor. This spacing should ALWAYS be checked whenever adjustments/changes are made to the wheelchair. Failure to maintain proper spacing may result in the chair tipping over backward causing serious injury or property damage.

1. Press in the release button that secures the existing anti-tipper to the anti-tipper bracket and remove the anti-tipper from the anti-tipper bracket.
2. Insert the new anti-tipper into the anti-tipper bracket until lock buttons protrude out of mounting hole.
3. Press in the lock button on the anti-tipper bar and install the anti-tipper wheels onto the new anti-tipper bar.
4. Repeat STEPS 1-3 for the opposite anti-tipper.
5. Measure the distance between the bottom of the anti-tipper wheels and the ground floor.
6. If necessary, adjust the height of the anti-tippers. Refer to [Adjusting Anti-tipper](#) on page 62.

DETAIL "A" - ANTI-TIPPER ADJUSTMENT HOLES

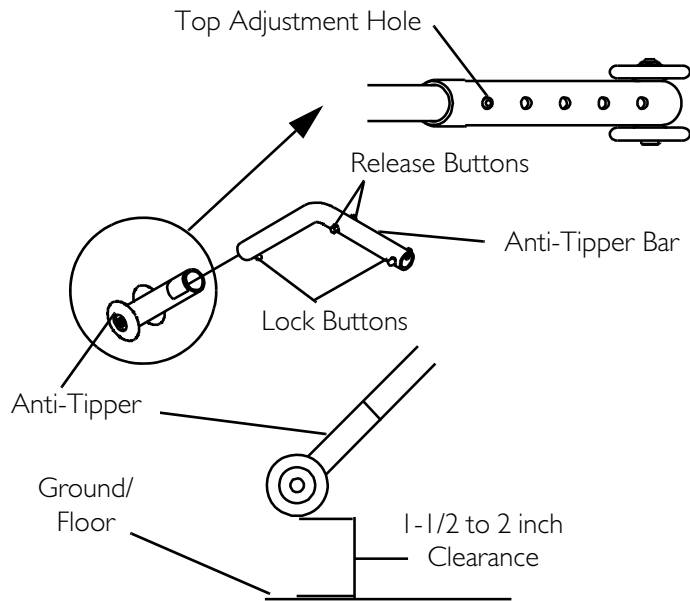

ANTI-TIPPERS USED WITH HIGH SEAT TO FLOOR HEIGHTS

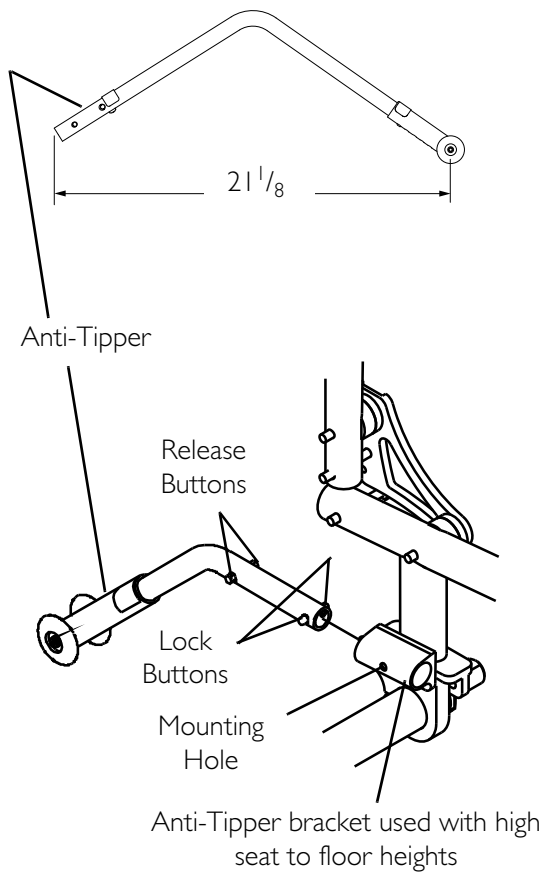

ANTI-TIPPERS USED WITH LOW SEAT TO FLOOR HEIGHTS

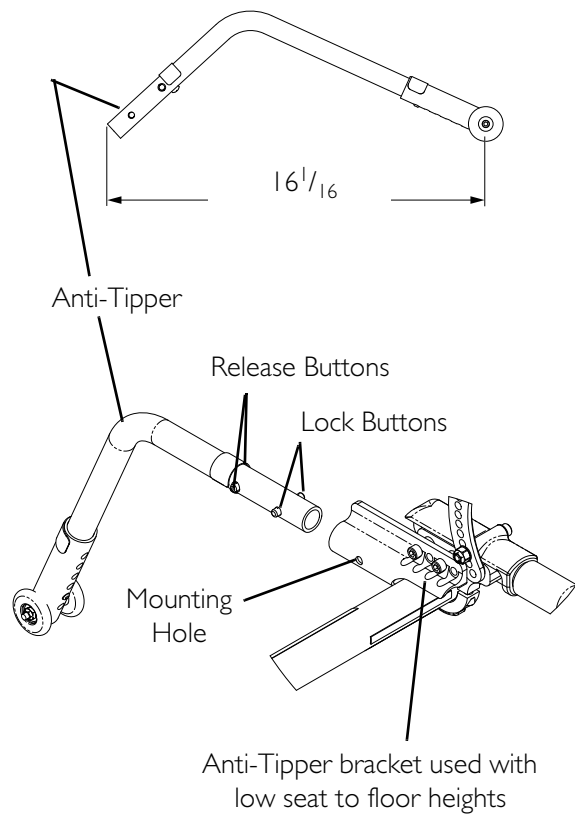

FIGURE 10.1 Adjusting/Replacing Anti-tipper

NOTES

NOTES

LIMITED WARRANTY

PLEASE NOTE: THE WARRANTY BELOW HAS BEEN DRAFTED TO COMPLY WITH FEDERAL LAW APPLICABLE TO PRODUCTS MANUFACTURED AFTER JULY 4, 1975.

This warranty is extended only to the original purchaser/user of our products.

This warranty gives you specific legal rights and you may also have other legal rights which vary from state to state.

Invacare warrants the Crossfire frame to be free from defects in materials and workmanship for the original purchaser for the 5 years from the date of purchase. All component parts including, but not limited to folding back, camber tubes, caster forks are warranted against defects in materials and workmanship for a period of one year from the date of purchase except armrests and upholstery, push handle grips, bushings, bearings, and tires/tubes. If within such warranty period any such product shall be proven to be defective, such product shall be repaired or replaced, at Invacare's option. This warranty does not include any labor or shipping charges incurred in replacement part installation or repair of any such product. Invacare's sole obligation and your exclusive remedy under this warranty shall be limited to such repair and/or replacement.

For warranty service, please contact the dealer from whom you purchased your Invacare product. In the event you **DO NOT** receive satisfactory warranty service, please write directly to Invacare at the address on the back page. Provide dealer's name, address, date of purchase, indicate nature of the defect and, if the product is serialized, indicate the serial number. **DO NOT** return products to our factory without our prior consent.

LIMITATIONS AND EXCLUSIONS: THE FOREGOING WARRANTY SHALL NOT APPLY TO SERIAL NUMBERED PRODUCTS IF THE SERIAL NUMBER HAS BEEN REMOVED OR DEFACED, PRODUCTS SUBJECTED TO NEGLIGENCE, ACCIDENT, IMPROPER OPERATION, MAINTENANCE OR STORAGE, COMMERCIAL OR INSTITUTIONAL USE, PRODUCTS MODIFIED WITHOUT INVACARE'S EXPRESS WRITTEN CONSENT, INCLUDING, BUT NOT LIMITED TO, MODIFICATION THROUGH THE USE OF UNAUTHORIZED PARTS OR ATTACHMENTS; PRODUCTS DAMAGED BY REASON OF REPAIRS MADE TO ANY COMPONENT WITHOUT THE SPECIFIC CONSENT OF INVACARE, OR TO A PRODUCT DAMAGED BY CIRCUMSTANCES BEYOND INVACARE'S CONTROL, AND SUCH EVALUATION WILL BE SOLELY DETERMINED BY INVACARE. THE WARRANTY SHALL NOT APPLY TO PROBLEMS ARISING FROM NORMAL WEAR OR FAILURE TO ADHERE TO THESE INSTRUCTIONS.

THE FOREGOING EXPRESS WARRANTY IS EXCLUSIVE AND IN LIEU OF ANY OTHER WARRANTIES WHATSOEVER, WHETHER EXPRESS OR IMPLIED, INCLUDING THE IMPLIED WARRANTIES OF MERCHANTABILITY AND FITNESS FOR A PARTICULAR PURPOSE, AND THE SOLE REMEDY FOR VIOLATIONS OF ANY WARRANTY WHATSOEVER, SHALL BE LIMITED TO REPAIR OR REPLACEMENT OF THE DEFECTIVE PRODUCT PURSUANT TO THE TERMS CONTAINED HEREIN. THE APPLICATION OF ANY IMPLIED WARRANTY WHATSOEVER SHALL NOT EXTEND BEYOND THE DURATION OF THE EXPRESS WARRANTY PROVIDED HEREIN. THE MANUFACTURER SHALL NOT BE LIABLE FOR ANY CONSEQUENTIAL OR INCIDENTAL DAMAGES WHATSOEVER.

THIS WARRANTY SHALL BE EXTENDED TO COMPLY WITH STATE/PROVINCIAL LAWS AND REQUIREMENTS.



Yes, you can.[®]

Invacare Corporation www.invacare.com

USA

One Invacare Way
Elyria, Ohio USA
44036-2125
800-333-6900

Canada

570 Matheson Blvd E Unit 8
Mississauga Ontario
L4Z 4G4 Canada
800-668-5324

All rights reserved. Trademarks are identified by the symbols [™] and [®]. All trademarks are owned by or licensed to Invacare Corporation unless otherwise noted.

Natural Fit is a registered trademark of Three Rivers.

Spinergy is a registered trademark of Spinergy, Inc.

3-in-1 oil is a registered trademark of American Home Products Corporation.

WD-40 is a registered trademark of WD-40 Company.

Loctite 242 is a trademark of the Loctite Corporation.

Teflon is a registered trademark of E.I. Du Pont De Nemours and Company.

Schwalbe is a registered trademark of Ralf Bohle GmbH & Co. KG Corporation, Germany.

© 2008 Invacare Corporation.

Part No 1134343

Rev A - 8/08