

## Owner's Operator and Maintenance Manual

# **Pronto<sup>®</sup> M41 with SureStep<sup>®</sup>**

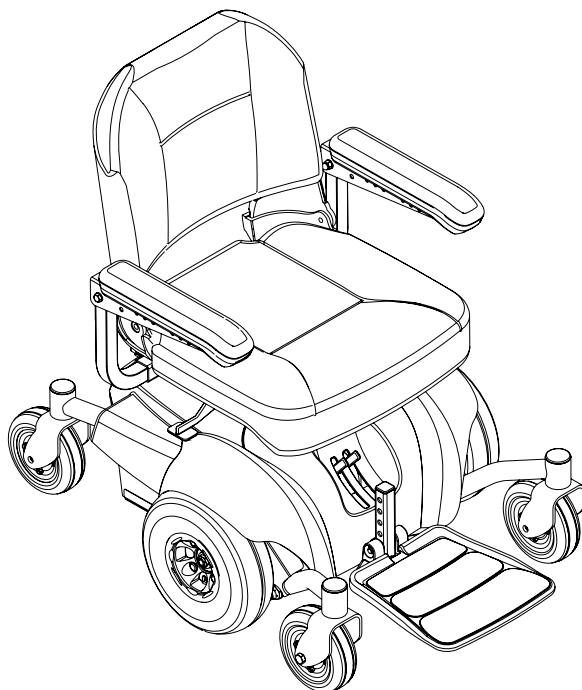

**DEALER:** This manual **MUST** be given to the user of the wheelchair.

**USER:** BEFORE using this wheelchair, read this manual and save for future reference.

For more information regarding  
Invacare products, parts, and services,  
please visit [www.invacare.com](http://www.invacare.com)



**Yes, you can.<sup>®</sup>**

---

## **WARNING**

**A qualified technician MUST perform the initial set up of this wheelchair. Also, a qualified technician MUST perform all procedures in the service manual.**

**DO NOT use this product or any available optional equipment without first completely reading and understanding these instructions and any additional instructional material such as owner's manuals, service manuals or instruction sheets supplied with this product or optional equipment. If you are unable to understand the warnings, cautions or instructions, contact a healthcare professional, dealer or technical personnel before attempting to use this equipment - otherwise, injury or damage may occur.**

---

## **ACCESSORIES WARNING**

**Invacare products are specifically designed and manufactured for use in conjunction with Invacare accessories. Accessories designed by other manufacturers have not been tested by Invacare and are not recommended for use with Invacare products.**

---

# REFERENCE DOCUMENTS

DOCUMENT	PART NUMBER
Pronto M4I with SureStep Service Manual	1145724
MK <sub>5</sub> <sup>™</sup> SPJ <sup>™</sup> -INT Electronics Manual	1148096

*NOTE: Updated versions of this manual are available on [www.invacare.com](http://www.invacare.com).*

# TABLE OF CONTENTS

<b>REFERENCE DOCUMENTS .....</b>	<b>2</b>
<b>SPECIAL NOTES .....</b>	<b>6</b>
<b>LABEL LOCATION .....</b>	<b>8</b>
<b>TYPICAL PRODUCT PARAMETERS .....</b>	<b>9</b>
<b>SECTION 1—GENERAL GUIDELINES .....</b>	<b>11</b>
Controller Settings/Repair or Service .....	11
Accessories Information .....	11
Operation Information .....	11
Batteries.....	13
Grounding Instructions .....	14
Rain Test.....	14
Weight Training .....	14
Weight Limitation.....	14
<b>SECTION 2—EMI INFORMATION .....</b>	<b>15</b>
<b>SECTION 3—INITIAL SETUP .....</b>	<b>17</b>
Setup Checklist .....	17
<b>SECTION 4—SAFETY/HANDLING OF WHEELCHAIRS .....</b>	<b>18</b>
Stability and Balance.....	18
Coping With Everyday Obstacles .....	19
A Note to Wheelchair Assistants .....	19
Pinch Points.....	20
Lifting/Stairways .....	20
Transferring To and From Other Seats .....	22
Reaching, Leaning and Bending - Forward .....	23
Reaching and Bending - Backward .....	23
<b>SECTION 5—SAFETY INSPECTION .....</b>	<b>24</b>
Safety Inspection Checklists.....	24
Troubleshooting Guide .....	26
Troubleshooting - Electrical.....	27
<b>SECTION 6—WHEELCHAIR OPERATION .....</b>	<b>29</b>
Turning the Power On/Off.....	29
Using the Joystick to Drive the Wheelchair .....	30
MK5 SPJ-INT Joystick Switches and Indicators .....	31

# TABLE OF CONTENTS

<b>SECTION 7—ARMS .....</b>	<b>34</b>
Removing/Installing the Arms .....	34
Adjusting the Arms .....	35
<b>SECTION 8—SEAT .....</b>	<b>37</b>
Removing/Installing the Seat Assembly.....	37
Adjusting the Back Angle (Semi-Recline Back) .....	38
Adjusting the Headrest .....	38
Replacing the Seat Positioning Strap .....	39
<b>SECTION 9—FOOTBOARD ASSEMBLY .....</b>	<b>40</b>
Removing/Installing the Footboard Assembly.....	40
Adjusting the Footboard Assembly .....	41
<b>SECTION 10—FRONT RIGGINGS .....</b>	<b>44</b>
Installing/Removing Front Riggings .....	44
Adjusting Footrest Height .....	45
Replacing Heel Loops .....	46
Raising/Lowering Elevating Front Riggings .....	47
Adjusting/Replacing Telescoping Front Rigging Supports.....	47
<b>SECTION 11—SHROUD AND WHEELS .....</b>	<b>49</b>
Replacing the Flat Free Tires on the Wheel Rim.....	49
Removing/Installing the Top Shroud .....	49
Removing/Installing the Rear Shroud .....	50
Engaging/Disengaging Motor Release Lever .....	51
Removing/Installing Casters .....	51
Adjusting Forks .....	52
Removing/Installing Forks and/or Caster Assemblies .....	53
Adjusting Anti-Dive Springs .....	53
<b>SECTION 12—ELECTRONICS .....</b>	<b>54</b>
Removing/Installing the Joystick Assembly .....	54
Repositioning the Joystick.....	55
Disconnecting/Connecting the Joystick.....	56

---

# TABLE OF CONTENTS

**SECTION 13—BATTERIES ..... 58**

- Warnings For Handling and Replacing Batteries .....58
- Using the Proper Batteries.....58
- Removing/Installing the Batteries.....59
- Connecting/Disconnecting Battery Cables.....61
- Charging Batteries .....63
- Battery Charger Operation.....64

**SECTION 14—ACCESSORIES ..... 66**

- Installing/Removing the Crutch/Cane Holder.....66
- Installing/Removing the Oxygen Holder .....67
- Installing/Removing/Using the Walker Holder .....68

**NOTES ..... 70**

**GLOBAL LIMITED WARRANTY (EXCLUDING CANADA) ..... 71**

**CANADA LIMITED WARRANTY ..... 72**

## SPECIAL NOTES

Signal words are used in this manual and apply to hazards or unsafe practices which could result in personal injury or property damage. Refer to the table below for definitions of the signal words.

SIGNAL WORD	MEANING
DANGER	Danger indicates an imminently hazardous situation which, if not avoided, will result in death or serious injury.
WARNING	Warning indicates a potentially hazardous situation which, if not avoided, could result in death or serious injury.
CAUTION	Caution indicates a potentially hazardous situation which, if not avoided, may result in property damage, minor injury or both.

### NOTICE

**THE INFORMATION CONTAINED IN THIS DOCUMENT IS SUBJECT TO CHANGE WITHOUT NOTICE.**

#### WHEELCHAIR USER

As a manufacturer of wheelchairs, Invacare endeavors to supply a wide variety of wheelchairs to meet many needs of the end user. However, final selection of the type of wheelchair to be used by an individual rests solely with the user and his/her healthcare professional capable of making such a selection.

#### WHEELCHAIR TIE-DOWN RESTRAINTS AND SEAT RESTRAINTS

Wheelchair users should not be transported in vehicles of any kind while in wheelchairs. As of this date, the Department of Transportation has not approved any tie-down systems for transportation of a user while in a wheelchair, in a moving vehicle of any type.

It is Invacare's position that users of wheelchairs should be transferred into appropriate seating in vehicles for transportation and use be made of the restraints made available by the auto industry. Invacare cannot and does not recommend any wheelchair transportation systems.

### ⚠ WARNING

The seat positioning strap is a positioning belt only. It is not designed for use as a safety device withstanding high stress loads such as auto or aircraft safety belts. If signs of wear appear, the belt **MUST** be replaced immediately.

Invacare products are specifically designed and manufactured for use in conjunction with Invacare accessories. Accessories designed by other manufacturers have not been tested by Invacare and are not recommended for use with Invacare products.

The drive behavior initially experienced by the user may be different from other chairs previously used. This power wheelchair has Invacare's SureStep technology, a feature that provides the chair with optimum traction and stability when driving forward over transitions and thresholds of up to 1-inch.

**⚠ WARNING**

The following warnings apply specifically to the SureStep Feature.

- **DO NOT** use on inclines greater than 7°.
- **DO NOT** use on inclines with wet, slippery, icy or oily surfaces. This may include certain painted or otherwise treated wood surfaces.
- **DO NOT** traverse down ramps at high speed. Doing so will reduce traction and increase stopping distance.
- The end user's weight can substantially affect traction on sloped surfaces. Great care should be taken when traversing such slopes.

Wheelchairs should be examined during maintenance for signs of corrosion (water exposure, incontinence, etc.). Electrical components damaged by corrosion should be replaced **IMMEDIATELY**.

Wheelchairs that are used by incontinent users and/or are frequently exposed to water may require replacement of electrical components more frequently.

To determine and establish your particular safety limits, practice use of this product on various sloping surfaces in the presence of a qualified healthcare provider before attempting active use of this wheelchair. Other general warnings listed within this document also apply.

---

# LABEL LOCATION

The POSITIVE (+) RED Battery Cable MUST connect to the POSITIVE (+) Battery Terminal(s)/ Post(s). The NEGATIVE (-) BLACK Battery Cable MUST connect to the NEGATIVE (-) Battery Terminal(s)/Post(s). DO NOT allow Battery Cable(s) to contact the opposite Battery Terminal(s)/Post(s). Install protective caps on POSITIVE (+) and NEGATIVE (-) battery terminals. Replace cable(s) immediately if cable(s) insulation becomes damaged. Failure to observe these warnings may result in an electrical short with serious personal injury and/or damage to the electrical system. See Owner's Manual. DO NOT remove fuse or mounting hardware from POSITIVE (+) RED battery cable mounting screw. DO NOT REMOVE THIS LABEL.

1143237 located on underside of shroud

**⚠ WARNING**  
Only qualified technicians should replace or adjust the anti-dive springs.  
1141481 Rev B

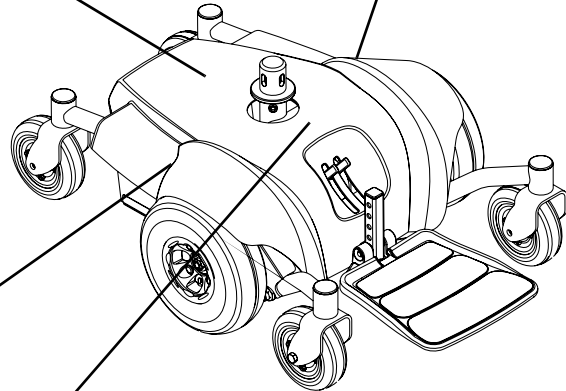

**⚠ WARNING**  
Only qualified technicians should replace or adjust the anti-dive springs.  
1141481 Rev B

NO WHEELCHAIR HAS BEEN APPROVED FOR USE AS A SEATING SURFACE WITHIN A MOTOR VEHICLE. THIS LABEL IS FOR INFORMATIONAL PURPOSES ONLY. LIABILITY ISSUES WERE NOT CONSIDERED IN THE ATTACHMENT OF THIS LABEL.

AUCUN FAUTEUIL ROULANT N'A ÉTÉ APPROUVÉ POUR ÊTRE UTILISÉ COMME SIÈGE À L'INTÉRIEUR D'UN VÉHICULE MOTORISÉ. CETTE ÉTIQUETTE NE PEUT ÊTRE UTILISÉE QU'A TITRE D'INFORMATION ET N'A PAS ÉTÉ AFFICHÉE ICI POUR DES RAISONS DE RESPONSABILITÉ LÉGALE



Weight Capacity Label located here

Serial number label is located here

# TYPICAL PRODUCT PARAMETERS

	FOLD-DOWN SEAT	OFFICE STYLE SEMI-RECLINE SEAT	SEMI-RECLINE SEAT W/ SOLID SEAT PAN
<b>SEAT WIDTH:</b>	18 inches	16 - 20 inches	
<b>SEAT DEPTH:</b>	17 inches	16 - 18 inches	16 - 20 inches
<b>BACK HEIGHT:</b>	16 inches	23½ inches (w/ headrest) 18¾ inches (w/o headrest)	
<b>BACK ANGLE RANGE:</b>	95° Fixed	92 - 115°	90 - 114°
<b>UPHOLSTERY:</b>	Black Vinyl	Dark Grey Vinyl	Light Grey Vinyl
<b>SEAT-TO-FLOOR (WITH FOOTBOARD)</b>	19 to 23 inches		18 to 22 inches (w/o Seat Cushion)
<b>OVERALL WIDTH (WITHOUT JOYSTICK):</b>	24 inches		
<b>OVERALL HEIGHT:</b>	33 - 38 inches	41½ inches	35 - 43¾
<b>OVERALL LENGTH WITH FOOTBOARD UP:</b>	34 inches	34 inches	
<b>WITH FOOTBOARD DOWN:</b>	38 inches	39½ inches	
<b>DRIVE WHEELS/TIRES:</b>	10 x 3-inch (Flat Free inserts)		
<b>CASTER:</b>	6 x 2-inch		
<b>FOOTRESTS/LEGRESTS:</b>	Flip Up, Depth and Height Adjustable, Footboard.	Flip Up, Depth and Height Adjustable, Footboard, Swingaway Front Rigging, Elevating Legrest	

## TYPICAL PRODUCT PARAMETERS

	FOLD-DOWN SEAT	OFFICE STYLE SEMI-RECLINE SEAT	SEMI-RECLINE SEAT W/ SOLID SEAT PAN
<b>*WEIGHT</b>			
W/O BATTERIES AND FOOTPLATE:	110 lbs	124 lbs	129 lbs
W/BATTERIES (U1) AND FOOTPLATE:	161 lbs	175 lbs	180 lbs
<b>SHIPPING</b>			
BASE W/O BATTERIES:	80 lbs	80 lbs	80 lbs
BASE W/ BATTERIES	130 lbs	130 lbs	130 lbs
SEAT:	30 lbs	44 lbs	49 lbs
<b>ARMRESTS:</b>	Adjustable Width, Angle, and Depth	Adjustable Width, Angle, and Height	
<b>BATTERIES:</b>	U1 - Quantity 2		
<b>WEIGHT LIMITATION:</b>	300 lbs		
<b>PERFORMANCE</b>			
SPEED:	0 to 5 m.p.h.		
TURNING RADIUS:	Front: 18 inches/Rear: 19 inches		
**RANGE (VARIABLE):	up to 12 miles		

\*NOTE: Includes accessories.

\*\*NOTE: Values for range are calculated for maximum chair weight rating using largest batteries applicable (U1), per test procedures described in ANSI/RESNA WC/VOL2-1998 Section 4 and meet federal reimbursement requirements for this product. While considered typical, they are derived based on certain ideal conditions. Variances in battery condition, user weight, usage pattern or overall terrain conditions will result in actual values for range that differ from these stated values. Users should become accustomed to how their unique conditions impact their individual results. Users should become familiar with the battery discharge indicator on the joystick to determine the range of their wheelchair. Refer to [Battery Charger Operation](#) on page 64 for more information about the battery discharge indicator.

---

# SECTION I—GENERAL GUIDELINES

---

## **⚠ WARNING**

**SECTION I - GENERAL GUIDELINES** contains important information for the safe operation and use of this product.

---

## **Controller Settings/Repair or Service**

Set-up of the Electronics Control Unit is to be performed only by a qualified technician. The final adjustments of the controller may affect other activities of the wheelchair. Damage to the equipment could occur if improperly set-up or adjusted.

Wheelchairs should be examined during maintenance for signs of corrosion (water exposure, incontinence, etc.). Electrical components damaged by corrosion should be replaced IMMEDIATELY.

Wheelchairs that are used by incontinent users and/or are frequently exposed to water may require replacement of electrical components more frequently.

## **Accessories Information**

Extreme care should be exercised when using oxygen in close proximity to electric circuits and other combustible materials. Contact your oxygen supplier for instruction in the use of oxygen.

Invacare products are specifically designed and manufactured for use in conjunction with Invacare accessories. Accessories designed by other manufacturers have not been tested by Invacare and are not recommended for use with Invacare products.

## **Operation Information**

Performance adjustments should only be made by professionals of the healthcare field or persons fully conversant with this process and the driver's capabilities. Incorrect settings could cause injury to the driver, bystanders, damage to the chair and to surrounding property.

After the wheelchair has been set-up, check to make sure that the wheelchair performs to the specifications entered during the set-up procedure. If the wheelchair does not perform to specifications, turn the wheelchair Off immediately and re-enter set-up specifications. Repeat this procedure until the wheelchair performs to specifications.

ALWAYS shift your weight in the direction you are turning. DO NOT shift your weight in the opposite direction of the turn. Shifting your weight in the opposite direction of the turn may cause the inside drive wheel to lose traction and the wheelchair to tip over.

DO NOT shift your weight or sitting position toward the direction you are reaching as the wheelchair may tip over.

## SECTION I—GENERAL GUIDELINES

---

DO NOT engage or disengage the motor release levers until the power is in the Off position.

DO NOT operate on roads, streets or highways.

DO NOT climb, go up or down ramps or traverse slopes greater than 7°.

DO NOT attempt to move up or down an incline with a water, ice or oil film.

DO NOT attempt to drive over curbs or obstacles. Doing so may cause your wheelchair to turn over and cause bodily harm or damage to the chair.

DO NOT leave the power button in the On position when entering or exiting your wheelchair.

DO NOT stand on the frame of the wheelchair.

Limited Clearance Between Footboard and Caster - The user's feet MUST remain centered on the footboard, away from the footboard sides, while operating the wheelchair. If the user's feet are allowed to rest off the side of the footboard they may come in contact with the caster possibly resulting in injury.

DO NOT stand on the flip-up footboard, otherwise damage may occur. When getting in or out of the wheelchair, make sure that the flip-up footboard is in the upward position.

DO NOT stand on the front riggings, otherwise damage may occur. When getting in or out of the wheelchair, make sure that the footplates on the front riggings are in the upward position or moved out of the way.

ALWAYS wear your seat positioning strap. The seat positioning strap is a positioning belt only. It is not designed for use as a safety device withstanding high stress loads such as auto or aircraft safety belts. If signs of wear appear, belt MUST be replaced immediately.

Make sure the detent balls of the quick-release pin are fully released beyond the outer edge of the tube before operating the wheelchair. Otherwise, injury and/or damage may result.

Keep detent balls clean.

Before performing any maintenance, adjustment or service verify that On/Off switch on the joystick is in the Off position.

Avoid storing or using the wheelchair near open flame or combustible products. Serious injury or damage to property may result.

## Batteries

The warranty and performance specifications contained in this manual are based on the use of deep cycle gel cell batteries. Invacare strongly recommends their use as the power source for this unit.

Carefully read battery/battery charger information prior to installing, servicing or operating your wheelchair.

The use of rubber gloves is recommended when working with batteries.

Some battery manufacturers mold a carrying strap and/or hold down flanges directly into the battery case. Batteries that interfere with the battery box cannot be used for these applications. Attempting to “wedge” a battery into a battery box may damage the box, the battery and/or be a fire hazard, resulting in serious injury or further damage to property.

## Charging Batteries

---

### **⚠ DANGER**

**When using an extension cord, use only a three wire extension cord having at least 16 AWG (American Wire Gauge) wire and the same or higher electrical rating as the device being connected. Use of improper extension cord could result in a risk of fire and electric shock. Three prong to two prong adapters should not be used. Use of three prong adapters can result in improper grounding and present a shock hazard to the user.**

---

NEVER attempt to recharge the batteries by attaching cables directly to the battery terminals.

DO NOT attempt to recharge the batteries and operate the wheelchair at the same time.

DO NOT operate wheelchair with extension cord attached to the AC cable.

DO NOT attempt to recharge the batteries when the wheelchair has been exposed to any type of moisture.

DO NOT attempt to recharge the batteries when the wheelchair is outside.

DO NOT sit in the wheelchair while charging the batteries.

Read and carefully follow the manufacturer’s instructions for each charger (supplied or purchased). If charging instructions are not supplied, consult a qualified technician for proper procedures.

Ensure the pins of the extension cord plug are the same number, size, and shape as those on the charger.

DO NOT under any circumstances cut or remove the round grounding plug from the charger AC cable plug or the extension cord plug.

## Grounding Instructions

DO NOT, under any circumstances, cut or remove the round grounding prong from any plug used with or for Invacare products. Some devices are equipped with three-prong (grounding) plugs for protection against possible shock hazards and fire. Where a two-prong wall receptacle is encountered, it is the personal responsibility and obligation of the customer to contact a qualified electrician and have the two-prong receptacle replaced with a properly grounded three-prong wall receptacle in accordance with the National Electrical Code. If you must use an extension cord, use only a three-wire extension cord having the same or higher electrical rating as the device being connected. In addition, Invacare has placed RED/ORANGE warning tags on some equipment. DO NOT remove these tags.

## Rain Test

Invacare has tested its power wheelchairs in accordance with ISO 7176 “Rain Test.” This provides the end user or his/her assistant sufficient time to remove his/her power wheelchair from a rain storm and retain wheelchair operation.

DO NOT leave power wheelchair in a rain storm of any kind.

DO NOT use power wheelchair in a shower.

DO NOT store power wheelchair in a damp area for an extended period of time.

Direct exposure to excessive rain or dampness may cause the chair to malfunction electrically and mechanically, may cause the chair to prematurely rust or may damage the upholstery.

Check to ensure that the RED and BLACK battery terminal caps are secured in place, joystick boot is not torn or cracked where water can enter and that all electrical connections are secure at all times.

DO NOT use the wheelchair if the joystick boot is torn or cracked. If the joystick boot becomes torn or cracked, replace immediately.

## Weight Training

Invacare does not recommend the use of its wheelchairs as a weight training apparatus. Invacare wheelchairs have not been designed or tested as a seat for any kind of weight training. If occupant uses said wheelchair as a weight training apparatus, Invacare shall not be liable for bodily injury and the warranty is void.

## Weight Limitation

The M41 wheelchair with SureStep has a weight limitation of 300 lbs.

---

## SECTION 2—EMI INFORMATION

---

### **⚠ WARNING**

**CAUTION: IT IS VERY IMPORTANT THAT YOU READ THIS INFORMATION REGARDING THE POSSIBLE EFFECTS OF ELECTROMAGNETIC INTERFERENCE ON YOUR POWERED WHEELCHAIR.**

#### **Electromagnetic Interference (EMI) From Radio Wave Sources**

Powered wheelchairs and motorized scooters (in this text, both will be referred to as powered wheelchairs) may be susceptible to electromagnetic interference (EMI), which is interfering electromagnetic energy (EM) emitted from sources such as radio stations, TV stations, amateur radio (HAM) transmitters, two way radios, and cellular phones. The interference (from radio wave sources) can cause the powered wheelchair to release its brakes, move by itself, or move in unintended directions. It can also permanently damage the powered wheelchair's control system. The intensity of the interfering EM energy can be measured in volts per meter (V/m). Each powered wheelchair can resist EMI up to a certain intensity. This is called its "immunity level." The higher the immunity level, the greater the protection. At this time, current technology is capable of achieving at least a 20 V/m immunity level, which would provide useful protection from the more common sources of radiated EMI.

There are a number of sources of relatively intense electromagnetic fields in the everyday environment. Some of these sources are obvious and easy to avoid. Others are not apparent and exposure is unavoidable. However, we believe that by following the warnings listed below, your risk to EMI will be minimized.

The sources of radiated EMI can be broadly classified into three types:

- 1) Hand-held Portable transceivers (transmitters-receivers with the antenna mounted directly on the transmitting unit. Examples include: citizens band (CB) radios, "walkie talkie", security, fire and police transceivers, cellular telephones, and other personal communication devices).

**NOTE:** *Some cellular telephones and similar devices transmit signals while they are ON, even when not being used.*

- 2) Medium-range mobile transceivers, such as those used in police cars, fire trucks, ambulances and taxis. These usually have the antenna mounted on the outside of the vehicle; and
- 3) Long-range transmitters and transceivers, such as commercial broadcast transmitters (radio and TV broadcast antenna towers) and amateur (HAM) radios.

**NOTE:** *Other types of hand-held devices, such as cordless phones, laptop computers, AM/FM radios, TV sets, CD players, cassette players, and small appliances, such as electric shavers and hair dryers, so far as we know, are not likely to cause EMI problems to your powered wheelchair.*

---

**⚠ WARNING**

**Powered Wheelchair Electromagnetic Interference (EMI)**

Because **EM** energy rapidly becomes more intense as one moves closer to the transmitting antenna (source), the **EM** fields from hand-held radio wave sources (transceivers) are of special concern. It is possible to unintentionally bring high levels of **EM** energy very close to the powered wheelchair's control system while using these devices. This can affect powered wheelchair movement and braking. Therefore, the warnings listed below are recommended to prevent possible interference with the control system of the powered wheelchair.

Electromagnetic interference (**EMI**) from sources such as radio and TV stations, amateur radio (**HAM**) transmitters, two-way radios, and cellular phones can affect powered wheelchairs and motorized scooters.

**FOLLOWING THE WARNINGS LISTED BELOW SHOULD REDUCE THE CHANCE OF UNINTENDED BRAKE RELEASE OR POWERED WHEELCHAIR MOVEMENT WHICH COULD RESULT IN SERIOUS INJURY.**

- 1) Do not operate hand-held transceivers (transmitters receivers), such as citizens band (**CB**) radios, or turn **ON** personal communication devices, such as cellular phones, while the powered wheelchair is turned **ON**;
- 2) Be aware of nearby transmitters, such as radio or TV stations, and try to avoid coming close to them;
- 3) If unintended movement or brake release occurs, turn the powered wheelchair **OFF** as soon as it is safe;
- 4) Be aware that adding accessories or components, or modifying the powered wheelchair, may make it more susceptible to **EMI** (**NOTE: There is no easy way to evaluate their effect on the overall immunity of the powered wheelchair**); and
- 5) Report all incidents of unintended movement or brake release to the powered wheelchair manufacturer, and note whether there is a source of **EMI** nearby.

**Important Information**

- 1) 20 volts per meter (**V/m**) is a generally achievable and useful immunity level against **EMI** (as of May 1994) (the higher the level, the greater the protection);
- 2) This device has been tested to a radiated immunity level of 20 volts per meter;
- 3) The immunity level of the product is unknown.

Modification of any kind to the electronics of this wheelchair as manufactured by Invacare may adversely affect the **EMI** immunity levels.

---

## SECTION 3—INITIAL SETUP

### ⚠ WARNING

After any adjustments, repair or service and before use, make sure that all attaching hardware is tightened securely - otherwise injury or damage may result.

Before performing any maintenance, adjustment or service verify that On/Off switch on the joystick is in the Off position.

### Setup Checklist

NOTE: For this procedure, refer to FIGURE 3.1.

Follow the checklist below to ensure the wheelchair is properly setup before initial use.

- ❑ Place the wheelchair in a well ventilated area where work can be performed without risking damage to carpeting or floor covering.
- ❑ Ensure the battery wiring harnesses are properly connected to the right and left batteries. Refer to [Connecting/Disconnecting Battery Wiring Harness](#) on page 63.
- ❑ Install the batteries into the wheelchair base. Refer to [Removing/Installing the Batteries](#) on page 61.

NOTE: *Removing/Installing the Batteries* includes the following procedures:

- Disconnecting/Connecting the Joystick
- Removing/Installing the Top Shroud
- Removing/Installing the Seat Assembly
- Removing/Installing the Joystick Assembly

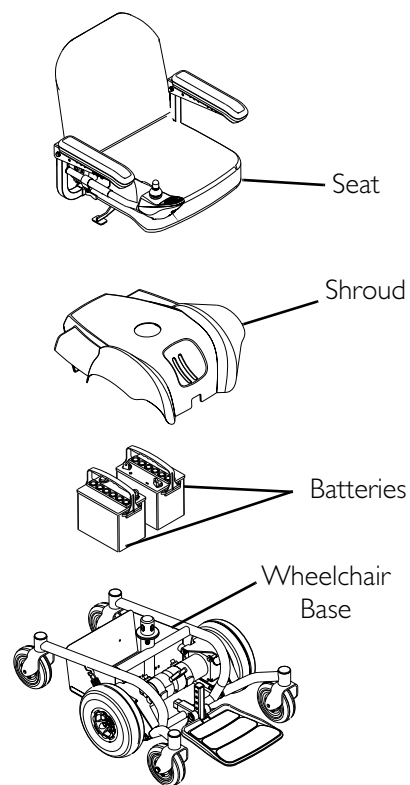

**FIGURE 3.1** Setup Checklist

## SECTION 4—SAFETY/HANDLING OF WHEELCHAIRS

“Safety and Handling” of the wheelchair requires the close attention of the wheelchair user as well as the assistant. This manual points out the most common procedures and techniques involved in the safe operation and maintenance of the wheelchair. It is important to practice and master these safe techniques until you are comfortable in maneuvering around the frequently encountered architectural barriers.

Use this information only as a “basic” guide. The techniques that are discussed on the following pages have been used successfully by many.

Individual wheelchair users often develop skills to deal with daily living activities that may differ from those described in this manual. Invacare recognizes and encourages each individual to try what works best for him/her in overcoming architectural obstacles that they may encounter, however all warnings and cautions given in this manual **MUST** be followed. Techniques in this manual are a starting point for the new wheelchair user and assistant with “safety” as the most important consideration for all.

### Stability and Balance

---

#### **WARNING**

**ALWAYS** wear your seat positioning strap. The seat positioning strap is a positioning belt only. It is not designed for use as a safety device withstanding high stress loads such as auto or aircraft safety belts. If signs of wear appear, belt **MUST** be replaced immediately.

**DO NOT** attempt to reach objects if you have to move forward in the seat or pick them up from the floor by reaching down between your knees.

Proper positioning is essential for your safety. When reaching, leaning, bending or bending forward, it is important to use the casters as a tool to maintain stability and balance.

Many activities require the wheelchair user to reach, bend and transfer in and out of the wheelchair. These movements will cause a change to the normal balance, center of gravity, and weight distribution of the wheelchair. To determine and establish your particular safety limits, practice bending, reaching and transferring activities in several combinations in the presence of a qualified healthcare professional before attempting active use of the wheelchair.

Be aware that carrying heavy objects on your lap while occupying the wheelchair may adversely affect the stability of the wheelchair, resulting in serious bodily injury to the user, damage to the wheelchair and surrounding property.

This wheelchair has been designed to accommodate one individual. If more than one individual occupies the wheelchair this may adversely affect the stability of the wheelchair, resulting in serious bodily injury to the user and passenger and damage to the wheelchair and surrounding property.

To assure stability and proper operation of your wheelchair, you must at all times maintain proper balance. Your wheelchair has been designed to remain upright and stable during normal daily activities as long as you do not move beyond the center of gravity. DO NOT lean forward out of the wheelchair any further than the length of the armrests.

## Coping With Everyday Obstacles

*NOTE: For this information, refer to FIGURE 4.1.*

Coping with the irritation of everyday obstacles can be alleviated somewhat by learning how to manage your wheelchair. Keep in mind your center of gravity to maintain stability and balance.

While the walking beam allows you to traverse up to a 1-inch bump or threshold, stopping after the wheels cross the bump poses a problem. The chair cannot reverse over the bump at this point. Continue forward and then turn around.

While the wheelchair is designed for use primarily in and around the home, the provider should determine whether this chair is suitable for the actual environment the chair will be used in.

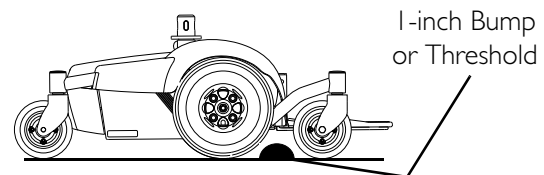

**FIGURE 4.1** Coping With Everyday Obstacles

DO NOT go down ramp at full speed. Some seat/back positions will cause wheelchair to feel unstable.

---

### CAUTION

**Be aware of condition of ramp. Traction will be diminished/nonexistent on a slippery surface. Proceed with caution.**

---

## A Note to Wheelchair Assistants

When assistance to the wheelchair user is required, remember to use good body mechanics. Keep your back straight and bend your knees whenever tilting wheelchair or traversing curbs or other impediments.

Also, be aware of detachable parts such as arms or legrests. These must NEVER be used to move the wheelchair or as lifting supports, as they may be inadvertently released, resulting in possible injury to the user and/or assistant(s).

When learning a new assistance technique, have an experienced assistant help you before attempting it alone.

## Pinch Points

---

### **⚠ WARNING**

Pinch point may occur when adjusting the arm angle position (Detail “A”).

Pinch point may occur when rotating the footboard assembly (Detail “B”).

---

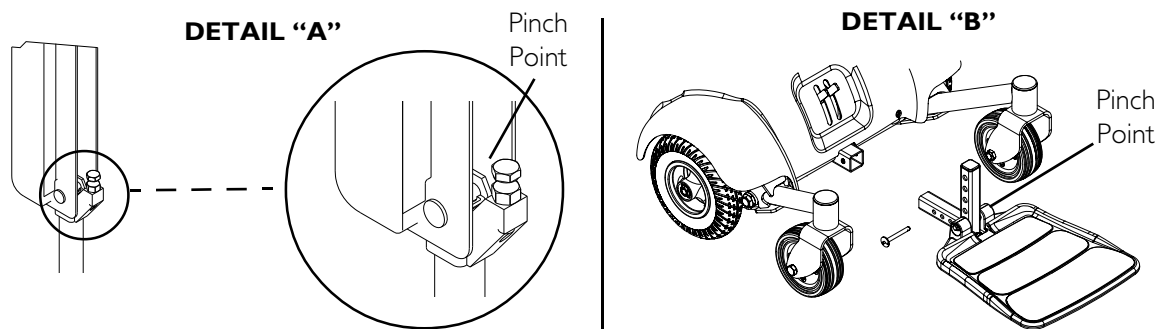

**FIGURE 4.2** Pinch Points

## Lifting/Stairways

---

### **⚠ WARNING**

**DO NOT** attempt to move an occupied power wheelchair between floors using a stairway. Use an elevator to move an occupied power wheelchair between floors. If moving a power wheelchair between floors by means of a stairway, the occupant **MUST** be removed and transported independently of the power wheelchair.

Extreme caution is advised when it is necessary to move an unoccupied power wheelchair up or down the stairs. Invacare recommends using two assistants and making thorough preparations.

Use only secure, nondetachable parts for hand-hold supports.

It is strongly recommended to lift the wheelchair only by the rear frame and the front forks - otherwise injury or damage may occur.

**DO NOT** attempt to lift the wheelchair by any removable (detachable) parts. Lifting by means of any removable (detachable) parts of a wheelchair may result in injury to the user or damage to the wheelchair.

The weight of the wheelchair with batteries and without the user is approximately 125 lbs. Use proper lifting techniques (lift with your legs) to avoid injury.

---

*NOTE: For this procedure, refer to FIGURE 4.3 on page 21.*

Follow this procedure for moving the wheelchair between floors when an elevator is not available or lifting the wheelchair is necessary:

*NOTE: When using a stairway to move the wheelchair, seat and any accessories, move all wheelchair components away from the stairway prior to reassembly.*

*NOTE: This procedure needs two assistants to lift the wheelchair to transport it.*

1. Remove the occupant from the wheelchair.
2. Remove the seat. Refer to Removing/Installing the Seat Assembly on page 37.
3. Remove any accessories on the wheelchair.
4. Bend your knees and keep your back straight.
5. Ensure that the casters are oriented as shown in FIGURE 4.3.
6. Using the rear and front forks as hand hold supports, transfer the wheelchair base to desired location.
7. Using non-removable (nondetachable) parts, transfer the seat and any accessories to desired location.
8. Reinstall any accessories that were removed in STEP 3.
9. Reinstall the seat. Refer to Removing/Installing the Seat Assembly on page 37.

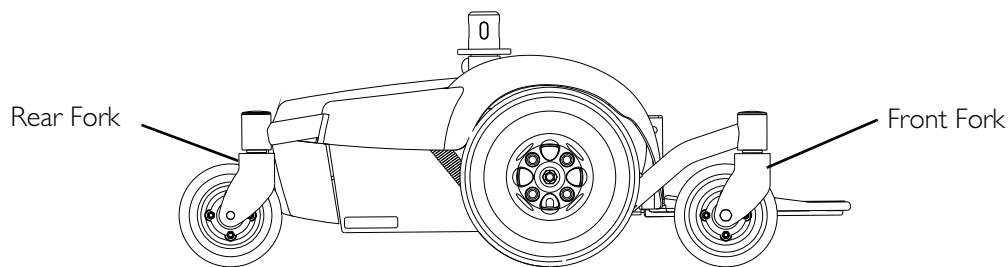

**FIGURE 4.3** Lifting/Stairways

---

**⚠ WARNING - ESCALATORS**

**DO NOT** use an escalator to move a wheelchair between floors. Serious bodily injury may occur.

---

## Transferring To and From Other Seats

---

### ⚠ WARNING

**ALWAYS** turn the wheelchair power **Off** and engage the **Motor Release Levers** to prevent the wheels from moving before attempting to transfer in or out of the wheelchair. Also, make sure every precaution is taken to reduce the gap distance by aligning both the front and rear casters parallel with the object you are transferring onto.

---

### CAUTION

**When transferring, position yourself as far back as possible in the seat. This will prevent broken screws, damaged upholstery and the possibility of the wheelchair tipping forward.**

---

*NOTE: For this procedure, refer to FIGURE 4.4 on page 22.*

*NOTE: This activity may be performed independently provided you have adequate mobility and upper body strength.*

1. Position the wheelchair as close as possible along side the seat to which you are transferring, with the rear casters pointing away from it.
2. After the wheelchair is positioned properly for transfer, verify that the motor release levers are engaged. Refer to [Engaging/Disengaging Motor Release Lever](#) on page 51.
3. Flip back or remove arm on side of wheelchair you are transferring from.
4. Shift body weight into seat with transfer.

During independent transfer, little or no seat platform will be beneath you. Use a transfer board if at all possible.

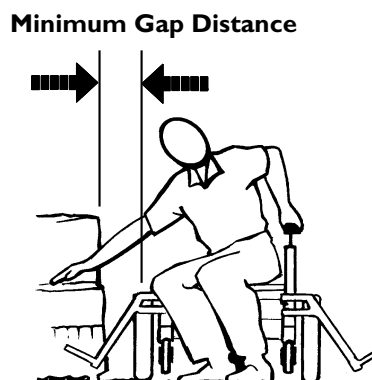

**FIGURE 4.4** Transferring To and From Other Seats

## Reaching, Leaning and Bending - Forward

*NOTE: For this procedure, refer to FIGURE 4.5.*

Position the front and rear casters so that they are extended as far forward as possible and engage motor release levers.

---

### **⚠ WARNING**

**DO NOT attempt to reach objects if you have to move forward in the seat or pick them up from the floor by reaching down between your knees.**

---

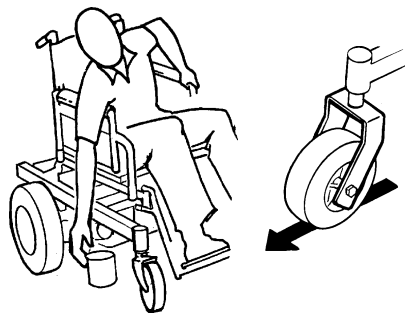

**FIGURE 4.5** Reaching, Leaning and Bending - Forward

## Reaching and Bending - Backward

### **⚠ WARNING**

**DO NOT lean over the top of the back upholstery. This will change your center of gravity and may cause you to tip over.**

---

*NOTE: For this procedure, refer to FIGURE 4.6.*

Position wheelchair as close as possible to the desired object. Point the front AND rear casters rearward to create the longest possible wheelbase. Reach back only as far as your arm will extend without changing your sitting position.



**FIGURE 4.6** Reaching and Bending - Backward

## SECTION 5—SAFETY INSPECTION

### Safety Inspection Checklists

---

#### **CAUTION**

**As with any vehicle, wheels and tires should be checked periodically for cracks and wear and should be replaced as necessary.**

---

Initial adjustments should be made to suit your personal body structure needs and preference. Thereafter follow these maintenance procedures:

#### **Inspect/Adjust Initially**

- Ensure that the wheelchair rolls straight (no excessive drag or pull to one side).
- Ensure that the arms are secure but easy to release and adjustment levers engage properly.
- Ensure that adjustable height arms operate and lock securely.
- Ensure armrest pads sit flush against arm.
- Ensure seat is secured to wheelchair frame.
- Ensure seat release latch is functional. Replace if necessary.
- Clean seat upholstery and armrests.
- Ensure wheel mounting nuts are secure on drive wheels.
- Ensure no excessive side movement or binding occurs when drive wheels are lifted and spun when disengaged (freewheeling).
- Inspect caster assembly has proper tension when caster is spun. Caster should come to a gradual stop.
- Loosen/tighten caster locknut if wheel wobbles noticeably or binds to a stop.
- Ensure all caster/wheel/fork/headtube fasteners are secure.
- Ensure casters are free of debris.
- Inspect tires for flat spots and wear.
- Inspect electrical components for signs of corrosion. Replace if corroded or damaged.
- Check that all labels are present and legible. Replace if necessary.

**Inspect/Adjust Weekly**

- Seat is secured to wheelchair frame.
- Seat and/or back upholstery have no rips and DO NOT sag. Replace if necessary.
- Seat release latch is not worn and is functional. Replace if necessary.
- Inspect tires for flat spots and wear.
- Ensure that casters are free of debris.
- Ensure arm pivot points are not worn and/or loose. Replace if necessary.
- Check that cables are routed and secured properly to ensure that cables DO NOT become entangled and damaged during normal operation of seating system.

**Inspect/Adjust Monthly**

- Ensure wheel mounting nuts are secure on drive wheels.
- Ensure no excessive side movement or binding occurs when drive wheels are lifted and spun when disengaged (freewheeling).
- Inspect caster assembly has proper tension when caster is spun. Caster should come to a gradual stop.
- Ensure that casters are free of debris.
- Loosen/tighten caster locknut if wheel wobbles noticeably or binds to a stop.
- Ensure all caster/wheel/fork/headtube fasteners are secure.
- Inspect for any loose hardware on the wheelchair.
- Inspect the seat positioning strap for signs of wear. Replace if worn or damaged.
- Ensure that the buckle on the seat positioning strap latches. Replace if necessary.
- Verify that the hardware that attaches the seat positioning strap to the seat frame is secure and undamaged. Replace if necessary.
- Inspect electrical components for signs of corrosion. Replace if corroded or damaged.
- Check that all labels are present and legible. Replace if necessary.

## Inspect/Adjust Periodically

- Ensure wheelchair rolls straight (no excessive drag or pull to one side).
- Ensure that casters are free of debris.
- Ensure arms are secure but easy to release and adjustment levers engage properly.
- Ensure adjustable height arms operate and lock securely.
- Ensure arm pivot points are not worn and/or loose. Replace if necessary.
- Ensure armrest pads sit flush against arm.
- Ensure seat and/or back upholstery have no rips and DO NOT sag. Replace if necessary.
- Ensure seat release latch is not worn. Replace if necessary.
- Clean upholstery and armrests.
- Inspect electrical components for signs of corrosion. Replace if corroded or damaged.
- Check that all labels are present and legible. Replace if necessary.

## Troubleshooting Guide

*NOTE: For additional troubleshooting information and explanation of error codes, refer to the Electronics Manual supplied with each wheelchair.*

### All Wheelchairs

SYMPTOM	PROBABLE CAUSE	SOLUTIONS
Limited driving distance.	Batteries not charged long enough.  Batteries weak; wont hold charge.	Charge batteries overnight or ensure 8 hours of charge time between use. Ensure correct setting on charger. Replace Batteries.
Batteries not charging.	Charger not working. Battery connections loose. No current at wall outlet. Bad connection on charger, charger cable, plug or internal wiring problem.	Have charger replaced. Contact Dealer/Invacare. Check all connections. Secure connections. Switch to another wall outlet. Replace charger or internal repairs may be required. Contact Dealer/Invacare.
Batteries draw excessive current when charging.	Battery failure.	Have batteries checked for shorted cell. Replace if necessary.
Charger indicator shows low charge level immediately after charging.	Batteries weak, wont hold charge. Electrical malfunction. Charger malfunction.	Replace Batteries.  Contact Dealer/Invacare. Replace charger. Contact Dealer/Invacare.
Battery indicator flashes the charge level is low immediately after recharging.	Weak Batteries. Charger malfunction. Electrical malfunction	Replace batteries. Replace charger. Contact Dealer/Invacare. Contact Dealer/Invacare.

SYMPTOM	PROBABLE CAUSE	SOLUTIONS
Wheelchair will not drive.	Motor release levers are disengaged. Batteries require charging.  Charger plugged in.  Circuit breaker tripped.	Engage motor release levers.  Charge batteries. Make sure the setting on the charger is correct. Unplug charger from wall outlet before operating the wheelchair. Reset circuit breaker. If breaker trips again, it may indicate need for internal repair. Contact Dealer/Invacare.
Motor “chatters” or runs irregularly.	Electrical malfunction.	Contact Dealer/Invacare.
Only one drive wheel turns.	Electrical malfunction. One motor lock is disengaged.	Contact Dealer/Invacare for service. Engage motor lock.
Joystick erratic or does not respond as desired.	Electrical malfunction. Controller programmed improperly.	Contact Dealer/Invacare for service. Reprogram controller (Refer to electronics manual supplied with wheelchair).
Wheelchair does not respond to commands.	Poor battery terminal connection.	Have terminals cleaned.
Power indicator off - even after recharging.	Electrical malfunction.	Contact Dealer/Invacare for service.

## Troubleshooting - Electrical





*NOTE: For additional troubleshooting information and explanation of error codes, refer to the individual Electronics Manual supplied with each wheelchair.*

### SPJ+ Joysticks

The joystick information gauge and the service indicator give indications of the type of fault or error detected by the control module. When a fault is detected, the wheelchair may stop and not drive. The LEDs on the information gauge may flash in a particular pattern or the service indicator light will flash. The number or type of flashes indicates the nature of the error. If multiple errors are found, only the first error encountered by the control module will be displayed.

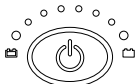
## SECTION 5—SAFETY INSPECTION

### Information Gauge Display Diagnostics

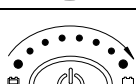
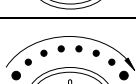
DISPLAY	DESCRIPTION	DEFINITION	COMMENTS
 <p>Information Gauge Display</p>			
	All LEDs are off.	Power is off.	
	All LEDs are on.	Power is on.	Fewer than three LEDs on implies reduced battery charge.
	Left RED LED is flashing.	Battery charge is low.	The batteries should be charged as soon as possible.
	Right to Left slow "Chase"	Joystick is in lock mode.	Press the horn button twice within 10 seconds to unlock joystick.
	Left to Right "chase" alternating with steady display.	Joystick is in programming, inhibit and/or charging mode.	The steady LEDs indicate the current state of the battery charge.
	Left to Right rapid chase.	Joystick is in charge inhibit.	No battery charge indication.

### Service Indicator Light Diagnostics

NUMBER OF FLASHES	ERROR CODE DESCRIPTION	POSSIBLE SOLUTION
1	User Fault	Release joystick to neutral and try again.
2	Battery Fault	Charge the batteries. Refer to <a href="#">Charging Batteries</a> on page 65. Check that battery cables are connected properly. Refer to <a href="#">Connecting/Disconnecting Battery Wiring Harness</a> on page 63. If necessary, replace batteries. Refer to <a href="#">Removing/Installing the Batteries</a> on page 61.
3	Left Motor Fault	Check the left motor, connections and cabling. If necessary, contact Invacare/Dealer for service.
4	Right Motor Fault	Check the right motor, connections and cabling. If necessary, contact Invacare/Dealer for service.
5	Left Park Brake Fault	Check the left park brake, connections and cabling. If necessary, contact Invacare/Dealer for service.
6	Right Park Brake Fault	Check the right park brake, connections and cabling. If necessary, contact Invacare/Dealer for service.
7	User Interface Fault	Display PCB fault. Contact Invacare/Dealer for service.
8	Controller Fault	Contact Invacare/Dealer for service.
9	SPJ-INT Bus Communications Fault	Contact Invacare/Dealer for service.

# SECTION 6—WHEELCHAIR OPERATION

## ⚠ WARNING

After any adjustments, repair or service and before use, make sure that all attaching hardware is tightened securely - otherwise injury or damage may result.

Set-up of the Electronics Control Unit is to be performed only by a qualified technician. The final adjustments of the controller may affect other activities of the wheelchair. Damage to the equipment could occur if improperly set-up or adjusted.

## Turning the Power On/Off

NOTE: For this procedure, refer to FIGURE 6.1.

1. To turn the power On by pressing the On/Off button.

NOTE: After turning power on, the battery gauge indicators will light briefly. One of the following will occur after that:

- The current battery charge will be indicated on the information gauge display.
  - Lock Mode will be indicated by all LEDs flashing briefly and the information gauge LEDs chasing slowly from right to left. If this occurs, press the horn button two times within ten seconds to unlock the joystick.
2. Turning the power Off can be achieved by pressing the On/Off button.

NOTE: If the joystick has been programmed for lock mode, holding the On/Off button down for four seconds will lock the joystick. The LEDs will flash briefly and the horn will sound a short beep.

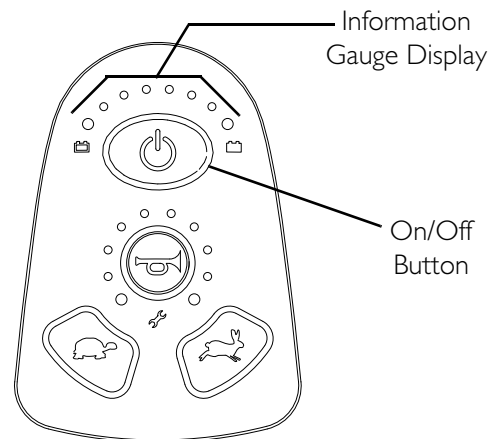

FIGURE 6.1 Turning the Power On/Off

## Using the Joystick to Drive the Wheelchair

*NOTE: For this procedure, refer to FIGURE 6.2.*

The joystick is located at the front of the joystick housing and provides smooth control of speed and direction. It is equipped with 360 degrees of mobility for ease of operation. The joystick is spring-loaded, and automatically returns to the upright (neutral) position when released. Pushing the joystick in a given direction causes the wheelchair to move in that direction.

The joystick has proportional drive control, meaning that the further it is pushed from the upright (neutral) position, the faster the wheelchair moves. The maximum speed, however, is limited by the speed control setting.

To slow the wheelchair to a stop, simply release the joystick. The wheelchair has automatic speed and direction compensation to minimize corrections.

When first learning to drive, select a slow speed and try to drive the wheelchair as slowly as possible by pushing the joystick slightly forward. This exercise will help you learn to utilize the full potential of the proportional control and allow you to start and stop smoothly.

To drive the wheelchair, perform the following:

1. Adjust the speed. Refer to [Speed Control Buttons](#) on page 32.
2. Turn the power on. Refer to [Turning the Power On/Off](#) on page 29.
3. Maneuver the joystick in the following manner:

MOVEMENT	ACTION
FORWARD	Push joystick forward, towards the front of the wheelchair.
REVERSE	Pull joystick back, towards the rear of the wheelchair.
Turn RIGHT	Move joystick toward the right side of the wheelchair.
Turn LEFT	Move joystick toward the left side of the wheelchair.
STOP	Release the joystick and the wheelchair will quickly slow down.

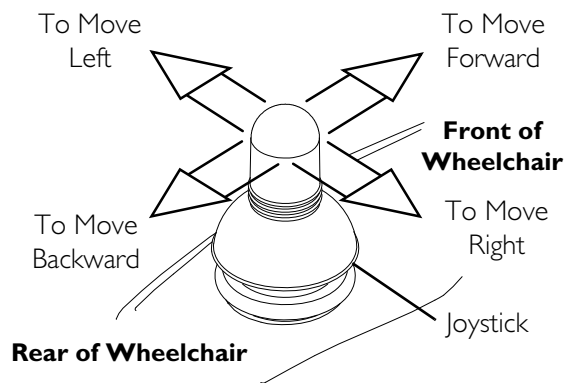
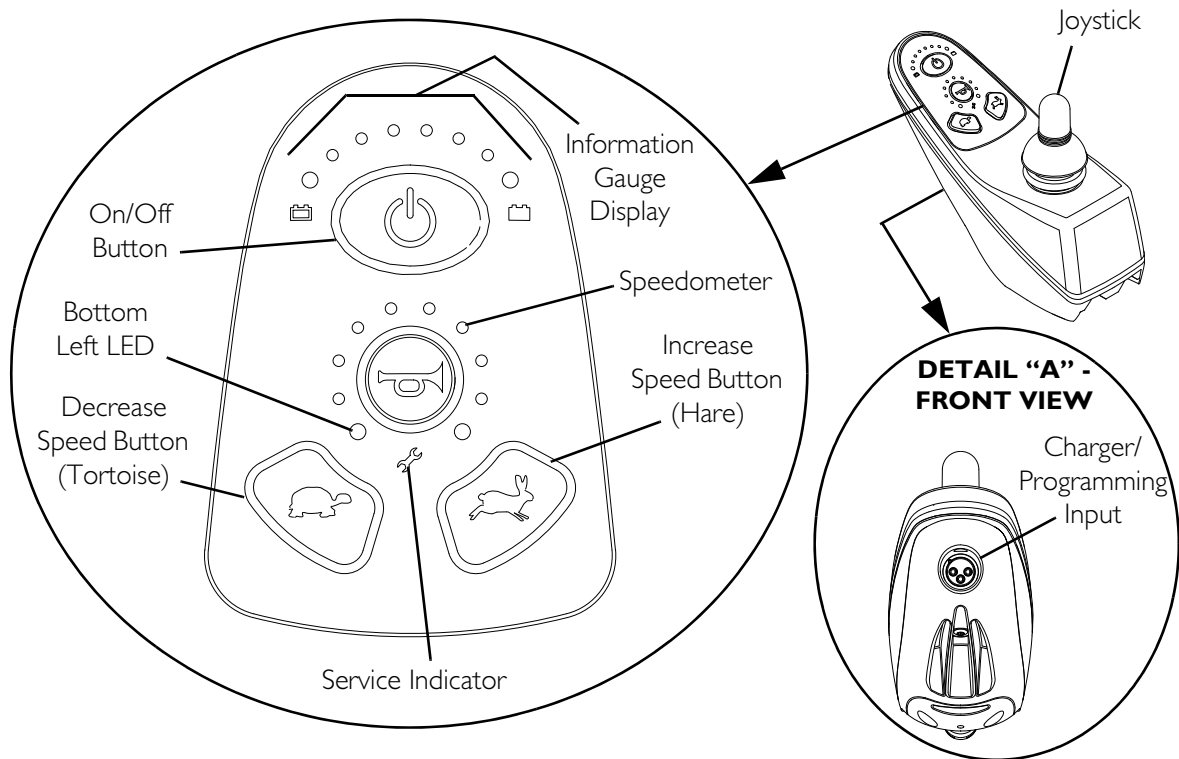

**FIGURE 6.2** Using the Joystick to Drive the Wheelchair

*NOTE: For specific information about the joystick installed on the wheelchair, refer to [MK5 SPI-INT Joystick Switches and Indicators](#) on page 31.*

## MK5 SPJ-INT Joystick Switches and Indicators

NOTE: For the following information, refer to FIGURE 6.3.



**FIGURE 6.3** MK5 SPJ-INT Joystick Switches and Indicators

### On/Off Button

This button is located at the front of the joystick housing. It is used to turn the wheelchair on and off, to remove the joystick from sleep mode (if programmed) and to lock or unlock the joystick (if programmed).

### Speedometer

The speedometer is used to show the maximum speed. The right-most LED indicates current maximum speed setting.

### Speed Control Buttons

The speed control buttons (tortoise button (🐢) and hare button (🐇)) are used to set and adjust the maximum speed.

1. To adjust the speed, perform one of the following:
  - Adjust Speed in 20% Increments (5 Speed Mode) - Press the tortoise button (🐢) or hare button (🐇) to decrease/increase the speed in 20% increments. The larger bars in the speedometer will light.
  - Adjust Speed in Smaller Increments (VSP Mode) - Perform the following steps:
    - i. Press and hold both the tortoise button (🐢) and hare button (🐇) until the joystick beeps.
    - ii. Perform one of the following:
      - Press the tortoise button (🐢) or hare button (🐇) to decrease/increase the speed in 20% increments. The larger bars in the speedometer will light.
      - Press and hold the tortoise button (🐢) or hare button (🐇) to decrease/increase the speed in smaller increments. The smaller bars in the speedometer will light.

### Joystick

The joystick has proportional drive control, meaning that further the joystick is pushed from the upright (neutral) position, the faster the wheelchair moves. Your top speed, however, is limited by the programmed settings.

To slow the wheelchair to a stop, simply release the joystick. The wheelchair has automatic speed and direction compensation to minimize corrections.

### Charger/Programming Input

The charger/programming input is located at the front of the joystick housing. This provides easy access for charging the wheelchair batteries. This port also serves as the Remote Programmer Communication connection. Driving is prevented while the system is charging.

## **Service Indicator**

The AMBER service indicator will light when an error or fault occurs. Refer to Troubleshooting - Electrical on page 29.

## **Information Gauge Display**

Located on the front of the joystick housing, it provides the following information to the user on the status of the wheelchair -

1. Power is on.
2. True state-of-battery-charge, including notification of when the battery requires charging:
  - A. GREEN LEDs - Indicate well charged batteries.
  - B. AMBER LEDs - Indicate batteries are moderately charged. Recharge batteries before taking a long trip.
  - C. RED LEDs - Indicate batteries are running out of charge. Recharge batteries as soon as possible.

The Information Gauge display also serves as a system diagnostic device when a fault is detected by the control module. A specific number of flashes of the LEDs indicate the type of fault detected. Refer to Troubleshooting - Electrical on page 29 for the diagnostic indications of the wheelchair status.

## SECTION 7—ARMS

### ⚠ WARNING

After any adjustments, repair or service and before use, make sure that all attaching hardware is tightened securely - otherwise injury or damage may result.

Before performing any maintenance, adjustment or service verify that On/Off switch on the joystick is in the Off position.

### Removing/Installing the Arms

### ⚠ WARNING

Increasing the width of the arms may affect the overall width of the wheelchair. Ensure that there is enough clearance when attempting to pass through doorways or other tight spaces, otherwise serious injury or damage may result.

*NOTE: For this procedure, refer to FIGURE 7.1.*

*NOTE: Reverse this procedure to install the arms.*

1. Loosen lock knob that secures the arm to the arm support tube.
2. Remove the arm from the arm support tube.
3. If necessary, repeat STEPS 1-2 to remove the other arm.

*NOTE: Semi-Recline Back seat shown. Fold Down Back seats remove/install the same way.*

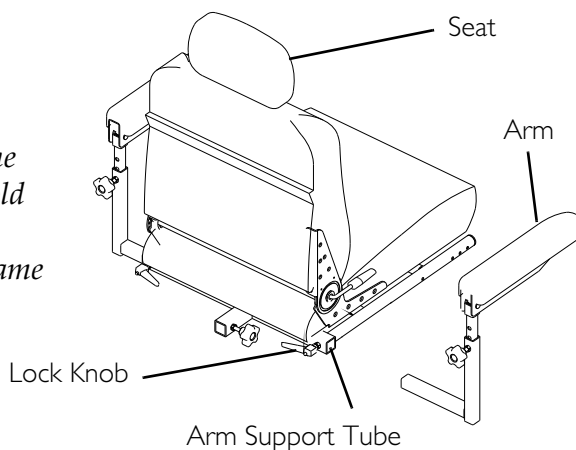

**FIGURE 7.1** Removing/Installing the Arms

## Adjusting the Arms

### Adjusting Width

*NOTE: For this procedure, refer to FIGURE 7.2.*

1. Loosen the two lock knobs that secure the arms to the arm support tube.

*NOTE: Both arms should be adjusted to the same distance away from the arm support tube.*

*NOTE: Changing the width of the arms may also affect the overall width of the wheelchair.*

2. Reposition the arms until desired width is achieved.
3. Securely tighten the two lock knobs that secure the arms to the arm support tube.

*NOTE: Semi-Recline  
Back seat shown. Fold  
Down Back seats adjusts  
the same way.*

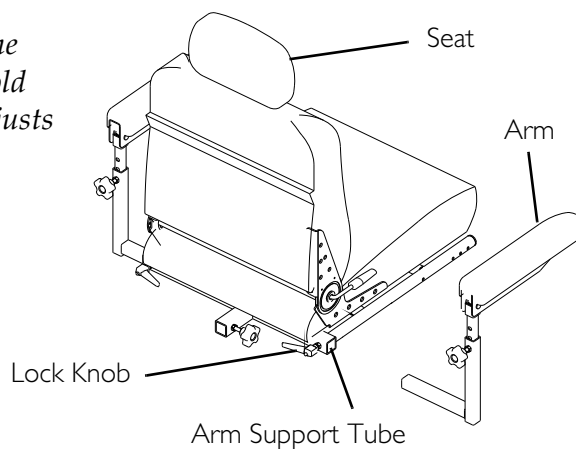

**FIGURE 7.2** Adjusting Width

### Adjusting Angle

#### **⚠ WARNING**

**Pinch point may occur when adjusting the arm angle position.**

*NOTE: For this procedure, refer to FIGURE 7.3.*

1. Lift up the arm pad.
2. Loosen the jam nut.
3. Adjust the socket screw up or down to the desired arm angle position.
4. Tighten the jam nut.
5. To determine the same angle for the opposite arm pad, count the exposed threads after the jam nut has been tightened.
6. Repeat STEPS 1-5 for opposite armrest, if necessary.

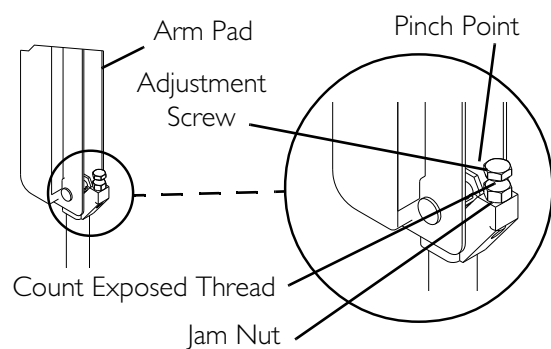
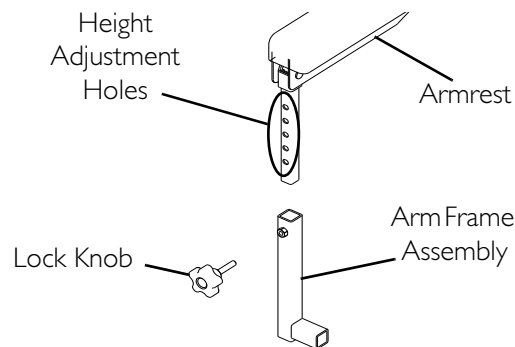

**FIGURE 7.3** Adjusting Angle

### Adjusting Height (Semi-Recline Seats Only)

*NOTE: For this procedure, refer to FIGURE 7.4.*

1. Remove the lock knob that secures the armrest to the arm frame assembly.
2. Adjust the armrest to one of five positions.
3. Reinstall the lock knob that secures the armrest to the arm frame assembly and tighten securely.

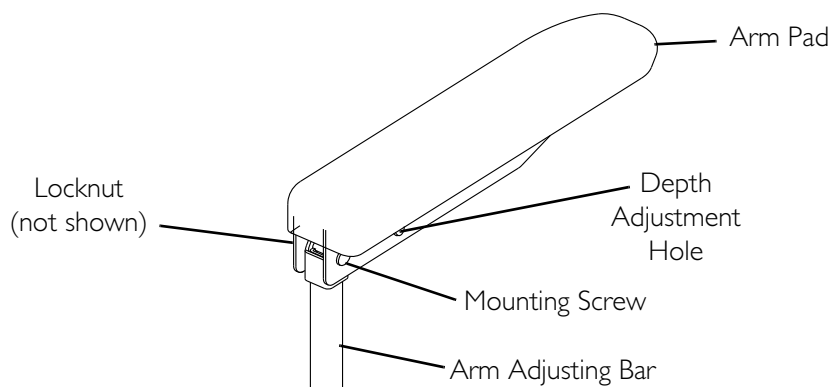

**FIGURE 7.4** Adjusting Height (Semi-Recline Seats Only)

### Adjusting Depth (Fold Down Back Seats Only)

*NOTE: For this procedure, refer to FIGURE 7.5.*

1. Remove the mounting screw and locknut that secure the arm adjusting bar to the arm pad.
2. Install the arm adjusting bar to the other depth adjustment hole on the arm pad with the mounting screw and locknut. Securely tighten.



**FIGURE 7.5** Adjusting Depth (Fold Down Back Seats Only)

## SECTION 8—SEAT

### ⚠ WARNING

After any adjustments, repair or service and before use, make sure that all attaching hardware is tightened securely - otherwise injury or damage may result.

Before performing any maintenance, adjustment or service verify that On/Off switch on the joystick is in the Off position.

## Removing/Installing the Seat Assembly

NOTE: For this procedure, refer to FIGURE 8.1.

### Removing

1. Disconnect the joystick. Refer to Disconnecting/Connecting the Joystick on page 56.
2. Fold down the seat back.
3. Pull the seat lever up and lift the seat assembly up and away from the seat post.

### Installing

1. Align the seat pivot with the seat post
2. Pull the seat lever up and lower the seat assembly on the seat post.

NOTE: If necessary, slightly twist seat assembly back and forth to lock it in place.

3. Release the seat lever.
4. Pull the seat assembly up to ensure that it is locked in place.
5. Connect the joystick. Refer to Disconnecting/Connecting the Joystick on page 56.

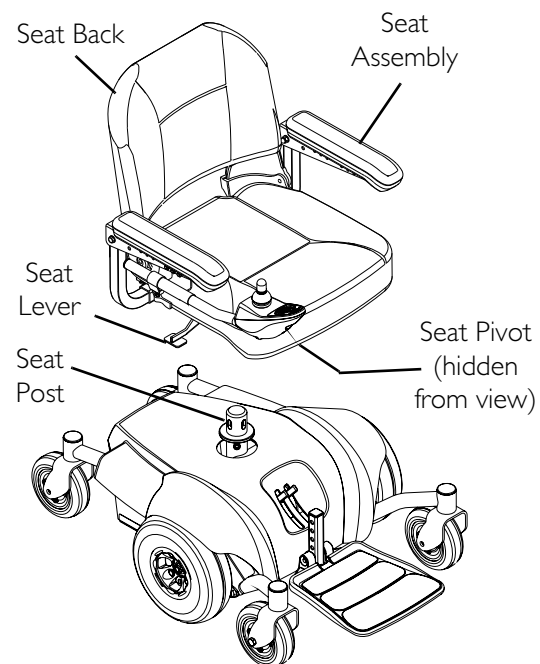
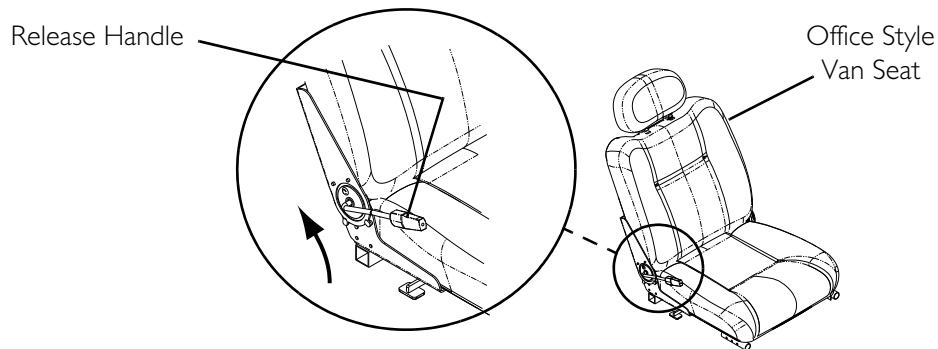

**FIGURE 8.1** Removing/Installing the Seat Assembly

## Adjusting the Back Angle (Semi-Recline Back)

*NOTE: For this procedure, refer to FIGURE 8.2.*

1. Lift up on the release handle and adjust seat to desired angle.
2. Let go of the release handle to lock the back in position.

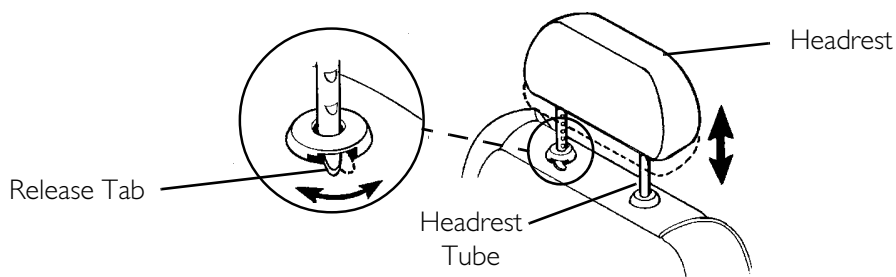

**FIGURE 8.2** Adjusting the Back Angle (Semi-Recline Back)

## Adjusting the Headrest

*NOTE: For this procedure, refer to FIGURE 8.3.*

1. To raise the headrest, lift the headrest up to the desired position.
2. To lower the headrest, push the release tab towards the front of the wheelchair. Lower the headrest to the desired position.



**FIGURE 8.3** Adjusting the Headrest

## Replacing the Seat Positioning Strap

### ⚠ WARNING

**ALWAYS** wear your seat positioning strap.

The seat positioning strap is a positioning belt only. It is not designed for use as a safety device withstanding high stress loads such as auto or aircraft safety belts. If signs of wear appear, belt **MUST** be replaced immediately.

*NOTE: For this procedure, refer to FIGURE 8.4.*

1. Remove the two mounting screws that secure the seat positioning straps to the seat frame.
2. Remove the two halves of the seat positioning strap from the rear seat frame.
3. Reposition the two new seat positioning strap halves underneath seat rails.
4. Reinstall the two mounting screws that secure the seat positioning straps to the seat frame. Securely tighten.

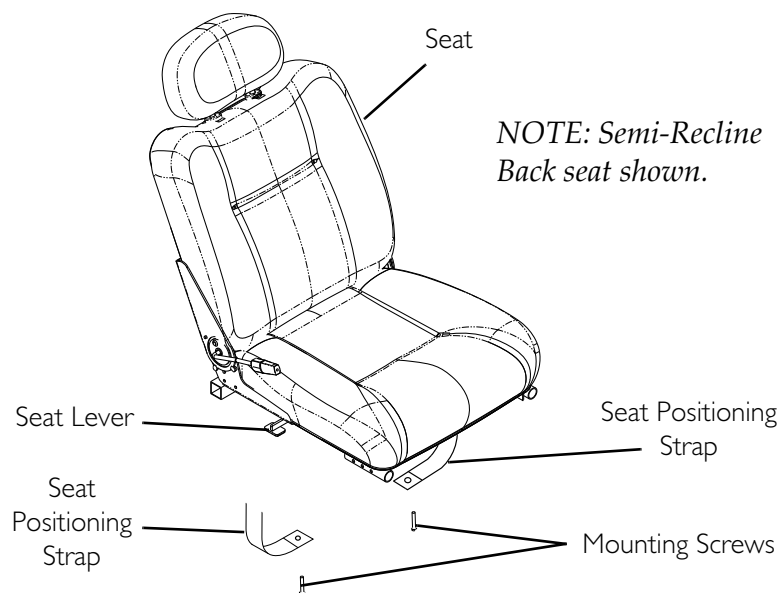

**FIGURE 8.4** Replacing the Seat Positioning Strap

## SECTION 9—FOOTBOARD ASSEMBLY

---

### **⚠ WARNING**

**After any adjustments, repair or service and before use, make sure that all attaching hardware is tightened securely - otherwise injury or damage may result.**

**Before performing any maintenance, adjustment or service verify that on/off switch on the joystick is in the off position.**

**DO NOT stand on the flip-up footboard. When getting in or out of the wheelchair, make sure that the flip-up footboard is in the upward position.**

**Limited Clearance Between Footboard and Caster - The user's feet MUST remain centered on the footboard, away from the footboard sides, while operating the wheelchair. If the user's feet are allowed to rest off the side of the footboard they may come in contact with the caster possibly resulting in injury.**

---

## Removing/Installing the Footboard Assembly

---

### **⚠ WARNING**

**Pinch point may occur when adjusting the footboard.**

---

*NOTE: For this procedure, refer to FIGURE 9.1 on page 41.*

### **Removing**

1. Remove the quick release pin that secures the footboard assembly to the wheelchair frame by depressing the button while sliding the pin out.
2. Remove the footboard assembly from the wheelchair frame.

### **Installing**

---

### **⚠ WARNING**

**Make sure the detent balls of the quick-release pin are fully released beyond the outer edge of the tube before operating the wheelchair. Otherwise, injury and/or damage may result.**

**Keep detent balls clean.**

---

1. Position the footboard assembly onto the wheelchair frame so that the mounting hole in the wheelchair frame aligns with the desired mounting hole in the footboard assembly.
  2. Install the quick release pin by depressing the button while sliding the pin in. Ensure that the detent balls are engaged with the outer edge of the tube (Detail "A" of FIGURE 9.1).
-

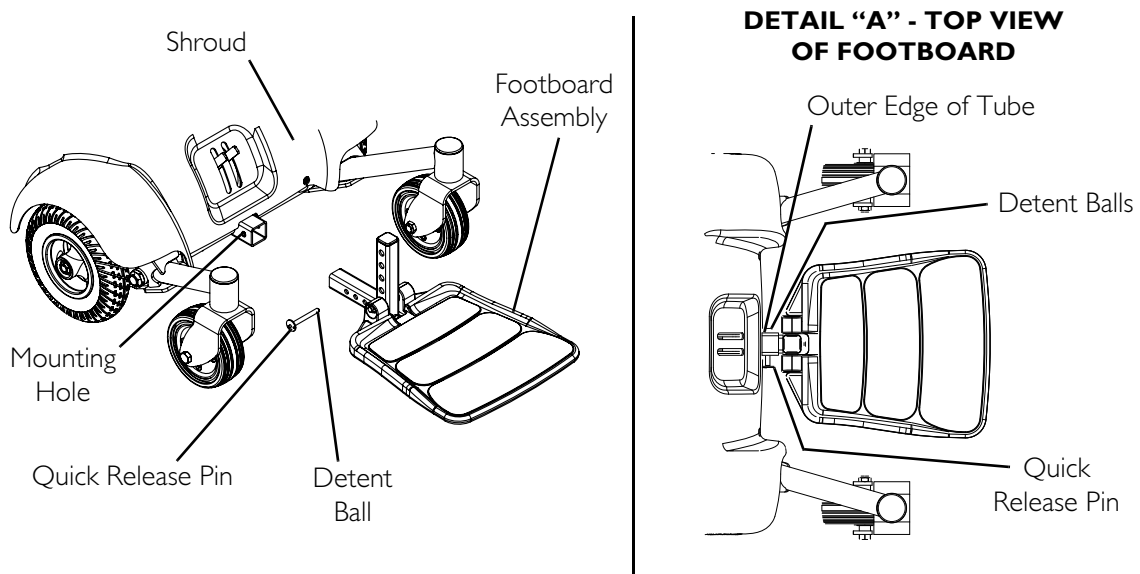

**FIGURE 9.1** Removing/Installing the Footboard Assembly

## Adjusting the Footboard Assembly

### Angle

*NOTE: For this procedure, refer to FIGURE 9.2.*

1. Loosen the jam nut and set screw located underneath on the backside of the footplate.
2. Adjust the set screw in or out to obtain the desired footboard assembly angle.
3. Thread the jam nut and washer inward until it is flush with the footboard bracket.
4. Securely tighten the jam nut and washer to secure the mounting screw in place.

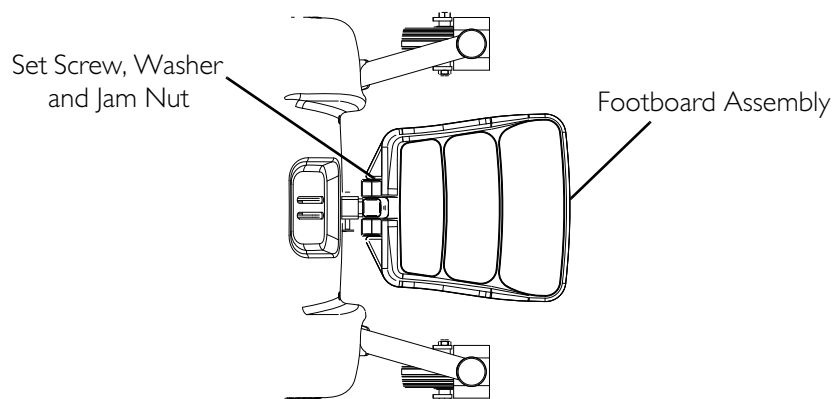

**FIGURE 9.2** Adjusting the Footboard Assembly - Angle

## Depth

*NOTE: For this procedure, refer to FIGURE 9.3.*

1. Remove the quick release pin that secures the footboard assembly to the wheelchair frame.

---

### **⚠ WARNING**

**Make sure the detent balls of the quick-release pin are fully released beyond the outer edge of the tube before operating the wheelchair. Otherwise, injury and/or damage may result.**

**Keep detent balls clean**

---

2. Adjust footboard to one of three mounting positions.
3. Install the quick release pin. Make sure the detent balls are engaged with the outer edge of the tube (Detail "A" of FIGURE 9.3).

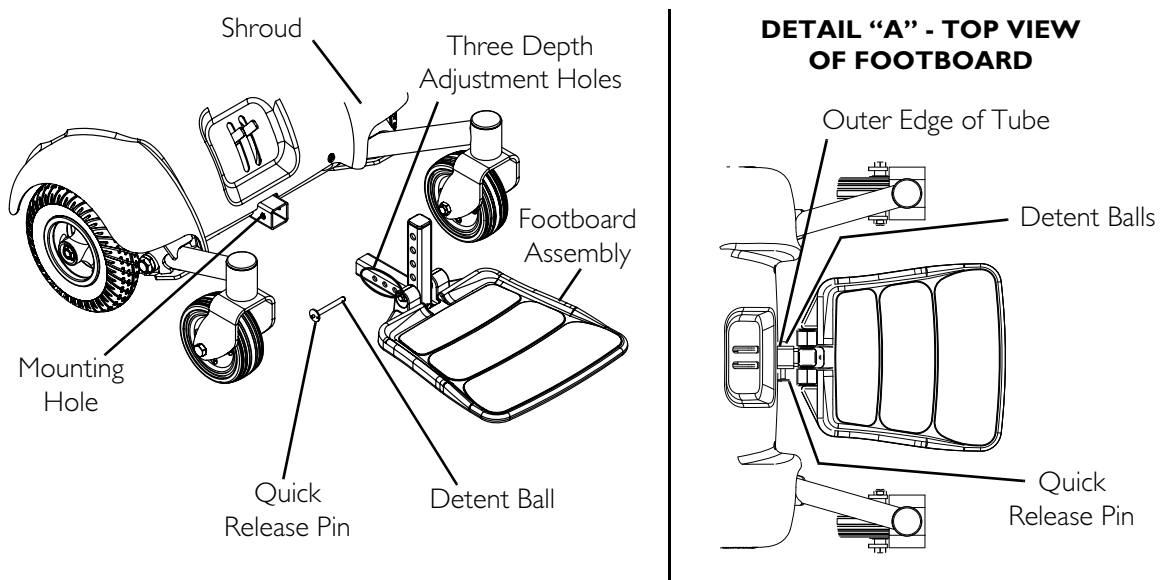
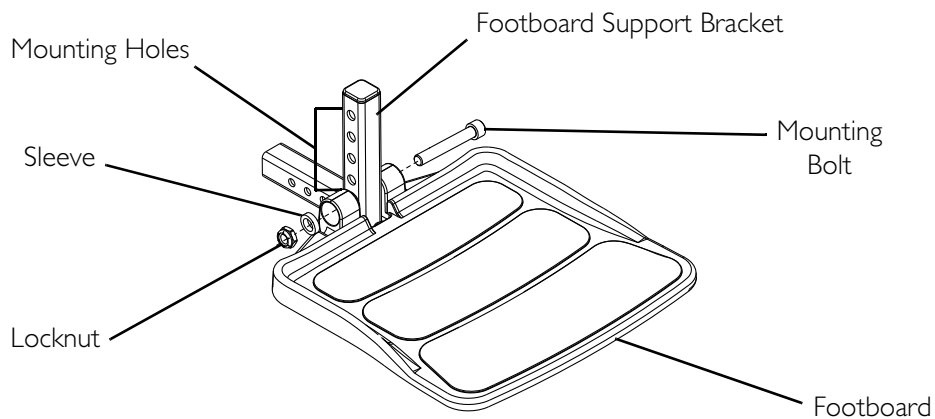

**FIGURE 9.3** Adjusting the Footboard Assembly - Depth

## Height

*NOTE: For this procedure, refer to FIGURE 9.4.*

1. Remove the quick release pin that secures the footboard assembly to the wheelchair frame.
2. Remove the mounting bolt, sleeve, and locknut that secures the footboard to footboard support bracket.
3. Align the footboard to one of the mounting holes on the footboard support bracket.
4. Secure the footboard to the footboard support bracket with the mounting bolt, sleeve and locknut. Securely tighten.



**FIGURE 9.4** Adjusting the Footboard Assembly - Height

## SECTION 10—FRONT RIGGINGS

### ⚠ WARNING

After any adjustments, repair or service and before use, make sure that all attaching hardware is tightened securely - otherwise injury or damage may result.

While the wheelchair is moving, minimum ground clearance for the front rigging is three inches. If the wheelchair is not moving, the front rigging **MUST** maintain a minimum of one inch ground clearance - otherwise personal injury and damage may result.

**DO NOT** stand on the front riggings, otherwise damage may occur. When getting in or out of the wheelchair, make sure that the footplates on the front riggings are in the upward position or moved out of the way.

Before performing any maintenance, adjustment or service verify that On/Off switch on the joystick is in the Off position.

## Installing/Removing Front Riggings

### CAUTION

If front riggings are used, then the seat **MUST** be adjusted to the highest mounting position - otherwise damage may occur.

*NOTE: For this procedure, refer to FIGURE 10.1.*

### Installing

1. If necessary, remove the footboard. Refer to Removing/Installing the Footboard Assembly on page 40.
2. Turn front rigging to the side (open footplate is perpendicular to wheelchair) and position mounting holes in the front rigging hinge plates with hinge pins on the wheelchair frame.
3. Install the front rigging hinge plates onto the hinge pins on the wheelchair frame.
4. Push the front rigging towards the inside of the wheelchair until it locks into place.

*NOTE: The footplate will be on the inside of the wheelchair when locked in place.*

5. Repeat STEPS 1-4 for opposite side of wheelchair.

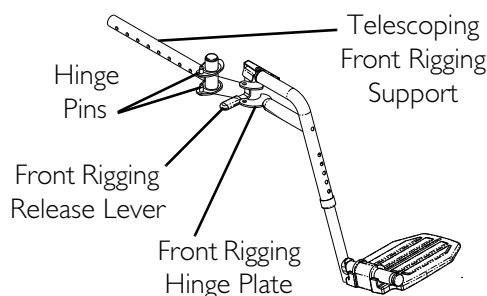

**FIGURE 10.1** Installing/Removing Front Riggings

## Removing

1. Push the front rigging release lever inward and rotate the footrest out.
2. Lift up on front rigging and remove from the wheelchair.
3. Repeat STEPS 1-2 for opposite side of wheelchair.

## Adjusting Footrest Height

### Model PHWH93

*NOTE: For this procedure, refer to FIGURE 10.2.*

1. Remove any accessories from the footrest(s).
2. Remove the footrest from the wheelchair. Refer to [Installing/Removing Front Riggings](#) on page 44.

*NOTE: Lay footrest on a flat surface to simplify section.*

3. Remove the hex bolt, coved washers and locknut that secure the lower footrest to the footrest support.
4. Reposition the lower footrest to the desired height.
5. Reinstall hex bolt, coved washers and locknut that secure lower footrest to footrest support. Tighten securely.
6. Repeat STEPS 1-5 for the opposite side of the wheelchair footrest, if necessary.
7. Reinstall the footrest(s) onto the wheelchair. Refer to [Installing/Removing Front Riggings](#) on page 44.
8. Reinstall any accessories onto the footrest(s).

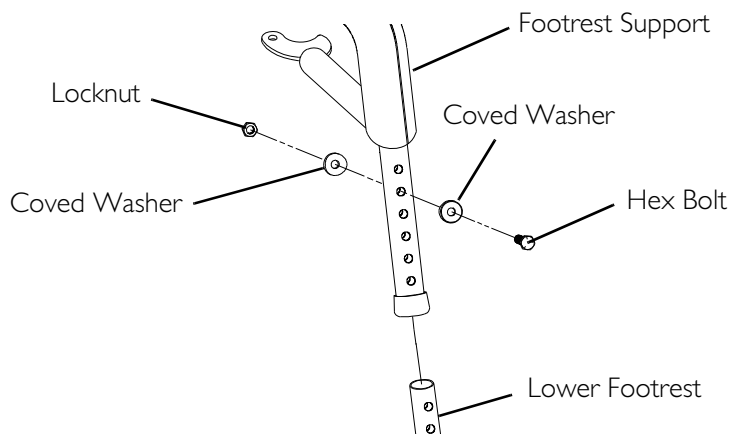

**FIGURE 10.2** Adjusting Footrest Height - Model PHWH93

**Model PH904A and PHAL4A**

*NOTE: For this procedure, refer to FIGURE 10.3.*

*NOTE: PH904A style front rigging shown. PHAL4A front rigging adjust the same way.*

1. Loosen, but do not remove the lug bolt and locknut that secure the lower footrest to the footrest support.
2. Reposition the lower footrest to the desired height.
3. Securely tighten the lug bolt and locknut that secure the lower footrest to the footrest support.
4. Repeat STEPS 1-3 for the opposite side of the wheelchair footrest, if necessary.

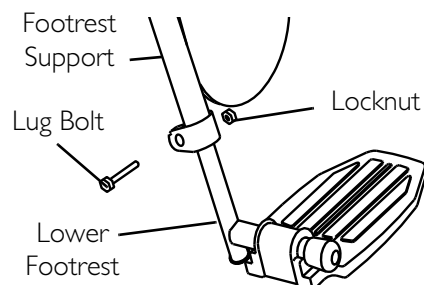
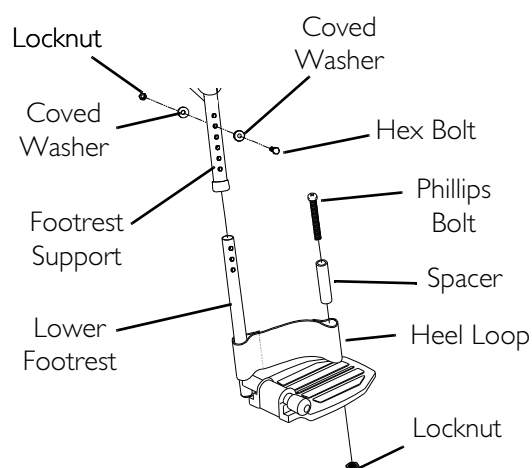

**FIGURE 10.3** Adjusting Footrest Height - Model PH904A and PHAL4A

**Replacing Heel Loops**

*NOTE: For this procedure, refer to FIGURE 10.4.*

1. Note the position of hex bolt, covered washers and locknut for reinstallation.
2. Remove the hex bolt, covered washers and locknut that secure the lower footrest to the footrest support.
3. Remove the lower footrest.
4. Remove the phillips® bolt, spacer and locknut that secure the existing heel loop to the lower footrest.
5. Slide the existing heel loop off the lower footrest.
6. Replace heel loop.
7. Reverse STEPS 1-6 to reassemble.



**FIGURE 10.4** Replacing Heel Loops

*NOTE: When securing heel loop to lower footrest, tighten the phillips screw and locknut until the spacer is secure.*

## Raising/Lowering Elevating Front Riggings

*NOTE: For this procedure, refer to FIGURE 10.5.*

1. Perform one of the following:
  - Raising - Pull back on the release lever and raise front rigging to the desired height.
  - Lowering - Support front rigging with one hand away from the release lever. Push release lever downward with other hand.

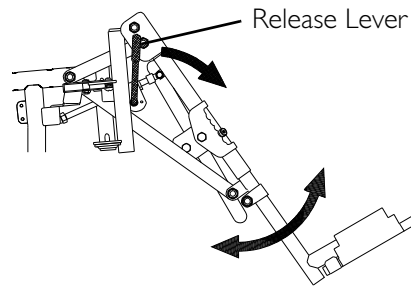

**FIGURE 10.5** Raising/Lowering Elevating Front Riggings

## Adjusting/Replacing Telescoping Front Rigging Supports

*NOTE: For this procedure, refer to FIGURE 10.6 on page 48.*

*NOTE: When adjusting the telescoping front rigging support depth, ensure the footplate does not interfere with the caster wheel rotation.*

*NOTE: Telescoping front rigging supports may be extended up to 2 inches from the wheelchair frame in 1-inch increments. This adjustment does not affect seat depth.*

*NOTE: When installing the front riggings support tubes, ensure that the hinge pins are on the outside of the chair facing away from the seat frame.*

1. Remove the seat. Refer to [Removing/Installing the Seat Assembly](#) on page 37.
2. Remove the two socket bolts and locknuts that secure telescoping front rigging support to the seat frame.
3. Perform one of the following:
  - Adjusting - Align the appropriate mounting hole of the telescoping front rigging support with the front mounting hole in the seat frame tubes to achieve the desired depth as shown in FIGURE 10.6.
  - Replacing -
    - i. Remove the existing telescoping front rigging support from the wheelchair frame.
    - ii. Insert the new telescoping front rigging support into the seat frame.
    - iii. Align the appropriate mounting hole of the telescoping front rigging support with the front mounting hole in the seat frame tubes to achieve the desired depth as shown in FIGURE 10.6.

## SECTION 10—FRONT RIGGINGS

*NOTE: The footplate will be on the inside of the wheelchair when locked in place.*

4. Using the two socket bolts and locknuts, secure the telescoping front rigging support to the seat frame as shown in FIGURE 10.6.
5. If necessary, repeat STEPS 2-4 on remaining telescoping front rigging support.
6. Reinstall the seat. Refer to Removing/Installing the Seat Assembly on page 37.

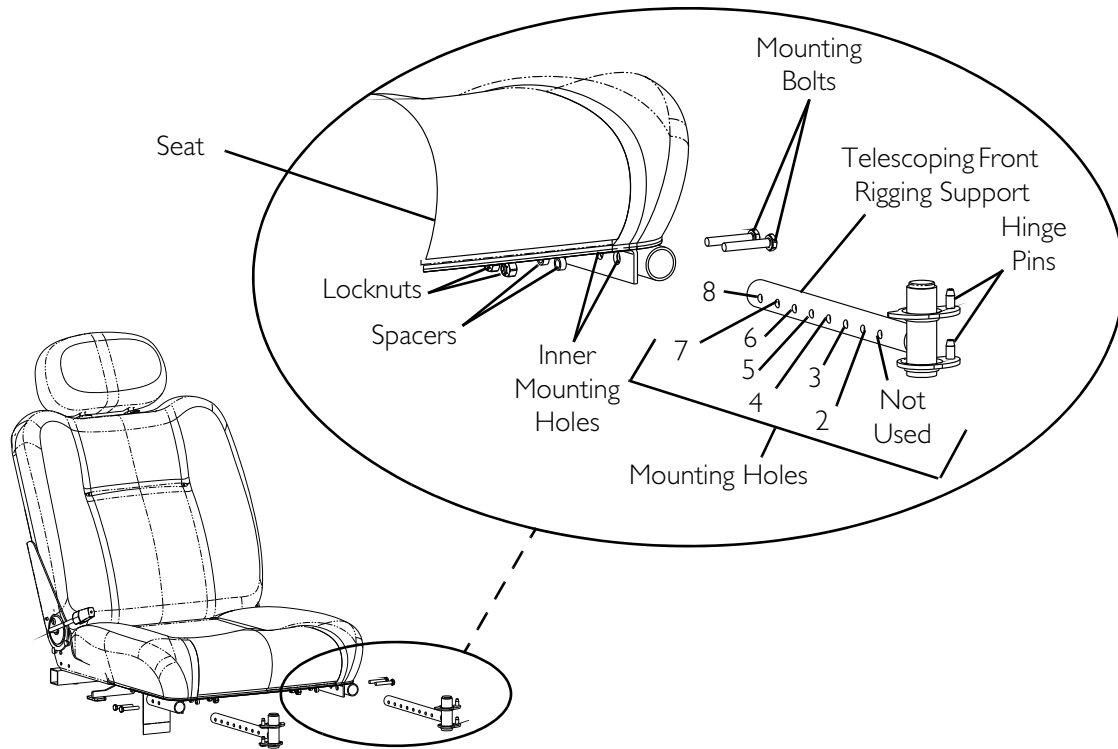

FRONT RIGGING MODEL	STANDARD POSITION		1 INCH OUT		2 INCHES OUT	
	18 inches wide	20 inches wide	18 inches wide	20 inches wide	18 inches wide	20 inches wide
PHW93	Holes 4 and 5	Holes 4 and 5	Holes 5 and 6	Holes 5 and 6	Holes 6 and 7	Holes 6 and 7
PH904A and PHAL4A	Holes 3 and 4	Holes 3 and 4	Holes 4 and 5	Holes 4 and 5	Holes 5 and 6	Holes 5 and 6

**FIGURE 10.6** Adjusting/Replacing Telescoping Front Rigging Supports

---

# SECTION 11—SHROUD AND WHEELS

---

## **⚠ WARNING**

**After any adjustments, repair or service and before use, make sure that all attaching hardware is tightened securely - otherwise injury or damage may result.**

**Before performing any maintenance, adjustment or service verify that on/off switch on the joystick is in the off position.**

---

## Replacing the Flat Free Tires on the Wheel Rim

---

### **⚠ WARNING**

**DO NOT attempt to replace flat free tires. This procedure MUST be performed by a qualified technician.**

---

*NOTE: During initial use of the wheelchair, the user may experience flat spots on the wheels. Flat spots will vanish with continued use of the wheelchair.*

## Removing/Installing the Top Shroud

*NOTE: For this procedure, refer to FIGURE 11.1 on page 50.*

*NOTE: The top shroud cannot be completely removed from the wheelchair without disconnecting the joystick cable. If it is necessary, refer to [Disconnecting/Connecting the Joystick](#) on page 56 to remove the top shroud from the wheelchair.*

### Removing

1. Remove the seat. Refer to [Removing/Installing the Seat Assembly](#) on page 37.
2. Remove the four mounting screws that secure the top shroud to the wheelchair frame.

### Installing

1. If necessary connect the joystick cable to the batteries and or the right and left motors.
2. Position the top shroud onto the wheelchair frame.
3. Using the four mounting screws, secure the top shroud to the wheelchair frame.
4. Install the seat. Refer to [Removing/Installing the Seat Assembly](#) on page 37.

## Removing/Installing the Rear Shroud

*NOTE: For this procedure, refer to FIGURE 11.1.*

### Removing

1. Remove the two screws that secure the rear shroud to the frame.
2. Remove the rear shroud.

### Installing

1. Insert the tabs at the bottom of the rear shroud into the slots in the bottom of the frame.
2. Secure the rear shroud to the frame using the two screws. **DO NOT** overtighten.

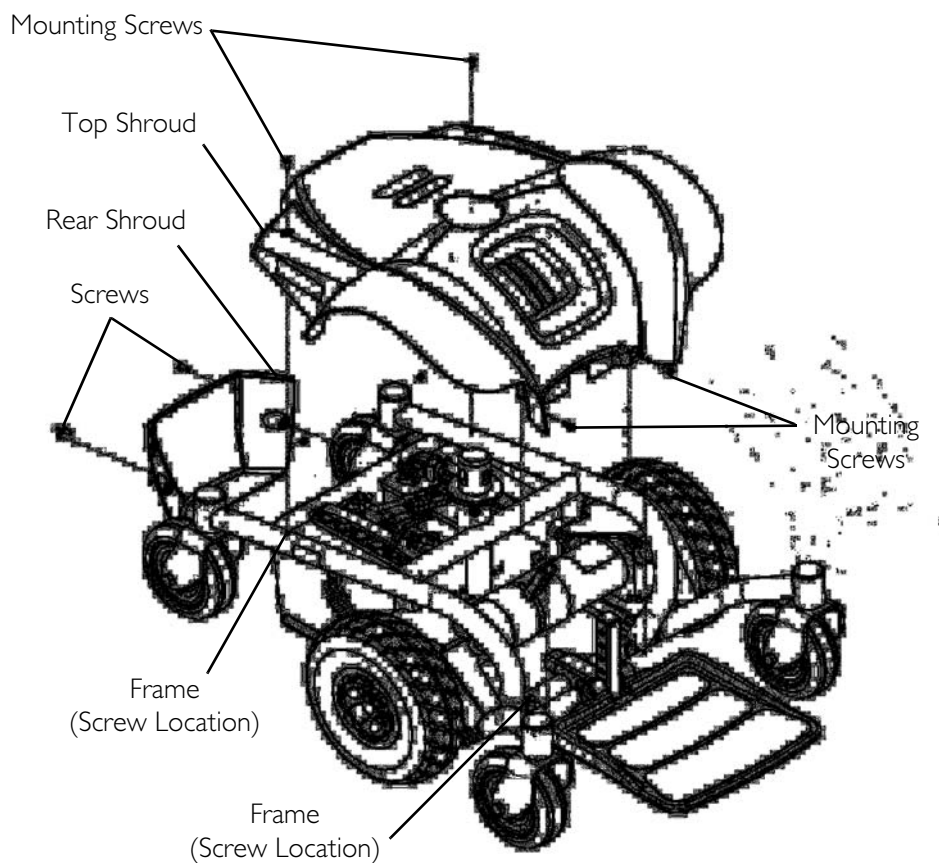

**FIGURE 11.1** Removing/Installing the Top Shroud - Removing/Installing the Rear Shroud

## Engaging/Disengaging Motor Release Lever

### ⚠ WARNING

**DO NOT** engage or disengage the motor release lever until the On/Off switch on the joystick is in the Off position.

### CAUTION

**Ensure both motor release levers are fully engaged before driving the wheelchair**

*NOTE: For this procedure, refer to FIGURE 11.2 on page 51.*

*NOTE: The motor lock disengagement/engagement allows freewheeling or joystick controlled operation. Freewheeling allows an attendant to maneuver the wheelchair without power.*

1. Locate the motor release handles on the motors protruding through the shroud on the front of the wheelchair behind the footboard.
2. Perform one of the following:
  - To Disengage the Motor Release Levers - Push the motor lock lever down.

*NOTE: This allows the wheelchair to freewheel for pushing, if necessary.*

*NOTE: It may be necessary to rock the wheels slightly until the motor release lever disengages.*

- To Engage the Motor Release Levers - Pull the motor lock handles up.

*NOTE: This allows the motors to drive the wheels.*

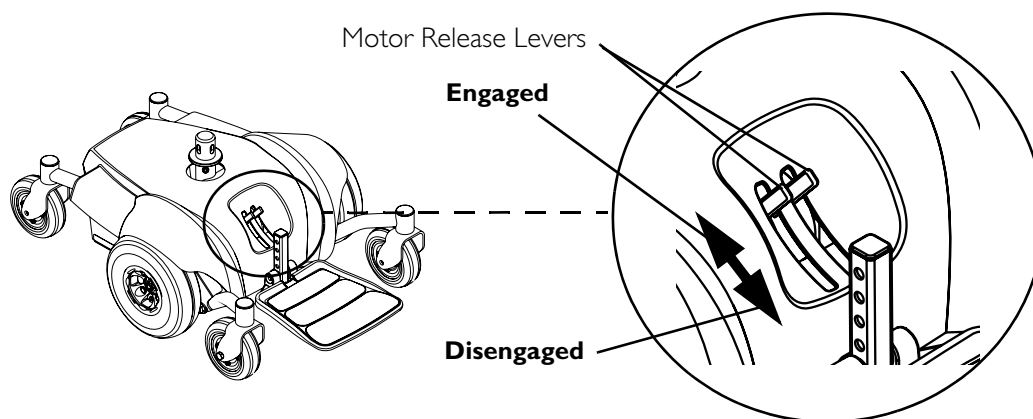

**FIGURE 11.2** Engaging/Disengaging Motor Release Lever

## Removing/Installing Casters

*NOTE: For this procedure, refer to FIGURE 11.3.*

*NOTE: Front and rear casters are replaced in the same manner.*

Periodically, the tires will need to be replaced due to wear or puncture.

## Removing

1. Remove the mounting screw, two spacers and locknut that secure the existing caster to the fork.
2. Remove the existing caster from the fork.

## Installing

1. Position the new/existing caster into the fork.
2. Reinstall the mounting screw, two spacers and locknut. Securely tighten.
3. Torque locknut to 10 ft-lbs (120 in-lbs).
4. Loosen the locknut 1/8 of a turn.
5. Move the caster side to side.

*NOTE: If the caster moves side to side, tighten the locknut slightly. Repeat STEP 4 until there is no side to side movement of the caster.*

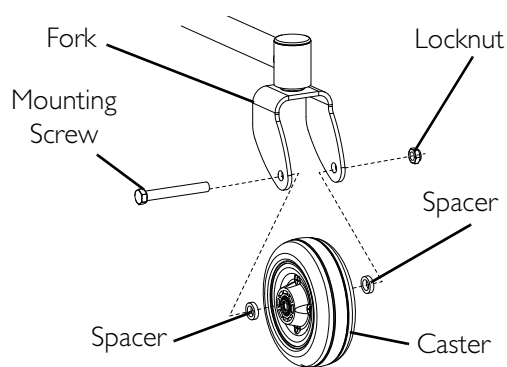

**FIGURE 11.3** Removing/Installing Casters

## Adjusting Forks

*NOTE: For this procedure, refer to FIGURE 11.4.*

1. Remove the headtube cap.
2. To properly tighten caster assembly and guard against flutter, perform the following check:
  - A. Tip back the wheelchair.
  - B. Pivot both forks and casters to top of their arc simultaneously.
  - C. Let casters drop to bottom of arc (casters should swing once to one-side, then immediately rest in a straight downward position).
  - D. Adjust locknut according to freedom of caster swing.
  - E. Test wheelchair for maneuverability.
  - F. Readjust locknut if necessary, and repeat STEPS 2-3 until correct.
  - G. Replace headtube cap.

*NOTE: Components exploded for clarity. There is no need to remove the fork from the base frame.*

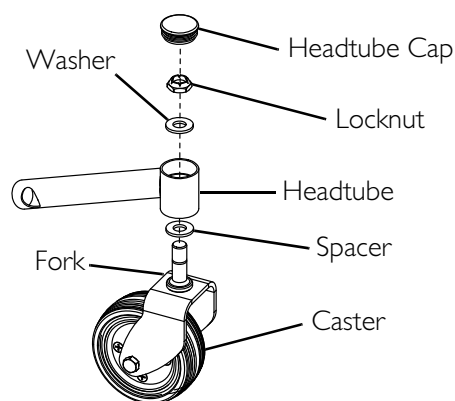

**FIGURE 11.4** Adjusting Forks

## Removing/Installing Forks and/or Caster Assemblies

*NOTE: For this procedure, refer to FIGURE 11.4.*

*NOTE: Front and rear forks are replaced in the same manner.*

### Removing

1. Remove the caster from the fork if necessary. Refer to [Removing/Installing Casters](#) on page 51.
2. Remove the head tube cap.
3. Remove locknut, washer and spacer securing the fork to the headtube.

### Installing

1. Insert threaded post of fork into headtube.

*NOTE: Check the bearing assemblies. Replace if necessary.*

2. Slide the fork completely into headtube.
3. Secure fork to headtube with locknut, washer, and spacer. Secure tightly.

---

### **⚠ WARNING**

**Improper positioning of the washer will prohibit the free movement of the forks which may result in injury to the occupant.**

---

4. Install the caster onto the fork if removed. Refer to [Removing/Installing Casters](#) on page 51.
5. Install headtube cap.

## Adjusting Anti-Dive Springs

---

### **⚠ WARNING**

**DO NOT attempt to replace or adjust the anti-dive springs. This procedure MUST be performed by a qualified technician.**

---

*NOTE: The anti-dive springs may be adjusted accordingly to users weight.*

## SECTION 12—ELECTRONICS

---

### **⚠ WARNING**

**After any adjustments, repair or service and before use, make sure that all attaching hardware is tightened securely - otherwise injury or damage may result.**

**Before performing any maintenance, adjustment or service verify that On/Off switch on the joystick is in the Off position.**

---

### **Removing/Installing the Joystick Assembly**

*NOTE: For this procedure, refer to FIGURE 12.1 on page 55.*

#### **Removing**

1. Remove the tie-wraps securing the joystick cable to the joystick mounting tube and arm.
2. Turn the adjustment lock lever to release the joystick mounting tube from the mounting bracket.
3. Remove the joystick assembly from the mounting bracket.

*NOTE: The joystick mounting tube and joystick will remain connected to the wheelchair base by the joystick cable. If necessary to remove the joystick assembly from the wheelchair base disconnect the joystick cable the wheelchair base. Refer to Disconnecting/Connecting the Joystick on page 56.*

#### **Installing**

*NOTE: If necessary, connect the joystick cable to the wheelchair base before installing the joystick assembly. Refer to Disconnecting/Connecting the Joystick on page 56.*

1. Slide joystick mounting tube through the mounting bracket to the desired position.
2. Tighten the adjustment lock lever to secure the joystick mounting tube to the mounting bracket on the other arm.
3. Using the tie-wraps, secure the joystick cable to the arm (Detail "A").

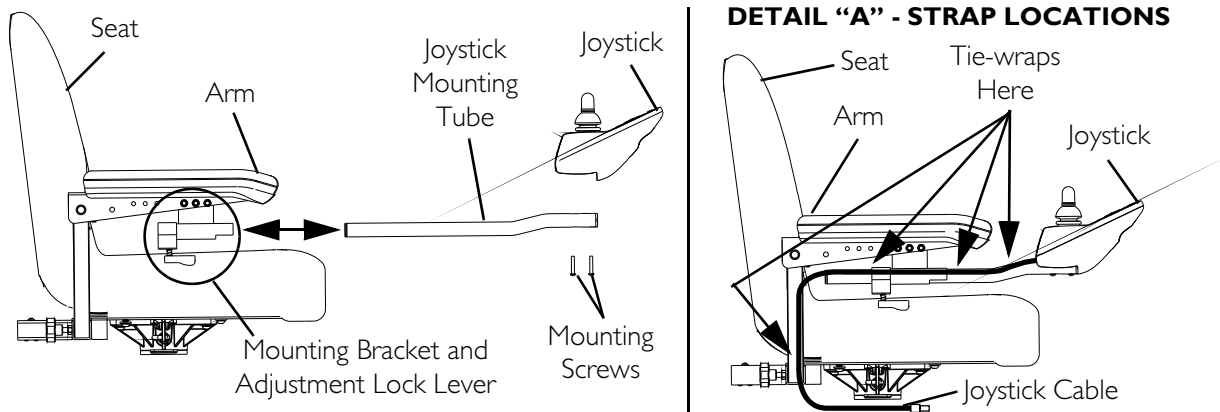

**FIGURE 12.1** Removing/Installing the Joystick Assembly

## Repositioning the Joystick

*NOTE: For this procedure, refer to FIGURE 12.2.*

*NOTE: Take note of position and orientation of mounting hardware for reinstalling the joystick assembly.*

1. Remove the joystick assembly from the wheelchair. Refer to Removing/Installing the Joystick Assembly on page 54.
2. Remove the three hex mounting screws, spacers and locknuts that secure the mounting bracket to the three mounting holes on the arm frame.

*NOTE: The mounting bracket is mounted to the inside of the arm frame.*

3. Reposition the mounting bracket on the opposite arm frame.
4. Using the three hex mounting screws, spacers and locknuts secure the mounting bracket to the three mounting holes of the arm frame.
5. If necessary, perform the following to reposition the adjustment lock:
  - A. Slide the adjustment lock from the mounting bracket.
  - B. Rotate adjustment lock 180° and slide adjustment lock over the opposite end of the mounting bracket.
6. Reinstall the joystick assembly onto the wheelchair. Refer to Removing/Installing the Joystick Assembly on page 54.

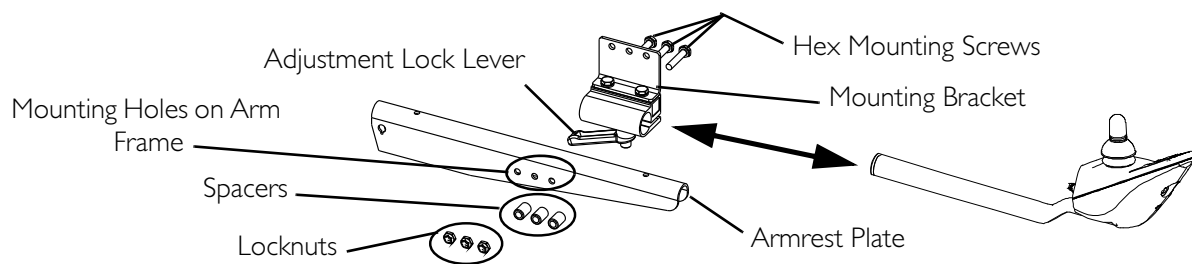

**FIGURE 12.2** Repositioning the Joystick

## Disconnecting/Connecting the Joystick

*NOTE: For this procedure, refer to FIGURE 12.3 on page 57 and FIGURE 11.1 on 50.*

### Disconnecting the Joystick

1. Remove the joystick assembly from the wheelchair arm. Refer to Removing/Installing the Joystick Assembly on page 54.
2. Remove the seat. Refer to Removing/Installing the Seat Assembly on page 39.
3. Remove the tie-wrap securing the joystick cable to the seat post.
4. Remove the four mounting screws securing the top shroud to the wheelchair frame (FIGURE 11.1).
5. Lifting up, move the top shroud away from the wheelchair frame enough to access the joystick cable connectors.
6. Disconnect the battery connector and the right and left motor connectors from the joystick cable connectors (Detail "A" of FIGURE 12.3).
7. Pull the joystick cable connectors through the top shroud opening.

### Connecting the Joystick

---

**⚠ WARNING**

**The joystick connectors fit together in one way only. DO NOT force them together.**

---

1. If necessary, remove the top shroud. Refer to Removing/Installing the Top Shroud on page 49.
2. Insert the joystick cable connectors through the hole of the top shroud.
3. Connect the battery connector and the right and left motor connectors to the joystick cable connectors.
4. Position the top shroud onto the wheelchair frame.
5. Using the four mounting screws, secure the top shroud to the wheelchair frame (FIGURE 11.1).
6. Install the seat. Refer to Removing/Installing the Seat Assembly on page 39.
7. Install the joystick assembly onto the wheelchair arm. Refer to Removing/Installing the Joystick Assembly on page 54.

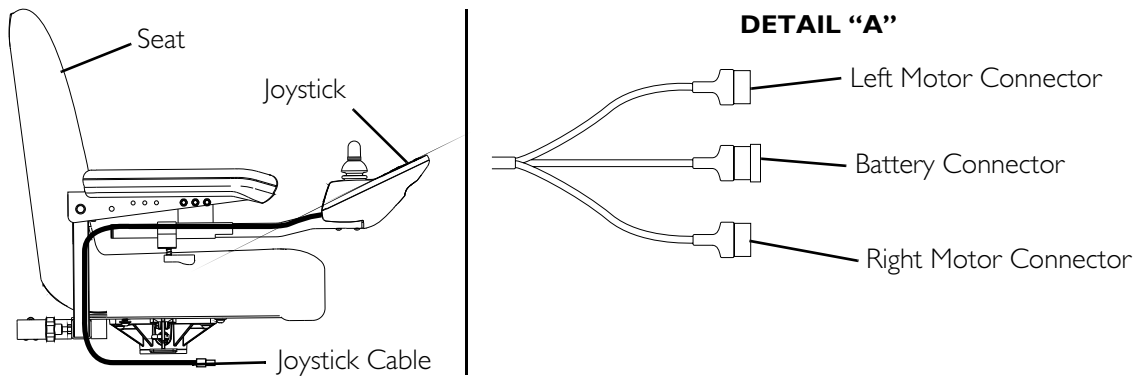

**FIGURE 12.3** Disconnecting/Connecting the Joystick

## SECTION 13—BATTERIES

### Warnings For Handling and Replacing Batteries

---

#### **⚠ WARNING**

After any adjustments, repair or service and before use, make sure that all attaching hardware is tightened securely - otherwise injury or damage may result.

Before performing any maintenance, adjustment or service verify that On/Off switch on the joystick is in the Off position.

Most batteries are not sold with instructions. However, warnings are frequently noted on the cell caps. Read them carefully, otherwise serious injury or damage may occur.

Invacare strongly recommends that battery installation and battery replacement **ALWAYS** be done by a qualified technician.

**ALWAYS** transport the battery pack/box in an upright and secure manner. To prevent damage, do not transport the battery pack/box with other objects that could suddenly shift during transportation, unless they are secured or in a different vehicle area. **DO NOT** transport battery pack/box with gas cans or similar containers in the same vehicle area.

**DO NOT** tip the batteries. Keep the batteries in an upright position.

**NEVER** allow any of your tools and/or battery cable(s) to contact both battery posts at the same time. An electrical short may occur and serious personal injury or damage may occur.

The **POSITIVE (+) RED** battery cable must connect to the **POSITIVE (+)** battery terminal, otherwise serious damage will occur to the electrical system.

---

*NOTE: If there is battery acid in the bottom of the battery tray or on the sides of the battery(ies), apply baking soda to these areas to neutralize the battery acid. Before reinstalling the existing or new battery(ies), clean the baking soda from the battery tray or battery(ies) being sure to avoid contact with skin and eyes. Determine source of contamination. Never install/reinstall a battery with a cracked or otherwise damaged case.*

### Using the Proper Batteries

1. Place battery on ground/flat surface.
2. Visually draw a horizontal and vertical centerline through the middle of battery.
3. Position the battery so that the terminals are above the horizontal centerline.
4. Visually inspect the battery to ensure the correct position of the POSITIVE and NEGATIVE terminals.

**⚠ WARNING**

**Batteries with terminal configuration as shown below **MUST** be used. Batteries that have the reverse terminal configuration **MUST NOT** be used - otherwise injury and damage may occur.**

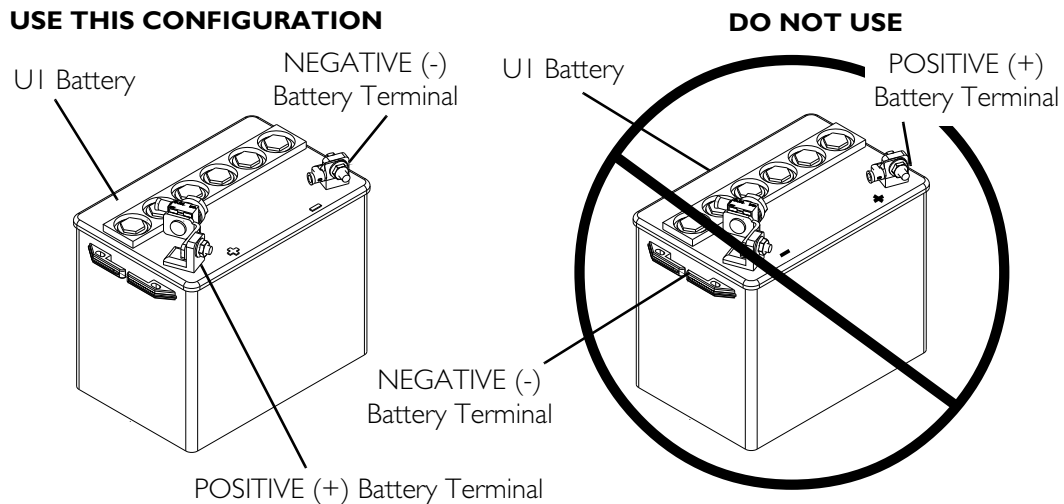

*NOTE: Recommended battery type is spill proof and requires no maintenance except routine charging.*

*NOTE: Charge batteries daily. DO NOT allow batteries to completely discharge. To charge batteries, refer to Charging Batteries on page 63.*

*NOTE: Invacare recommends that both batteries be replaced if one battery is defective.*

## Removing/Installing the Batteries

*NOTE: For this procedure, refer to FIGURE 13.1 on page 60.*

**⚠ WARNING**

**Install protective caps on POSITIVE (+) and NEGATIVE (-) terminals.**

**All battery terminal covers (two on the right battery and two on the left battery) **MUST** be installed prior to use.**

### Removing

1. Disconnect the joystick. Refer to Disconnecting/Connecting the Joystick on page 56.
2. Remove the seat. Refer to Removing/Installing the Seat Assembly on page 37.
3. Remove the top shroud. Refer to Removing/Installing the Top Shroud on page 49.
4. Disconnect the right battery from the controller (BLACK connector).

5. Disconnect the left battery from the right battery (RED and BLACK connectors).
6. Lift left and right battery out of the battery tray using the battery handles.

### Installing

1. Verify the joystick On/Off switch is in the Off position and disconnect joystick cable. Refer to Disconnecting/Connecting the Joystick on page 56.

2. Position the right battery in the battery tray.

3. Position left battery in the battery tray.

*NOTE: Ensure that both batteries are properly seated and resting on the battery tray.*

4. Connect the left battery to the right battery (RED and BLACK connectors).

5. Connect the right battery to the controller (BLACK connector).

6. Install the top shroud. Refer to Removing/Installing the Top Shroud on page 49.

7. Install the seat. Refer to Removing/Installing the Seat Assembly on page 37.

8. Connect the joystick cable. Refer to Disconnecting/Connecting the Joystick on page 56.

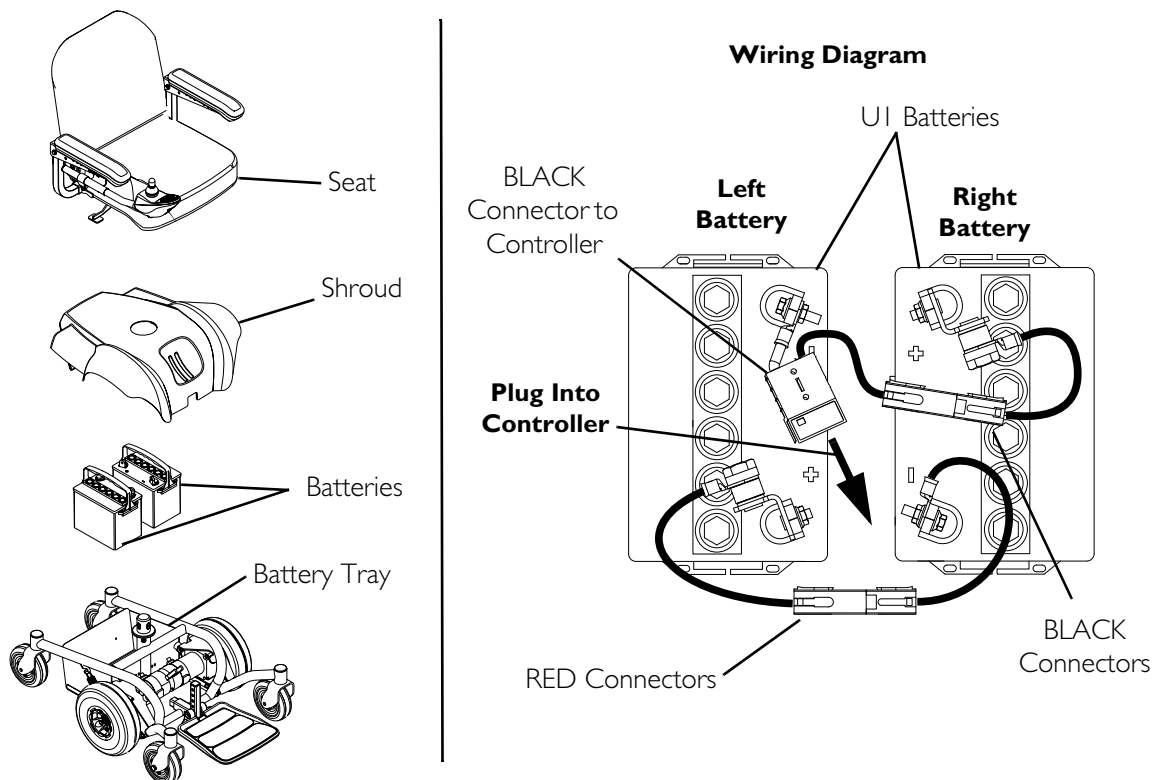

**FIGURE 13.1** Removing/Installing the Batteries

---

## Connecting/Disconnecting Battery Cables

### Connecting Battery Cables

---

#### **⚠ WARNING**

**NEVER** allow any of your tools and/or battery cable(s) to contact both battery terminal(s)/post(s) at the same time. An electrical short may occur and serious personal injury or damage may occur.

The use of rubber gloves is recommended when working with batteries.

---

#### **⚠ WARNING**

**DO NOT** remove fuse or mounting hardware from **POSITIVE (+) RED** battery cable/mounting screw.

Battery terminal configuration as shown in Detail “A” of **FIGURE 13.2** **MUST** be used. Batteries that have the terminal configuration reversed **MUST NOT** be used - otherwise serious injury or damage may occur.

Install protective caps on **POSITIVE (+)** and **NEGATIVE (-)** terminals.

All battery terminal covers (two on the front battery and two on the rear battery) **MUST** be installed prior to use.

---

#### **CAUTION**

When connecting the battery cables to the batteries, the battery cables **MUST** be connected to the battery terminals/posts, as shown in Detail “A” of **FIGURE 13.2** (depending on battery type), otherwise damage to the battery cable may result when installing battery terminal caps.

---

*NOTE: For this procedure, refer to FIGURE 13.3 and FIGURE 13.2 on page 62.*

1. Connect battery cables to batteries terminals/posts (FIGURE 13.2):
  - A. **NEGATIVE (-) BLACK** battery cable to **NEGATIVE (-)** battery terminal/post.
  - B. **POSITIVE (+) RED** battery cable to **POSITIVE (+)** battery terminal/post.
2. Secure the battery cables/ring terminals to the battery terminals/posts, **BLACK** to **NEGATIVE (-)** and **RED** to **POSITIVE (+)**, with the provided 1/4-20 x 5/8-inch hex flange screw and hex flange locknut. Securely tighten (Detail “A” of FIGURE 13.2).
3. Verify all battery cables/ring terminals are correctly installed and securely tightened.
4. Slide terminal caps down battery cables and onto battery clamps (FIGURE 13.2).

**SECTION 13—BATTERIES**

5. Secure each terminal cap in place with a tie-wrap (use tie-wraps 11-1/2-inches long) (Detail “B” of FIGURE 13.2).
6. Position the batteries into the wheelchair. Refer to Removing/Installing the Batteries on page 59.

*NOTE: New Battery(ies) MUST be fully charged before using, otherwise the life of the battery(ies) will be reduced.*

7. If necessary, charge the batteries. Refer to Charging Batteries on page 63.

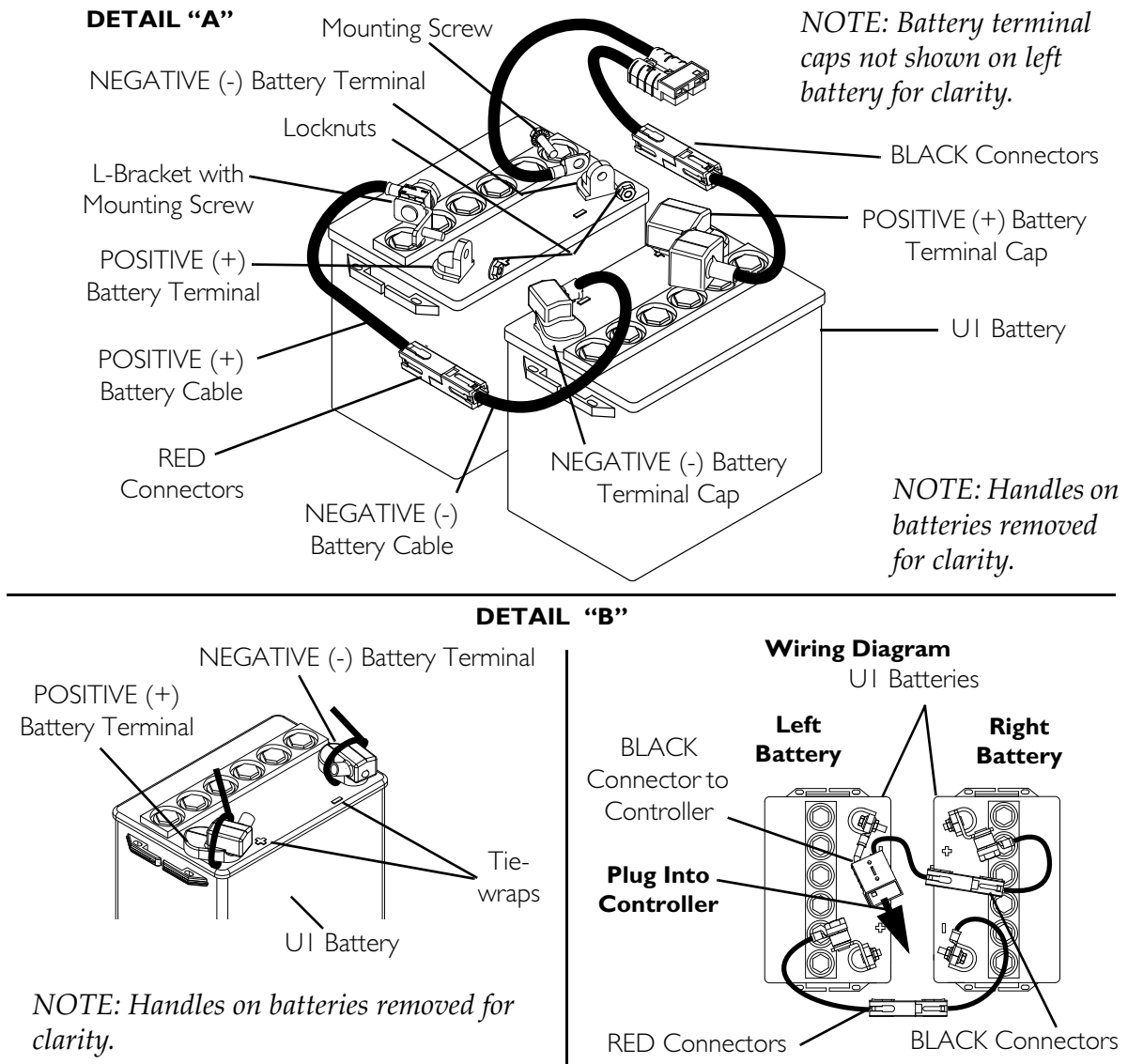

**FIGURE 13.2** Connecting/Disconnecting Battery Cables

## Disconnecting Battery Cables

### ⚠ WARNING

The use of rubber gloves is recommended when working with batteries.

**NEVER** allow any of your tools and/or battery cable(s) to contact **BOTH** battery terminal(s)/post(s) at the same time. An electrical short may occur and serious personal injury or damage may occur.

*NOTE: For this procedure, refer to FIGURE 13.2 on page 62 and FIGURE 13.3 on page 63.*

1. Remove the seat. Refer to Removing/Installing the Seat Assembly on page 37.
2. Remove the batteries. Refer to Removing/Installing the Batteries on page 59.
3. Cut the tie-wrap that secures the battery terminal cap in place (Detail “B” of FIGURE 13.2).
4. Slide terminal cap(s) UP on the battery cable(s) (FIGURE 13.3).
5. Disconnect POSITIVE (+) RED battery cable from the POSITIVE (+) battery terminal/post (FIGURE 13.2).
6. Disconnect NEGATIVE (-) BLACK battery cable from NEGATIVE (-) battery terminal/post (FIGURE 13.2).

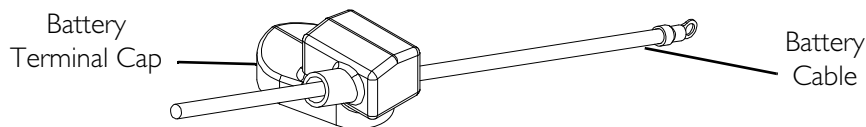

**FIGURE 13.3** Battery Terminal Caps

## Charging Batteries

### ⚠ WARNING

**NEVER** attempt to recharge the batteries by attaching cables directly to the battery terminals.

**DO NOT** attempt to recharge the batteries and operate the wheelchair at the same time.

**DO NOT** attempt to recharge the batteries when the wheelchair has been exposed to any type of moisture.

**DO NOT** attempt to recharge the batteries when the wheelchair is outside.

**DO NOT** sit in the wheelchair while recharging the batteries.

Read and carefully follow the individual instructions for each charger (supplied or purchased). If charging instructions are not supplied, consult a qualified technician for proper procedures.

---

## CAUTION

**New batteries MUST be fully charged prior to initial use of the wheelchair. ALWAYS charge new batteries before initial use or battery life will be reduced. As a general rule, you should recharge your batteries as frequently as possible to assure the longest possible life and to minimize required charging time. Plan to recharge them when you do not anticipate using the wheelchair.**

---

Basic concepts which will help you understand this automatic process are:

The amount of electrical current drawn within a given time to charge a battery is called “charge rate”. If, due to usage, the charge stored in the battery is low, the charge rate is high. As a charge builds up, the charge rate is reduced, and the battery charger rate decreases to a “trickle charge”.

*NOTE: If the batteries need to be charged more often or take longer to charge than normal, they may need to be replaced. Contact a qualified technician.*

*NOTE: The batteries can be charged by plugging an independent battery charger into the port located on the front of the joystick.*

## Battery Charger Operation

---

### ⚠ WARNING

**Read and carefully follow the manufacturer’s instructions for each charger (supplied or purchased). If charging instructions are not supplied, consult a qualified technician for proper procedures.**

**NEVER** leave the charger unattended when the charger circuit breaker is tripping. Use of improper extension cord could result in risk of fire and electric shock.

**Read and carefully follow the individual instructions for each charger (supplied or purchased). If charging instructions are not supplied, consult a qualified technician for proper procedures.**

---

---

**CAUTION**

**Only use a charger approved by Invacare when charging through the joystick on this wheelchair model.**

**DO NOT use an independent charger with an output rating of over 8A (Amps). Otherwise, damage may occur.**

---

*NOTE: For this procedure, refer to FIGURE 13.4 on page 65.*

*NOTE: The charger port located on the front of the joystick requires the use of an independent charger.*

1. Attach the battery charger connector to the charger port on the front of the joystick.
2. Plug the charger's AC power cord or extension into the grounded 110-volt wall outlet.
3. When charging is complete, turn charger off.
4. Disconnect output cable from charger port.

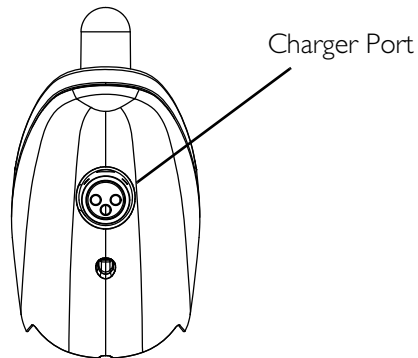

**FIGURE 13.4** Battery Charger Operation

## SECTION 14—ACCESSORIES

### ⚠ WARNING

After any adjustments, repair or service and before use, make sure that all attaching hardware is tightened securely - otherwise injury or damage may result.

Before performing any maintenance, adjustment or service verify that on/off switch on the joystick is in the off position.

### Installing/Removing the Crutch/Cane Holder

### ⚠ WARNING

The installation of the crutch/cane holder onto the back of the seat significantly increases the length of the wheelchair. When turning the wheelchair or swiveling the wheelchair seat, it is important to take note of this increased length - otherwise, injury and/or damage to the surrounding property may result.

NOTE: For this procedure, refer to FIGURE 14.1.

NOTE: The Crutch/Cane Holder, Oxygen Holder, and Walker Holder all install into the accessory tube. Only one of these may be installed at a time.

NOTE: To remove, reverse the following procedure.

#### Installing

1. If necessary, loosen but do not remove the mounting knob.
2. Install the crutch/cane holder into the accessory tube located on the back of the seat.
3. Thread the mounting knob into the welded nut on the accessory tube. Securely tighten.
4. Align slot on base with hook on crutch/cane holder and slide base down into position.

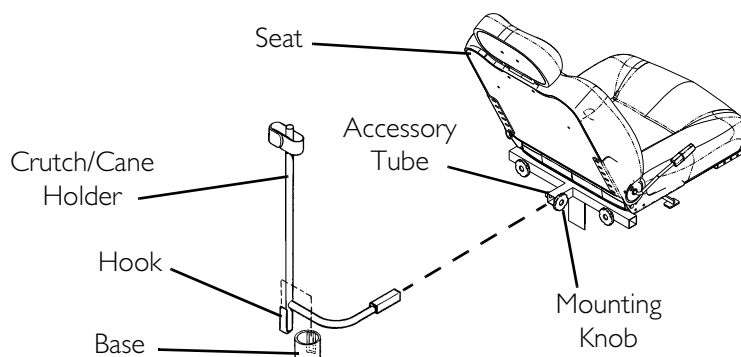

**FIGURE 14.1** Installing/Removing the Crutch/Cane Holder

---

## Installing/Removing the Oxygen Holder

---

### **⚠ WARNING**

Contact your oxygen supplier for instructions in the use of oxygen. Extreme care **MUST** be exercised when using oxygen in close proximity to electric circuits.

The Invacare oxygen holder is designed to be used in conjunction with oxygen cylinder models MD15 and ME24 only.

To maintain safety, use only Invacare oxygen cylinder accessories (i.e. regulator, oxygen demand devices).

**DO NOT** use the oxygen holder for anything other than its intended purpose of supporting an oxygen cylinder - otherwise, injury or damage may occur.

**DO NOT** attempt to modify the oxygen holder to fit any other type of wheelchair. The oxygen holder was designed specifically for Invacare wheelchairs only.

The installation of the oxygen holder onto the back of the wheelchair seat significantly increases the length of the wheelchair. When turning the wheelchair it is important to take note of this increased length - otherwise, injury or damage may occur.

When using nasal or masked type administering equipment, oxygen or air tubing **MUST** be routed and secured properly to ensure that the tubing does not become entangled, kinked or severed. If necessary, loosen but **DO NOT** remove the mounting knob.

---

*NOTE: For this procedure, refer to FIGURE 14.2 on page 68.*

*NOTE: Reverse the following procedure to remove the oxygen holder.*

*NOTE: The Crutch/Cane Holder, Oxygen Holder, and Walker Holder all install into the accessory tube. Only one of these may be installed at a time.*

1. Install the mounting tube of the oxygen holder into the accessory tube located on the back of the seat.
2. Position the appropriate fastener into the welded nut on the accessory tube.
3. Grip the mounting hand knob firmly, and securely tighten it.
4. Thread the two clamp knobs through the two welded nuts on the upper support of the oxygen holder, and position the two protective caps on the end of the clamp knobs.
5. Repeat STEP 4 for the two clamp knobs on the lower support of the oxygen holder.

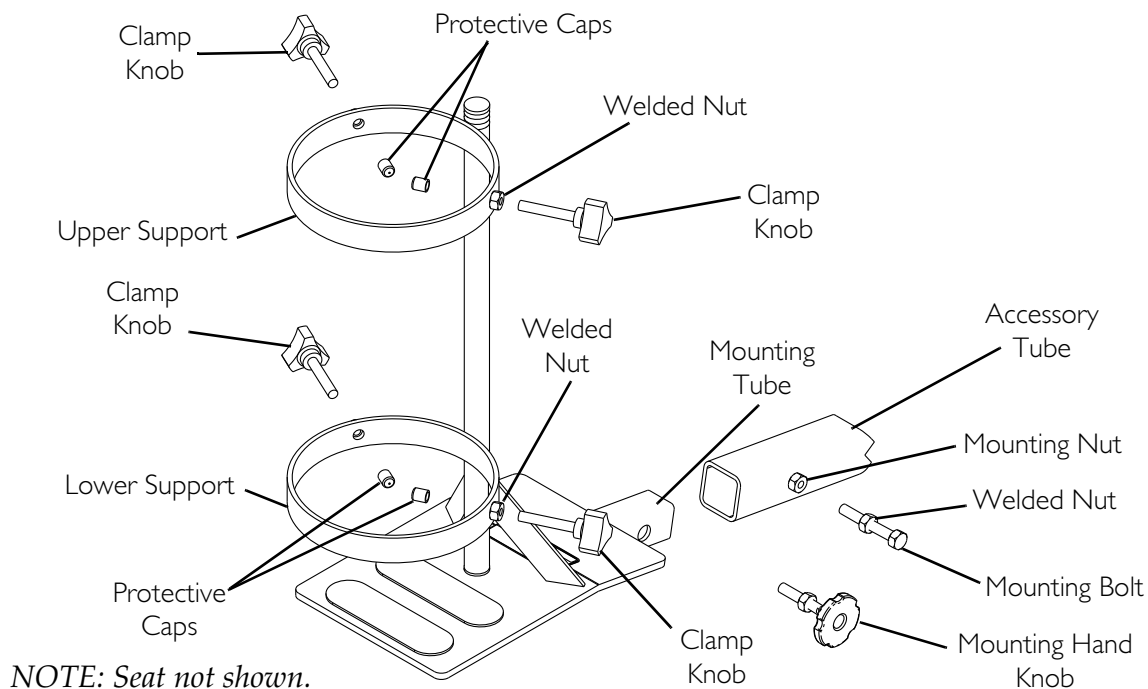

**FIGURE 14.2** Installing/Removing the Oxygen Holder

## Installing/Removing/Using the Walker Holder

### ⚠ INSTALLATION WARNINGS

After any adjustments, repair or service and before use, make sure that all attaching hardware is tightened securely.

The installation of the walker holder onto the back of the wheelchair seat increases the length of the wheelchair up to nine inches. When turning the wheelchair it is important to take note of this increased length - otherwise, injury and/or damage to surrounding property may result.

NOTE: For this procedure, refer to FIGURE 14.3 on page 69.

### Installing/Removing the Walker Holder

NOTE: Reverse this procedure to remove the walker holder.

NOTE: The Crutch/Cane Holder, Oxygen Holder, and Walker Holder all install into the accessory tube. Only one of these may be installed at a time.

1. If necessary, loosen but do not remove the mounting knob.
2. Install the walker holder into the accessory tube.
3. Thread the mounting knob into the welded nut on the accessory tube. Securely tighten.

## Using the Walker Holder

1. Fold walker. Refer to instructions provided with the walker.

*NOTE: Walker MUST be folded before using walker holder.*

2. Hang folded walker on walker holder hooks.
3. Secure walker with hook and loop straps.

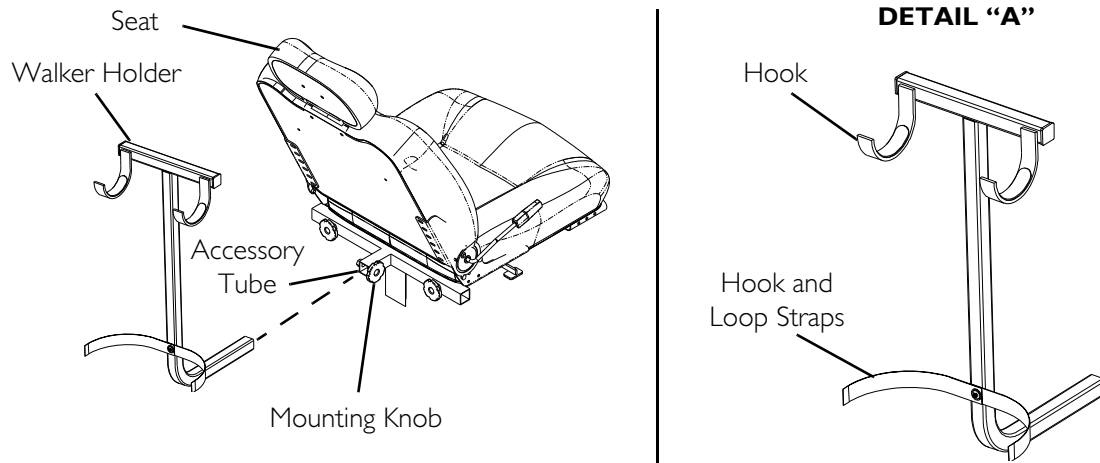

**FIGURE 14.3** Installing/Removing/Using the Walker Holder

# NOTES

# **GLOBAL LIMITED WARRANTY (EXCLUDING CANADA)**

**PLEASE NOTE: THE WARRANTY BELOW HAS BEEN DRAFTED TO COMPLY WITH FEDERAL LAW APPLICABLE TO PRODUCTS MANUFACTURED AFTER JULY 4, 1975.**

This warranty is extended only to the original purchaser who purchases this product within any country excluding CANADA when new and unused from Invacare or a dealer. This warranty is not extended to any other person or entity and is not transferable or assignable to any subsequent purchaser or owner. Coverage under this warranty will end upon any such subsequent sale or other transfer of title to any other person. For product purchased in Canada, please refer to the Canada Limited Warranty.

This warranty gives you specific legal rights and you may also have other legal rights which vary from state to state. Invacare warrants the base frame to be free from defects in materials and workmanship for a period of five (5) years from the date of purchase from Invacare or a dealer, with a copy of the seller's invoice required for coverage under this warranty. Invacare warrants the seat frame to be free from defects in materials and workmanship for a period of three (3) years from the date of purchase from Invacare or a dealer, with a copy of the seller's invoice required for coverage under this warranty. Invacare warrants all electronics and electrical components (excluding batteries), motors and gearboxes to be free from defects in materials and workmanship for a period of one (1) year from the date of purchase from Invacare or a dealer, with a copy of the seller's invoice required for coverage under this warranty. Invacare warrants all batteries to be free from defects in materials and workmanship for a period of six (6) months from the date of purchase from Invacare or a dealer, with a copy of the seller's invoice required for coverage under this warranty. Invacare warrants all remaining components (excluding all upholstered materials, padded materials, tires and wheels) to be free from defects in materials and workmanship for a period of one (1) year from the date of purchase from Invacare or a dealer, with a copy of the seller's invoice required for coverage under this warranty. If within such warranty periods any such product component shall be proven to be defective, the product component shall be repaired or replaced, at Invacare's option. This warranty does not include any labor or shipping charges incurred in replacement part installation or repair of any such product. Invacare's sole obligation and your exclusive remedy under this warranty shall be limited to such repair and/or replacement.

For warranty service, please contact the dealer from whom you purchased your Invacare product. In the event you do not receive satisfactory warranty service, please write directly to Invacare at the address on the bottom of the back cover. Provide dealer's name address, date of purchase, indicate nature of the defect and, if the product is serialized, indicate the serial number. Do not return products to our factory without our prior consent.

**LIMITATIONS AND EXCLUSIONS: THE FOREGOING WARRANTY SHALL NOT APPLY TO SERIAL NUMBERED PRODUCTS IF THE SERIAL NUMBER HAS BEEN REMOVED OR DEFACED, PRODUCTS SUBJECT TO NEGLIGENCE, ACCIDENT, IMPROPER OPERATION, MAINTENANCE OR STORAGE, COMMERCIAL OR INSTITUTIONAL USE, PRODUCTS MODIFIED WITHOUT INVACARE'S EXPRESS WRITTEN CONSENT (INCLUDING, BUT NOT LIMITED TO, MODIFICATION THROUGH THE USE OF UNAUTHORIZED PARTS OR ATTACHMENTS); PRODUCTS DAMAGED BY REASON OF REPAIRS MADE TO ANY COMPONENT WITHOUT THE SPECIFIC CONSENT OF INVACARE, OR TO A PRODUCT DAMAGED BY CIRCUMSTANCES BEYOND INVACARE'S CONTROL, AND SUCH EVALUATION WILL BE SOLELY DETERMINED BY INVACARE. THE WARRANTY SHALL NOT APPLY TO PROBLEMS ARISING FROM NORMAL WEAR AND TEAR OR FAILURE TO ADHERE TO THE PRODUCT INSTRUCTIONS. A CHANGE IN OPERATING NOISE, PARTICULARLY RELATIVE TO MOTORS AND GEARBOXES DOES NOT CONSTITUTE A FAILURE OR DEFECT AND WILL NOT BE REPAIRED; ALL DEVICES WILL EXHIBIT CHANGES IN OPERATING NOISE DUE TO AGING.**

**THE FOREGOING EXPRESS WARRANTY IS EXCLUSIVE AND IN LIEU OF ANY OTHER WARRANTIES WHATSOEVER, WHETHER EXPRESS OR IMPLIED, INCLUDING THE IMPLIED WARRANTIES OF MERCHANTABILITY AND FITNESS FOR A PARTICULAR PURPOSE, AND THE SOLE REMEDY FOR VIOLATIONS OF ANY WARRANTY WHATSOEVER, SHALL BE LIMITED TO REPAIR OR REPLACEMENT OF THE DEFECTIVE PRODUCT PURSUANT TO THE TERMS CONTAINED HEREIN. THE APPLICATION OF ANY IMPLIED WARRANTY WHATSOEVER SHALL NOT EXTEND BEYOND THE DURATION OF THE EXPRESS WARRANTY PROVIDED HEREIN AND INVACARE SHALL NOT BE LIABLE FOR ANY CONSEQUENTIAL OR INCIDENTAL DAMAGES WHATSOEVER; SOME STATES DO NOT ALLOW THE EXCLUSION OR LIMITATION OF INCIDENTAL OR CONSEQUENTIAL DAMAGE, OR LIMITATION OF HOW LONG AN IMPLIED WARRANTY LASTS, SO THE ABOVE EXCLUSION AND LIMITATION MAY NOT BE APPLICABLE.**

**THIS WARRANTY SHALL BE EXTENDED TO COMPLY WITH STATE/PROVINCIAL LAWS AND REQUIREMENTS.**

---

# CANADA LIMITED WARRANTY

**PLEASE NOTE: THE WARRANTY BELOW HAS BEEN DRAFTED TO COMPLY WITH FEDERAL LAW APPLICABLE TO PRODUCTS MANUFACTURED AFTER JULY 4, 1975.**

This warranty is extended only to the original purchaser who purchases this product within Canada when new and unused from Invacare or a dealer. This warranty is not extended to any other person or entity and is not transferable or assignable to any subsequent purchaser or owner. Coverage under this warranty will end upon any such subsequent sale or other transfer of title to any other person.

This warranty gives you specific legal rights and you may also have other legal rights which vary from state to state.

Invacare warrants the base frame to be free from defects in materials and workmanship for a period of five (5) years from the date of purchase from Invacare or a dealer, with a copy of the seller's invoice required for coverage under this warranty. Invacare warrants the seat frame to be free from defects in materials and workmanship for a period of three (3) years from the date of purchase from Invacare or a dealer, with a copy of the seller's invoice required for coverage under this warranty. Invacare warrants all electronics and electrical components (excluding batteries), motors and gearboxes to be free from defects in materials and workmanship for a period of two (2) years from the date of purchase from Invacare or a dealer, with a copy of the seller's invoice required for coverage under this warranty. Invacare warrants all batteries to be free from defects in materials and workmanship for a period of six (6) months from the date of purchase from Invacare or a dealer, with a copy of the seller's invoice required for coverage under this warranty. Invacare warrants all remaining components (excluding all upholstered materials, padded materials, tires and wheels) to be free from defects in materials and workmanship for a period of one (1) year from the date of purchase from Invacare or a dealer, with a copy of the seller's invoice required for coverage under this warranty. If within such warranty periods any such product component shall be proven to be defective, the product component shall be repaired or replaced, at Invacare's option. This warranty does not include any labor or shipping charges incurred in replacement part installation or repair of any such product. Invacare's sole obligation and your exclusive remedy under this warranty shall be limited to such repair and/or replacement.

For warranty service, please contact the dealer from whom you purchased your Invacare product. In the event you do not receive satisfactory warranty service, please write directly to Invacare at the address on the bottom of the back cover. Provide dealer's name address, date of purchase, indicate nature of the defect and, if the product is serialized, indicate the serial number. Do not return products to our factory without our prior consent.

**LIMITATIONS AND EXCLUSIONS: THE FOREGOING WARRANTY SHALL NOT APPLY TO SERIAL NUMBERED PRODUCTS IF THE SERIAL NUMBER HAS BEEN REMOVED OR DEFACED, PRODUCTS SUBJECT TO NEGLIGENCE, ACCIDENT, IMPROPER OPERATION, MAINTENANCE OR STORAGE, COMMERCIAL OR INSTITUTIONAL USE, PRODUCTS MODIFIED WITHOUT INVACARE'S EXPRESS WRITTEN CONSENT (INCLUDING, BUT NOT LIMITED TO, MODIFICATION THROUGH THE USE OF UNAUTHORIZED PARTS OR ATTACHMENTS); PRODUCTS DAMAGED BY REASON OF REPAIRS MADE TO ANY COMPONENT WITHOUT THE SPECIFIC CONSENT OF INVACARE, OR TO A PRODUCT DAMAGED BY CIRCUMSTANCES BEYOND INVACARE'S CONTROL, AND SUCH EVALUATION WILL BE SOLELY DETERMINED BY INVACARE. THE WARRANTY SHALL NOT APPLY TO PROBLEMS ARISING FROM NORMAL WEAR AND TEAR OR FAILURE TO ADHERE TO THE PRODUCT INSTRUCTIONS. A CHANGE IN OPERATING NOISE, PARTICULARLY RELATIVE TO MOTORS AND GEARBOXES DOES NOT CONSTITUTE A FAILURE OR DEFECT AND WILL NOT BE REPAIRED; ALL DEVICES WILL EXHIBIT CHANGES IN OPERATING NOISE DUE TO AGING.**

**THE FOREGOING EXPRESS WARRANTY IS EXCLUSIVE AND IN LIEU OF ANY OTHER WARRANTIES WHATSOEVER, WHETHER EXPRESS OR IMPLIED, INCLUDING THE IMPLIED WARRANTIES OF MERCHANTABILITY AND FITNESS FOR A PARTICULAR PURPOSE, AND THE SOLE REMEDY FOR VIOLATIONS OF ANY WARRANTY WHATSOEVER, SHALL BE LIMITED TO REPAIR OR REPLACEMENT OF THE DEFECTIVE PRODUCT PURSUANT TO THE TERMS CONTAINED HEREIN. THE APPLICATION OF ANY IMPLIED WARRANTY WHATSOEVER SHALL NOT EXTEND BEYOND THE DURATION OF THE EXPRESS WARRANTY PROVIDED HEREIN AND INVACARE SHALL NOT BE LIABLE FOR ANY CONSEQUENTIAL OR INCIDENTAL DAMAGES WHATSOEVER; SOME STATES DO NOT ALLOW THE EXCLUSION OR LIMITATION OF INCIDENTAL OR CONSEQUENTIAL DAMAGE, OR LIMITATION OF HOW LONG AN IMPLIED WARRANTY LASTS, SO THE ABOVE EXCLUSION AND LIMITATION MAY NOT BE APPLICABLE.**

**THIS WARRANTY SHALL BE EXTENDED TO COMPLY WITH STATE/PROVINCIAL LAWS AND REQUIREMENTS.**

Invacare Corporation [www.invacare.com](http://www.invacare.com)



**Yes, you can.®**

**USA**

One Invacare Way  
Elyria, Ohio USA  
44036-2125  
800-333-6900

**Canada**

570 Matheson Blvd E Unit 8  
Mississauga Ontario  
L4Z 4G4 Canada  
800-668-5324

All rights reserved. Trademarks are identified by the symbols <sup>™</sup> and <sup>®</sup>. All trademarks are owned by or licensed to Invacare Corporation unless otherwise noted.

Phillips is a registered trademark of the Phillips Screw Company.

© 2008 Invacare Corporation

Part No. I143206

Rev F - 6/08