

Owner's Operator and Maintenance Manual

Compass™ SPT™ Compass SPT Limited

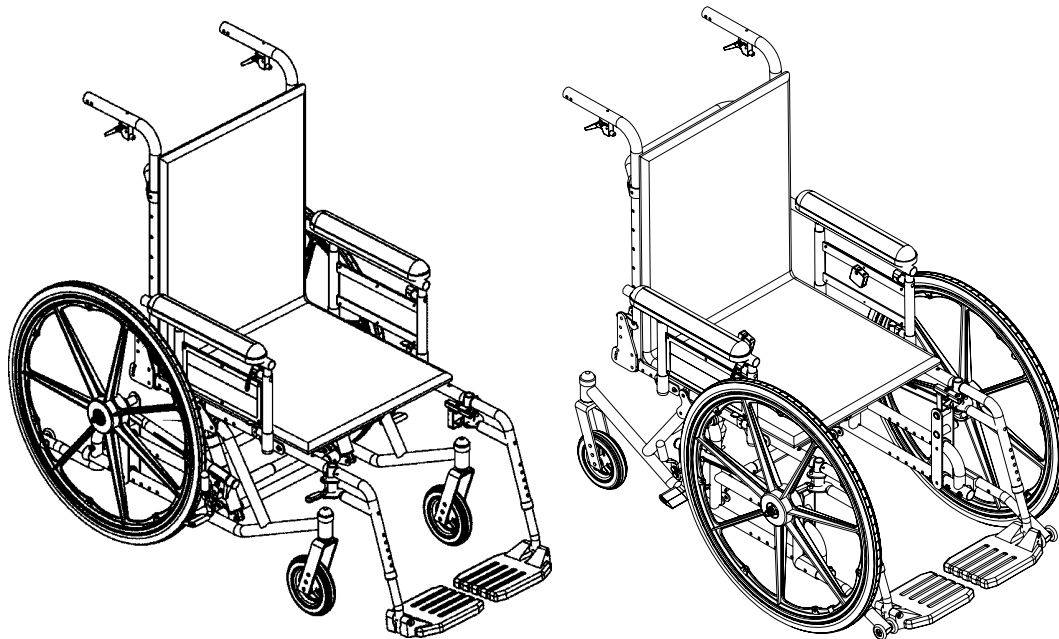

DEALER: This manual **MUST** be given to the user of the wheelchair.

USER: **BEFORE** using this wheelchair, read this manual and save for future reference.

For more information regarding Invacare products, parts, and services, please visit www.invacare.com



Yes, you can.®

⚠ WARNING

A QUALIFIED TECHNICIAN MUST PERFORM THE INITIAL SET UP OF THIS WHEELCHAIR. ALSO, A QUALIFIED TECHNICIAN MUST PERFORM ALL PROCEDURES SPECIFICALLY INDICATED IN THE MANUAL.

WHEELCHAIR USERS: DO NOT SERVICE OR OPERATE THIS EQUIPMENT WITHOUT FIRST READING AND UNDERSTANDING THE OWNER'S OPERATOR AND MAINTENANCE MANUAL AND THE SEATING SYSTEM'S MANUAL (IF APPLICABLE). IF YOU ARE UNABLE TO UNDERSTAND THE WARNINGS, CAUTIONS, AND INSTRUCTIONS, CONTACT INVACARE TECHNICAL SUPPORT BEFORE ATTEMPTING TO SERVICE OR OPERATE THIS EQUIPMENT - OTHERWISE INJURY OR DAMAGE MAY RESULT.

DEALERS AND QUALIFIED TECHNICIANS: DO NOT SERVICE OR OPERATE THIS EQUIPMENT WITHOUT FIRST READING AND UNDERSTANDING THE OWNER'S OPERATOR AND MAINTENANCE MANUAL, THE SERVICE MANUAL (IF APPLICABLE) AND THE SEATING SYSTEM'S MANUAL (IF APPLICABLE). IF YOU ARE UNABLE TO UNDERSTAND THE WARNINGS, CAUTIONS AND INSTRUCTIONS, CONTACT INVACARE TECHNICAL SUPPORT BEFORE ATTEMPTING TO SERVICE OR OPERATE THIS EQUIPMENT - OTHERWISE, INJURY OR DAMAGE MAY RESULT.

NOTE: Updated versions of this manual are available on www.invacare.com.

TABLE OF CONTENTS

REGISTER YOUR PRODUCT	6
SPECIAL NOTES	9
LABEL LOCATIONS	11
FEATURES	12
TYPICAL PRODUCT PARAMETERS	13
SECTION 1—GENERAL GUIDELINES	14
Information for Healthcare Professionals/Assistants	14
Stability.....	14
Operating Information.....	15
Weight Training	16
Weight Limitation.....	16
SECTION 2—SAFETY/HANDLING	17
Safety/Handling of Wheelchairs.....	17
Stability and Balance.....	17
Coping With Everyday Obstacles.....	18
A Note to Wheelchair Assistants	18
Reaching, Leaning and Bending - Forward	19
Reaching and Leaning - Backwards.....	20
Tipping - Rear Wheel Configuration Only	20
Tipping - Curbs: Method 1 - Wheelchair with Step Tubes.....	20
Tipping - Curbs: Method 2 - Wheelchair without Step Tube	21
Tipping - Front Wheel Configuration Only.....	22
Stairways - Rear Wheel Configuration Only	22
Stairways - Front Wheel Configuration Only.....	23
Escalators.....	24
Transferring To and From Other Seats	24
SECTION 3—SAFETY INSPECTION CHECKLIST	25
Safety Inspection Checklists.....	25
Inspect/Adjust Initially	25
Inspect/Adjust Weekly.....	26
Inspect/Adjust Monthly.....	26
Inspect/Adjust Periodically.....	27
Troubleshooting - Mechanical	27
Maintenance/Transporting.....	28
Suggested Maintenance Procedures	28
Transporting the Invacare Compass SPT	29

TABLE OF CONTENTS

SECTION 4—FRONT RIGGINGS	30
Installing/Removing Swingaway Front Riggings	30
Installing.....	30
Removing	30
Installing/Removing Lift-Off Footrest.....	31
Installing.....	31
Removing	31
Adjusting Footrest Height	31
Height Adjustment Ranges.....	31
60°, 70° and 70° Taper.....	31
70° MFX, 90°, 70° LIFT and 90° LIFT Footrests	32
Model PHW93 and PH904A Front Riggings.....	32
Installing Adjustable Angle Flip-up Footplate Hinge	33
Adjusting Adjustable Angle Flip-up Footplates	34
Depth Adjustment	34
Angle Adjustment	34
Composite/Articulating Footplate Heel Loop Replacement	35
Disassembly	35
Reassembly	35
Installing/Removing Elevating Legrests.....	35
Installing.....	35
Removing	36
Raising/Lowering the Elevating Legrest	36
Adjusting Footplate Height and Calfpad Height/Depth	37
Adjusting the Footplate Height.....	37
Adjusting Calfpad Height.....	37
Adjusting Calfpad Depth	37
Composite/Articulating Footplate Heel Loop Replacement	38
Disassembly	38
Reassembly	38
Replacing Sector Block.....	38
Installing Impact Guards/Calf Strap/H-Calf Strap	39
SECTION 5—ARMS	40
Using/Adjusting Dual Point Arms	40
Installing Armrest.....	40
Removing Armrest.....	40
Adjusting Armrest.....	40
Replacing Dual Point Arm Pad	41

TABLE OF CONTENTS

Replacing Dual Point Arm Clothing Guards	41
Installing/Removing T-Arms	42
Installing T-Arms	42
Removing T-Arms.....	42
Adjusting The T-Arms.....	43
Adjusting T-Arm Height.....	43
Adjusting T-Arm Width	44
Adjusting T-Arm Depth.....	44
Adjusting T-Arm Sockets.....	45
Adjusting T-Arm Transfer Assists And/or Side Guards	46
SECTION 6—BACK/SEAT	47
Folding/Unfolding Back Assembly	47
Installing and Removing a Seating System	48
Installing Stroller Handle.....	48
Installing/Removing/Adjusting the Adjustable Angle Stroller Handles	49
Installing.....	49
Removing	49
Adjusting/Replacing the Back Release Cord.....	50
Adjusting the Back Release Cord.....	50
Replacing the Back Release Cord.....	50
Installing/Replacing Seat Positioning Straps.....	51
Installing.....	51
Replacing	51
Installing/Replacing Chest Positioning Straps	52
Installing.....	52
Replacing	52
SECTION 7—TILT	53
Engaging Tilt-In-Space	53
Adjusting Trigger Release Cables	54
14 to 20-Inch Wide Wheelchairs.....	54
21 to 22-Inch Wide Wheelchairs.....	55
SECTION 8—WHEELS	57
Installing/Replacing Six or Eight-inch Caster/Fork	57
Installing Caster/Fork.....	57
Replacing Caster/Fork.....	57
Replacing/Repairing Caster Tire/Tube.....	58
Installing/Removing Rear Wheels	58

TABLE OF CONTENTS

Quick-Release	58
Permanent Axle.....	59
Adjusting the Quick-Release Axle	59
Replacing Wheel Handrim.....	60
Replacing/Repairing Wheel Tire/Tube	60
SECTION 9—WHEEL LOCKS AND ANTI-TIPPERS	61
Wheel Lock Adjustment.....	61
Installing/Adjusting Anti-Tippers	62
Installing Anti-Tippers	62
Adjusting Anti-Tippers.....	62
LIMITED WARRANTY	63

REGISTER YOUR PRODUCT

The benefits of registering:

1. Safeguard your investment.
2. Ensure long term maintenance and servicing of your purchase.
3. Receive updates with product information, maintenance tips, and industry news.
4. Invacare can contact you or your provider, if servicing is needed on your product.
5. It will enable Invacare to improve product designs based on your input and needs.

Register ONLINE at www.invacare.com

- or -

Complete and mail the form on the next page

Any registration information you submit will be used by Invacare Corporation only, and protected as required by applicable laws and regulations.



PRODUCT REGISTRATION FORM

Register **ONLINE** at www.invacare.com - or -
Complete and mail this form

Name _____

Address _____

City _____ State/Province _____

Zip/Postal Code _____

Email _____ Phone No. _____

Fold
here

Invacare Model No. _____ Serial No. _____

Purchased From _____ Date of Purchase: _____

1. Method of purchase: (check all that apply)

Medicare Insurance Medicaid Other _____

2. This product was purchased for use by: (check one)

Self Parent Spouse Other

3. Product was purchased for use at:

Home Facility Other

4. I purchased an Invacare product because:

Price Features (list features) _____

5. Who referred you to Invacare products? (check all that apply)

Doctor Therapist Friend Relative Dealer/Provider Other _____

Advertisement (circle one): TV, Radio, Magazine, Newspaper No Referral _____

6. What additional features, if any, would you like to see on this product?

Fold
here

7. Would you like information sent to you about Invacare products that may be available for a particular medical condition? Yes No

If yes, please list any condition(s) here and we will send you information by email and/or mail about any available Invacare products that may help treat, care for or manage such condition(s):

8. Would you like to receive updated information via email or regular mail about the Invacare home medical products sold by Invacare's dealers? Yes No

9. What would you like to see on the Invacare website?

10. Would you like to be part of future online surveys for Invacare products? Yes No

11. User's Year of birth: _____

If at any time you wish not to receive future mailings from us, please contact us at Invacare Corporation, CRM Department, 39400 Taylor Parkway, Elyria, OH 44035, or fax to 877-619-7996 and we will remove you from our mailing list.

To find more information about our products, visit www.invacare.com.

Cut Along Line



Fold
here



BUSINESS REPLY MAIL
FIRST-CLASS MAIL PERMIT NO. 196 ELYRIA OH

POSTAGE WILL BE PAID BY ADDRESSEE

NO POSTAGE
NECESSARY
IF MAILED
IN THE
UNITED STATES

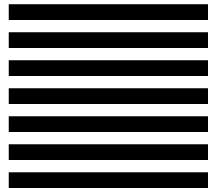

INVACARE CORPORATION
CRM DEPARTMENT
39400 TAYLOR PARKWAY
ELYRIA OH 44035-9836



Fold
here

Invacare Product Registration Form

Please Seal with
Tape Before Mailing

Cut Along Line



SPECIAL NOTES

Signal words are used in this manual and apply to hazards or unsafe practices which could result in personal injury or property damage. Refer to the table below for definitions of the signal words.

SIGNAL WORD	MEANING
DANGER	Danger indicates an imminently hazardous situation which, if not avoided, will result in death or serious injury.
WARNING	Warning indicates a potentially hazardous situation which, if not avoided, could result in death or serious injury.
CAUTION	Caution indicates a potentially hazardous situation which, if not avoided, may result in property damage.

NOTICE

THE INFORMATION CONTAINED IN THIS DOCUMENT IS SUBJECT TO CHANGE WITHOUT NOTICE.

WHEELCHAIR USER

As a manufacturer of wheelchairs, Invacare endeavors to supply a wide variety of wheelchairs to meet many needs of the end user. However, final selection of the type of wheelchair to be used by an individual rests solely with the user and his/her healthcare professional capable of making such a selection.

TIE DOWN RESTRAINTS AND SEAT RESTRAINTS

Invacare recommends that wheelchair users not be transported in vehicles of any kind while in wheelchairs. As of this date, the Department of Transportation has not approved any tie-down systems for transportation of a user while in a wheelchair, in a moving vehicle of any type.

It is Invacare's position that users of wheelchairs should be transferred into appropriate seating in vehicles for transportation and use be made of the restraints made available by the auto industry. Invacare cannot and does not recommend any wheelchair transportation systems.

SEAT POSITIONING STRAP

ALWAYS wear your seat positioning strap. Inasmuch as the seat positioning strap is an option on this wheelchair (you may order with or without the seat positioning strap), Invacare strongly recommends ordering the seat positioning strap as an additional safeguard for the wheelchair user. The seat positioning strap is a positioning belt only. It is not designed for use as a safety device withstanding high stress loads such as auto or aircraft safety belts. If signs of wear appear, seat positioning strap **MUST** be replaced **IMMEDIATELY**.

With regards to restraints - seat/chest positioning straps - it is the obligation of the DME dealer, therapists and other healthcare professionals to determine if a seat/chest positioning strap is required to ensure the safe operation of this equipment by the user. **SERIOUS INJURY CAN OCCUR IN THE EVENT OF A FALL FROM A WHEELCHAIR.**

⚠ WARNING

Invacare products are specifically designed and manufactured for use in conjunction with Invacare accessories. Accessories designed by other manufacturers have not been tested by Invacare and are not recommended for use with Invacare products.

TO HEALTHCARE PROFESSIONALS/ASSISTANTS:

The Invacare Compass SPT wheelchair MUST be operated by a healthcare professional or assistant when in any tilt position.

LABEL LOCATIONS

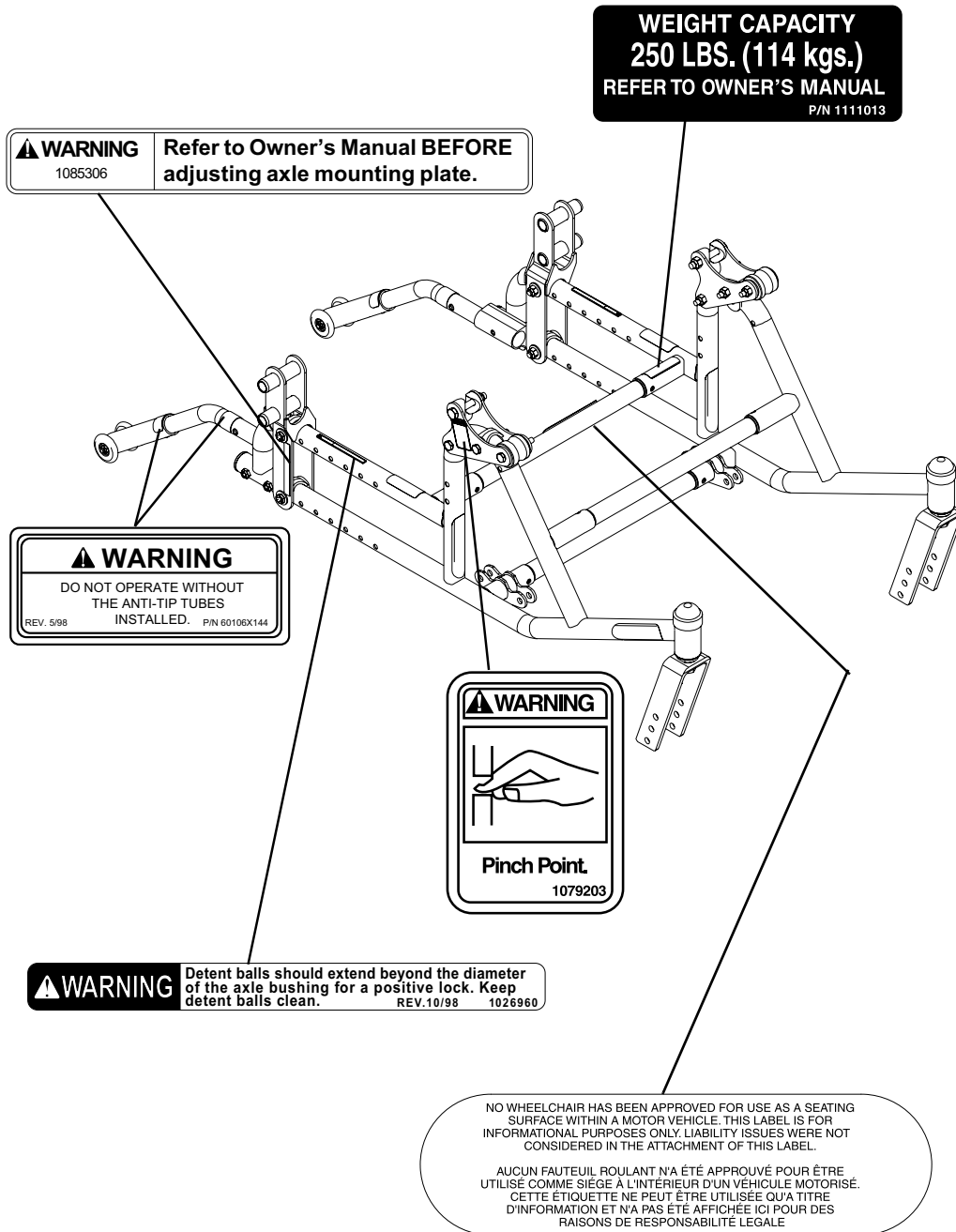

FEATURES

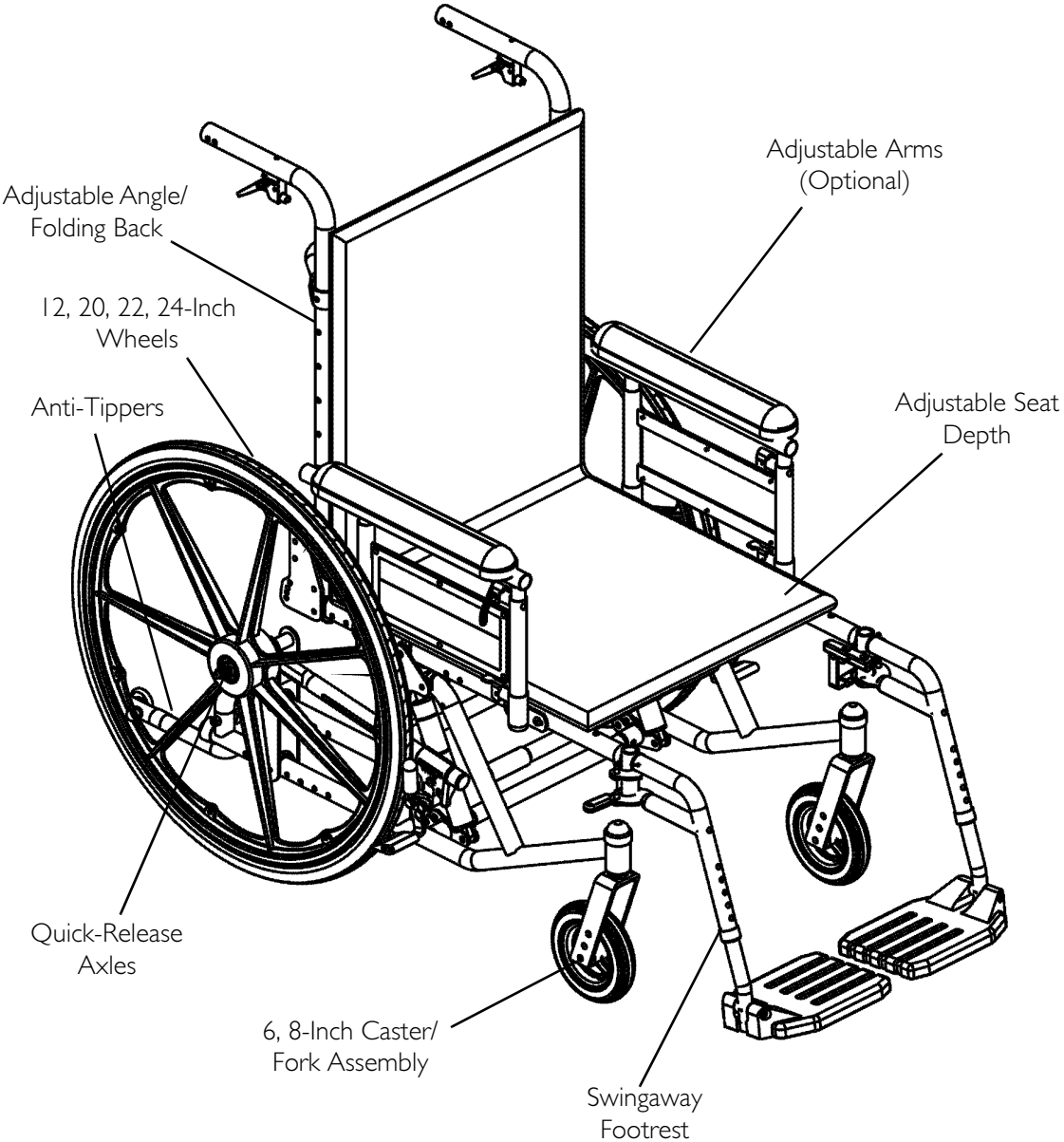

TYPICAL PRODUCT PARAMETERS

	INVACARE COMPASS SPT
*OVERALL WIDTH:	27½ inches (seat width + 9½-inches)
*OVERALL DEPTH:	33 to 39 inches
OVERALL HEIGHT:	39½ inches (seat-to-floor + back cane height)
ANTI-TIPPERS:	Standard
FOOTREST:	Swing-Away Footrest Lift-off Footrest (Optional) Elevating Swing-Away Footrest (Optional) Articulating Swing-Away Footrest (Optional)
ARMRESTS DUAL POINT ARMS: LOCKING CANTILEVER ARMS: T-ARMS:	Desk or Full Length, Adjustable or Fixed Height Desk or Full Length Desk or Full Length, Adjustable Height
SEAT PAN:	Optional
BACK:	Fixed - 20 or 24 inches
BACK ANGLE ADJUSTMENT:	90° to 120° (10° increments)
REAR AXLE:	Quick-Release or Fixed
REAR WHEELS:	12, 20, 22, and 24-inch Composite
HANDRIMS:	Aluminum, Steel, Plastic Coated or Projections
CASTER SIZE:	8-inch w/ Precision Sealed Bearings 6 x 1-inch w/ Precision Sealed Bearings 6 x 2-inch w/ Precision Sealed Bearings
SEAT WIDTH:	4 to 22 inches
SEAT DEPTH:	15 to 22 inches
WHEEL LOCKS:	Push-to-Lock, Pull-to-Lock
TILT-IN-SPACE:	Dual Cable Trigger Mechanism 15 to 20-inch deep wheelchairs - 45° of Tilt 21 to 22-inch deep wheelchairs - 35° of Tilt
FRAME:	Steel
WEIGHT LIMITATION:	250 pounds

**NOTE: 18-inch x 18-inch seating, no footrests, no anti-tippers, in reverse configuration, with 22-inch wheels.*

SECTION I—GENERAL GUIDELINES

Information for Healthcare Professionals/Assistants

The Invacare Compass SPT wheelchair MUST be operated by a healthcare professional or assistant when in any tilt position.

Stability

The back height, seat depth, back angle, seating system, tilt angle, seat height, size/position of the rear wheels, size/position of the front casters, as well as the user condition directly relate to the stability of the wheelchair. Any change to one or any combination of the eleven may cause the wheelchair to decrease in stability. These adjustments MUST be performed by a qualified technician.

<i>NOTE: When changes to the left hand column occur, follow across the chart and refer to the X procedure to maintain the proper stability, safety and handling of the wheelchair.</i>	BACK HEIGHT	SEAT DEPTH	BACK ANGLE	SEATING SYSTEM	TILT ANGLE	CASTER SIZE	CASTER POSITION	WHEEL SIZE	WHEEL POSITION	USER CONDITION	WHEEL LOCKS	ANTI-TIPPERS	LOCKING COLLAR
BACK HEIGHT	•	X	X	X	X	X	X	X	X	N/A	N/A	N/A	N/A
SEAT DEPTH	X	•	X	X	N/A	X	X	X	X	N/A	N/A	N/A	X
BACK ANGLE	X	X	•	X	X	X	X	X	X	N/A	N/A	N/A	X
SEATING SYSTEM	X	X	X	•	X	X	X	X	X	X	N/A	N/A	X
TILT ANGLE	N/A	N/A	X	N/A	•	N/A	N/A	N/A	N/A	N/A	N/A	N/A	X
CASTER SIZE	X	N/A	X	N/A	N/A	•	X	X	X	N/A	X	X	X
CASTER POSITION	X	N/A	X	N/A	N/A	X	•	X	X	N/A	X	X	X
WHEEL SIZE	X	N/A	X	N/A	N/A	X	X	•	X	N/A	X	X	X
WHEEL POSITION	X	N/A	X	N/A	N/A	X	X	X	•	N/A	X	X	X
USER CONDITION	X	X	X	X	X	X	X	X	X	•	N/A	N/A	N/A
SEAT HEIGHT	X	N/A	X	X	X	X	X	X	X	N/A	X	X	X

ALWAYS make sure that the wheelchair is stable using the tilt-in-space.

Wheels may have to be repositioned depending on the degree of tilt-in-space required. ALWAYS ensure stability before using maximum amount of tilt-in-space (45° for 15-20-inch seat depths and 35° for 20 and 21-inch seat depths). Test wheelchair before it is occupied by the end user to ensure safety.

Changing the seat depth of the wheelchair changes the stability of the wheelchair. To maintain stability, reposition the wheels before using the wheelchair.

To maintain the stability of the wheelchair when moving the wheels to any position, the amount of tilt **MUST** be limited by adjusting the limit stops on the gas cylinders to prevent the wheelchair from tipping onto the anti-tippers.

Operating Information

Unless otherwise noted, all service and adjustments should be performed while the wheelchair is unoccupied.

To determine and establish your particular safety limits, practice bending, reaching and transferring activities in the presence of a qualified healthcare professional before attempting active use of the wheelchair.

The necessary back angle (90°, 99°, 108° or 120°) **MUST** be selected before repositioning the wheels and adjusting the limit stops on the gas cylinders.

Both gas cylinders **MUST** be operational before using the wheelchair. **DO NOT** operate the tilt-in-space if only one of the gas cylinders is operational.

DO NOT operate the tilt-in-space if the trigger release levers and cables are not properly adjusted to ensure that the tilt-in-space is locked in place when engaged.

ALWAYS verify the user's hand position prior to activating the tilt-in-space feature. **DO NOT** remove the side shrouds (see below) which cover the tilt mechanism. Failure to observe this warning can result in serious injury.

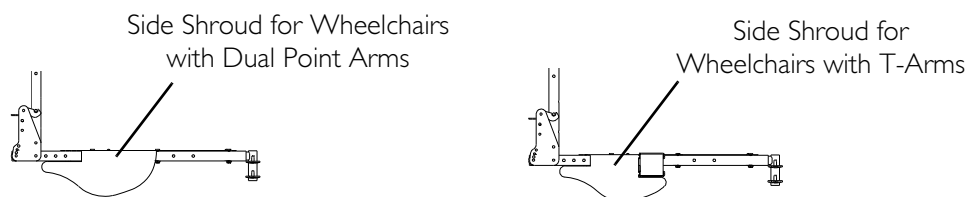

ALWAYS wear your seat/chest positioning strap. Inasmuch as the seat/chest positioning strap is an option on this wheelchair (you may order with or without the seat/chest positioning strap), Invacare strongly recommends ordering the seat/chest positioning strap as an additional safeguard for the wheelchair user.

ALWAYS check foam grips for looseness before using the wheelchair. If loose, contact a qualified technician for instructions.

DO NOT traverse, climb or go down ramps or slopes greater than 9°.

NEVER leave the occupied wheelchair unattended at any time, especially on an incline.

DO NOT attempt to reach objects if you have to move forward in the seat.

DO NOT attempt to reach objects if you have to pick them up from the floor by reaching down between your knees.

DO NOT lean over the top of the back upholstery/seating system. This will change your center of gravity and may cause you to tip over.

DO NOT shift your weight or sitting position toward direction you are reaching as wheelchair may tip over.

SECTION I—GENERAL GUIDELINES

Wheel locks are not brakes. DO NOT attempt to stop a moving wheelchair with the wheel locks.

Rear Wheel Configuration Only - DO NOT tip the wheelchair onto the wheels without assistance.

Front Wheel Configuration Only - DO NOT tip the wheelchair casters when using the front wheel configuration. Otherwise, injury or damage may occur.

DO NOT use an escalator to move a wheelchair between floors. Serious bodily injury may occur.

Before attempting to transfer in or out of the wheelchair, every precaution should be taken to reduce the gap distance. Turn both casters parallel to the object you are transferring onto. When transferring to and from the wheelchair, always engage both wheel locks.

DO NOT use wheelchair unless the tires have the proper tire pressure (p.s.i.). DO NOT overinflate the tires. Failure to follow these suggestions may cause the tire to explode and cause bodily harm. Recommended tire pressure is listed on the side wall of the tire.

DO NOT use any parts, accessories, or adapters other than those authorized by Invacare. Otherwise, the warranty is void.

DO NOT attempt to lift a wheelchair by lifting on any removable (detachable) parts. Lifting by means of any removable (detachable) parts of a wheelchair may result in injury to the user or damage to the wheelchair.

DO NOT use the spreader bar for lifting or transporting the wheelchair. DO NOT use the spreader bar as a weight bearing support.

DO NOT stand on the frame of the wheelchair.

Anti-tippers MUST be attached at all times.

DO NOT use the footplates as a platform. When getting in or out of the wheelchair, make sure that the footplates are in the upward position.

Weight Training

Invacare DOES NOT recommend the use of its wheelchairs as a weight training apparatus. Invacare wheelchairs have not been designed or tested as a seat for any kind of weight training. If occupant uses said wheelchair as a weight training apparatus, Invacare shall not be liable for bodily injury and the warranty is void.

Weight Limitation

Invacare Compass SPT has a weight limit of 250 lbs.

SECTION 2—SAFETY/HANDLING

Safety/Handling of Wheelchairs

“Safety and Handling” of the wheelchair requires the close attention of the wheelchair user as well as the assistant. This manual points out the most common procedures and techniques involved in the safe operation and maintenance of the wheelchair. It is important to practice and master these safe techniques until you are comfortable in maneuvering around the frequently encountered architectural barriers.

Use this information only as a “basic” guide. The techniques that are discussed on the following pages have been used successfully by many.

Individual wheelchair users often develop skills to deal with daily living activities that may differ from those described in this manual. Invacare recognizes and encourages each individual to try what works best for him/her in overcoming architectural obstacles that they may encounter, however ALL WARNINGS and CAUTIONS given in this manual MUST be followed. Techniques in this manual are a starting point for the new wheelchair user and assistant with “safety” as the most important consideration for all.

Stability and Balance

WARNING

ALWAYS wear your seat/chest positioning strap. Inasmuch as the seat/chest positioning strap is an option on this wheelchair (you may order with or without the seat/chest positioning strap), Invacare strongly recommends ordering the seat/chest positioning strap as an additional safeguard for the wheelchair user.

Anti-tippers MUST be attached at all times.

To assure stability and proper operation of your wheelchair, you must at all times maintain proper balance. Your wheelchair has been designed to remain upright and stable during normal daily activities as long as you do not move beyond the center of gravity.

Virtually all activities which involve movement in the wheelchair have an effect on the center of gravity. Invacare recommends using seat/chest positioning straps for additional safety while involved in activities that shift your weight.

DO NOT lean forward out of the wheelchair any further than the length of the armrests. Make sure the casters are pointing in the forward position whenever you lean forward. This can be achieved by advancing the wheelchair and then reversing it in a straight line.

The Invacare Compass SPT wheelchair should be operated by an assistant when the wheelchair is in any tilted position.

⚠ WARNING

DO NOT attempt to reach objects if you have to move forward in the seat or pick them up from the floor by reaching down between your knees.

The back height, seat depth, back angle, seating system, tilt angle, seat height, size/position of the wheels, size/position of the casters, as well as the user condition directly relate to the stability of the wheelchair. Any change to one or any combination of the eleven may cause the wheelchair to decrease in stability. These adjustments **MUST** be performed **ONLY** by a qualified technician.

NOTE: For this procedure, refer to FIGURE 2.1.

Many activities require the wheelchair owner to reach, bend and transfer in and out of the wheelchair. These movements will cause a change to the normal balance, the center of gravity and the weight distribution of the wheelchair. To determine and establish your particular safety limits, practice bending, reaching and transferring activities in several combinations in the presence of a qualified healthcare professional **BEFORE** attempting active use of the wheelchair.

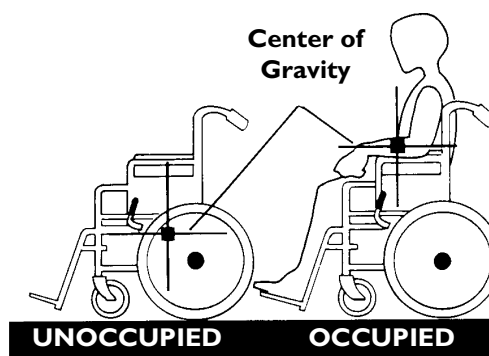

NOTE: Rear wheel configuration shown.

FIGURE 2.1 Stability and Balance

Proper positioning is essential for your safety. When reaching, leaning, or bending forward, it is important to use the casters as a tool to maintain stability and balance.

Coping With Everyday Obstacles

Coping with the irritation of everyday obstacles can be alleviated somewhat by learning how to manage your wheelchair. Keep in mind your center of gravity to maintain stability and balance.

A Note to Wheelchair Assistants

When assistance to the wheelchair user is required, remember to use good body mechanics. Keep your back straight and bend your knees whenever tipping the wheelchair or traversing curbs, or other impediments.

⚠ WARNING

DO NOT attempt to lift the wheelchair by any removable (detachable) parts. Lifting by means of any removable (detachable) parts of a wheelchair may result in injury to the user or damage to the wheelchair.

DO NOT use the spreader bar for lifting or transporting the wheelchair. DO NOT use the spreader bar as a weight bearing support.

Also, be aware of detachable parts such as armrests or legrests. These must NEVER be used to move the wheelchair or as lifting supports, as they may be inadvertently released, resulting in possible injury to the user and/or assistant(s).

When learning a new assistance technique, have an experienced assistant help you before attempting it alone.

Reaching, Leaning and Bending - Forward

⚠ WARNING

DO NOT attempt to reach objects if you have to move forward in the seat or pick them up from the floor by reaching down between your knees.

NOTE: For this procedure, refer to FIGURE 2.2.

Position the casters so that they are extended as far forward as possible and engage wheel locks.

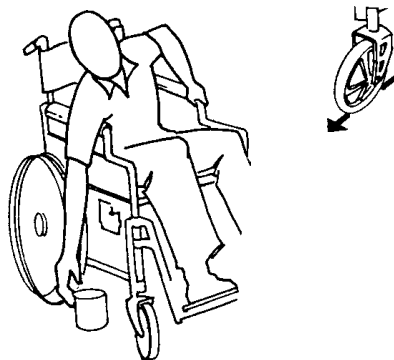

FIGURE 2.2 Reaching, Leaning and Bending - Forward

Reaching and Leaning - Backwards

⚠ WARNING

DO NOT lean over the top of the back upholstery. This will change your center of gravity and may cause you to tip over.

NOTE: For this procedure, refer to FIGURE 2.3.

Position wheelchair as close as possible to the desired object. Point casters forward to create the longest possible wheelbase. Reach back only as far as your arm will extend without changing your sitting position.

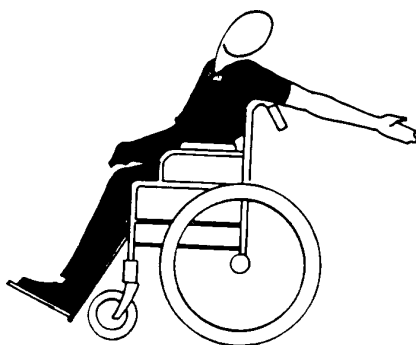

FIGURE 2.3 Reaching and Leaning - Backwards

Tipping - Rear Wheel Configuration Only

⚠ WARNING

DO NOT tip the wheelchair without assistance.

When tipping the wheelchair, an assistant should grasp the back of the wheelchair on a non-removable (non-detachable) part. Inform the wheelchair occupant before tipping the wheelchair and remind him/her to lean back. Be sure the occupant's feet and hands are clear of all wheels and/or pinch points.

After mastering the techniques of tipping the wheelchair, use one of the following methods to tackle curbs, short stairs, etc.

Tipping - Curbs: Method I - Wheelchair with Step Tubes

NOTE: For this procedure, refer to FIGURE 2.4 on page 21.

Place foot on the step tube and begin to tilt the wheelchair toward you. Apply a continuous downward motion until the balance point is achieved and the casters clear the curb. At this point, the assistant will feel a difference in the weight distribution.

⚠ WARNING

When lowering the casters of the wheelchair, DO NOT let the wheelchair drop the last few inches to the ground. This could result in injury to the occupant and/or damage to the wheelchair.

Roll the wheelchair forward and slowly lower the front of the wheelchair in one continuous movement onto the sidewalk. Push the wheelchair forward until the rear wheels roll up and over the curb.

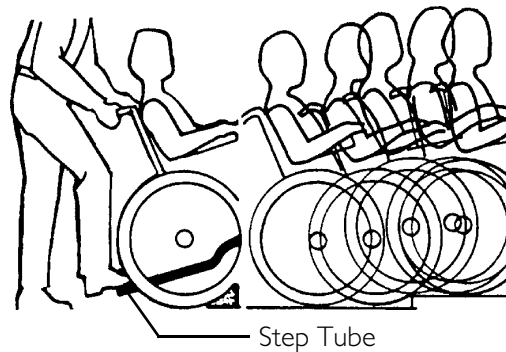

FIGURE 2.4 Tipping - Curbs: Method 1 - Wheelchair with Step Tubes

Tipping - Curbs: Method 2 - Wheelchair without Step Tube

NOTE: For this procedure, refer to FIGURE 2.5.

This method requires two assistants. The second assistant should be positioned at the front of the wheelchair lifting upward on a non-removable (non-detachable) part of the wheelchair frame when lifting the wheelchair and stabilizing the wheelchair when the wheelchair is being lowered to the ground.

The first assistant should stand on the sidewalk and turn the wheelchair so that the rear wheels are against the curb. Swivel the anti-tippers so the anti-tip wheels are towards the inside of the wheelchair. The wheelchair should be tilted back to the balance point and, in one continuous upward movement, the rear wheels should be pulled up and over the curb. DO NOT return the front casters to the ground until the wheelchair has been pulled backward far enough for the front casters to clear the edge of the curb.

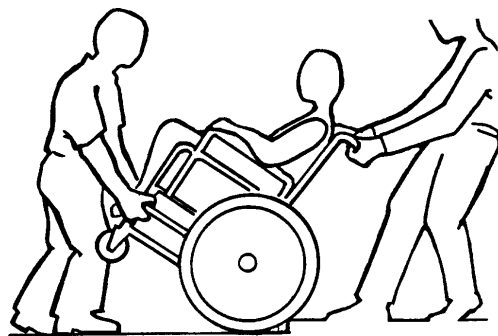

FIGURE 2.5 Tipping - Curbs: Method 2 - Wheelchair without Step Tube

⚠ WARNING

When lowering the front casters of the wheelchair, DO NOT let the wheelchair drop the last few inches to the ground. This could result in injury to the occupant and/or damage to the wheelchair.

Roll the wheelchair backward and **SLOWLY** lower the wheelchair in one continuous movement. Swivel the anti-tippers so the anti-tip wheels are towards the inside of the wheelchair.

Tipping - Front Wheel Configuration Only

⚠ WARNING

DO NOT tip the wheelchair onto the casters when using the front wheel configuration. Otherwise, injury or damage may occur.

Extreme caution is advised when it is necessary to move an occupied wheelchair up or down a curb. Invacare recommends that, if possible, a ramp should be used when a curb is encountered. Otherwise, if possible, the user should be removed from the wheelchair prior to moving. Invacare recommends using two assistants and making thorough preparations. Make sure to use ONLY secure, non-detachable parts for hand-held supports.

Follow this procedure for moving the wheelchair up or down a curb when a ramp is NOT available:

1. Position the wheelchair as close to the curb as possible.
2. One assistant (in the rear) and another assistant (in the front) should each securely grasp a non-removable (non-detachable) part of the wheelchair.
3. The wheelchair should be moved up or down the curb.

Stairways - Rear Wheel Configuration Only

⚠ WARNING

ALWAYS wear your seat/chest positioning strap. Inasmuch as the **SEAT/CHEST POSITIONING STRAP** is an option on this wheelchair (You may order with or without the Seat/Chest Positioning Strap), Invacare strongly recommends ordering the Seat/Chest Positioning Strap as an additional safeguard for the wheelchair user.

DO NOT attempt to lift a wheelchair by lifting on any removable (detachable) parts. Lifting by means of any removable (detachable) parts of a wheelchair may result in injury to the user or damage to the wheelchair.

DO NOT use the spreader bar for lifting or transporting the wheelchair. **DO NOT** use the spreader bar as a weight bearing support.

⚠ WARNING

Extreme caution is advised when it is necessary to move an occupied wheelchair up or down the stairs. Invacare recommends that, if possible, the user be removed from the wheelchair prior to moving. Invacare recommends using two assistants and making thorough preparations. Make sure to use ONLY secure, non-detachable parts for hand-held supports.

Follow this procedure for moving the wheelchair between floors when an elevator is NOT available:

1. If necessary, swivel the anti-tippers so the wheels are facing in.
2. After the wheelchair has been tilted back to the balance point, one assistant (in the rear) backs the wheelchair up against the first step, while securely grasping a non-removable (non-detachable) part of the wheelchair for leverage.
3. The second assistant, with a firm hold on a non-detachable part of the framework, lifts the wheelchair up and over the stair and steadies the wheelchair as the first assistant places one foot on the next stair and repeats STEP 1.
4. The wheelchair should not be lowered until the last stair has been negotiated and the wheelchair has been rolled away from the stairway.
5. If necessary, swivel the anti-tippers so the wheels are facing the rear.

Stairways - Front Wheel Configuration Only

⚠ WARNING

DO NOT tip the wheelchair when using the front wheel configuration. Otherwise, injury or damage may occur.

Extreme caution is advised when it is necessary to move an occupied wheelchair up or down the stairs. Invacare recommends that, if possible, the user be removed from the wheelchair prior to moving. Invacare recommends using two assistants and making thorough preparations. Make sure to use ONLY secure, non-detachable parts for hand-held supports.

Follow this procedure for moving the wheelchair between floors when an elevator is NOT available:

1. Two assistants (at the front and rear of the wheelchair), with a firm hold on a non-detachable part of the framework, should lift the wheelchair up and over each stair.
2. The wheelchair should not be lowered until the last stair has been negotiated and the wheelchair has been rolled away from the stairway.

Escalators

⚠ WARNING

DO NOT use an escalator to move a wheelchair between floors. Serious bodily injury may occur.

Transferring To and From Other Seats

⚠ WARNING

BEFORE attempting to transfer in or out of the wheelchair, every precaution should be taken to reduce the gap distance. Turn both casters parallel to the object you are transferring onto. Also be certain the wheel locks are engaged to help prevent the wheels from moving.

CAUTION

When transferring, position yourself as far back as possible in the seat. This will help prevent broken screws, damaged upholstery and the possibility of the wheelchair tipping forward.

NOTE: For this procedure, refer to FIGURE 2.6.

NOTE: This activity may be performed independently provided you have adequate mobility and upper body strength.

Position the wheelchair as close as possible along side the seat to which you are transferring, with the casters pointing parallel to it. Remove or flip up the armrest. Engage wheel locks. Shift body weight into seat with transfer.

During independent transfer, little or no seat platform will be beneath you. Use a transfer board if at all possible.

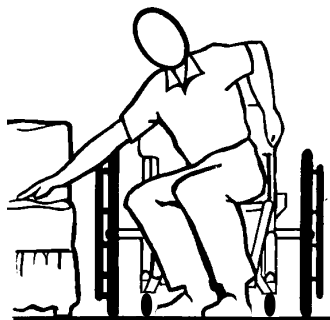

FIGURE 2.6 Transferring To and From Other Seats

SECTION 3—SAFETY INSPECTION CHECKLIST

NOTE: Every six months take your wheelchair to a qualified technician for a thorough inspection and servicing. Regular cleaning will reveal loose or worn parts and enhance the smooth operation of your wheelchair. To operate properly and safely, your wheelchair must be cared for just like any other vehicle. Routine maintenance will extend the life and efficiency of your wheelchair.

Safety Inspection Checklists

Initial adjustments should be made to suit your personal body structure needs and preference. Thereafter follow these maintenance procedures:

CAUTION

As with any vehicle, the wheels and tires should be checked periodically for cracks and wear, and should be replaced.

Inspect/Adjust Initially

- Ensure wheelchair rolls straight (no excessive drag or pull to one side).
- Inspect clothing guards for bent or protruding metal.
- Ensure that all fasteners on clothing guards are secure.
- Ensure arms are secure but easy to release and adjustment levers engage properly.
- Ensure adjustable height arms operate and lock securely.
- Ensure armrest upholstery has no rips.
- Ensure armrest pad sits flush against arm tube.
- Ensure hand grips are not loose.
- Ensure seat and/or back upholstery have no rips.
- Ensure trigger release lever cables and handles return when released.
- Inspect handrims for signs of rough edges or peeling finish.
- Ensure there is no excessive side movement or binding when drive wheels are lifted and spun.
- Ensure that the casters are free of debris.
- Ensure sealed bearings and axle nut tension are correct.
- Adjust bearing system if wheel wobbles noticeably or binds to a stop.
- Ensure wheel/fork assembly has proper tension when caster is spun. Caster should come to a gradual stop.
- Loosen/tighten caster locknut if wheel wobbles noticeably or binds to a stop.

SECTION 3—SAFETY INSPECTION CHECKLIST

- Ensure all caster/wheel/fork/headtube fasteners are secure.
- Ensure wheel locks do not interfere with tires when rolling.
- Ensure wheel lock pivot points are free of wear and looseness.
- Ensure wheel locks are easy to engage.
- Inspect tires for flat spots and wear.
- Check pneumatic tires for proper inflation.

Inspect/Adjust Weekly

- Ensure wheelchair rolls straight (no excessive drag or pull to one side).
- Ensure hand grips are not loose.
- Ensure wheel/fork assembly has proper tension when caster is spun. Caster should come to a gradual stop.
- Ensure that the casters are free of debris.
- Ensure all caster/wheel/fork/headtube fasteners are secure.
- Check pneumatic tires for proper inflation.
- Check that all labels are present and legible. Replace if necessary.

Inspect/Adjust Monthly

- Ensure sealed bearings and axle nut tension are correct..
- Ensure there is no excessive side movement or binding when drive wheels are lifted and spun.
- Adjust bearing system if wheel wobbles noticeably or binds to a stop.
- Inspect tires for flat spots and wear.
- Ensure wheel locks do not interfere with tires when rolling.
- Ensure wheel lock pivot points are free of wear and looseness.
- Ensure wheel locks are easy to engage.
- Ensure that the casters are free of debris.
- Inspect axles to ensure they are free from dirt, lint, etc.
- Inspect tilt slides and roller bearings to ensure they are free from dirt, lint, etc.
- Inspect seat positioning strap for any signs of wear. Ensure buckle latches. Verify hardware that attaches strap to frame is secure and undamaged. Replace if necessary.

Inspect/Adjust Periodically

- Inspect clothing guards for bent or protruding metal.
- Ensure that all fasteners on clothing guards are secure.
- Ensure arms are secure but easy to release and adjustment levers engage properly.
- Ensure adjustable height arms operate and lock securely.
- Ensure armrest upholstery has no rips.
- Ensure armrest pad sits flush against arm tube.
- Ensure trigger release lever cables and handles return when released..
- Ensure that the casters are free of debris.
- Ensure sealed bearings and axle nut tension are correct.
- Inspect handrims for signs of rough edges or peeling finish.
- Clean upholstery and armrests.
- Clean and wax all parts.
- Check that all labels are present and legible. Replace if necessary.

Troubleshooting - Mechanical

CHAIR VEERS LEFT/RIGHT	SLUGGISH TURN/PERFORMANCE	CASTERS FLUTTER	SQUEAKS AND RATTLES	LOOSENESS IN CHAIR	SOLUTIONS
X	X				If pneumatic tires, check for correct and equal pressure.
	X	X	X	X	Check for loose stem nuts/bolts.
X		X			Check that casters contact ground at the same time.

Maintenance/Transporting

⚠ WARNING

After any adjustments, repair or service and BEFORE use, make sure all attaching hardware is tightened securely - otherwise injury or damage may result.

CAUTION

DO NOT over tighten hardware attaching to the frame. This could cause damage to the frame tubing.

Suggested Maintenance Procedures

1. Keep quick-release axles free of dirt and lint to ensure positive locking and proper operation. Refer to Adjusting the Quick-Release Axle on page 59.
-

⚠ WARNING

DO NOT use WD-40[®], 3-in-1 oil[®], or other penetrating lubricants on quick-release axles. Otherwise, binding and/or damage to the wheelchair may occur.

2. Clean quick-release axles once a week with a Teflon[®] lubricant.
-

⚠ WARNING

DO NOT use the wheelchair unless it has the proper tire pressure (p.s.i.). DO NOT overinflate the tires. Failure to follow these suggestions may cause the tire to explode and cause bodily harm.

3. If tires are pneumatic, recommended tire pressures will be listed on the side wall of the tires.
 4. Periodically adjust wheel locks as tires wear. Refer to Wheel Lock Adjustment on page 61.
 5. Make sure that all bolts are tight before operating wheelchair.
-

⚠ WARNING

As with any vehicle, the wheels, casters and tires should be checked periodically for cracks and wear, and should be replaced.

6. The wheels and tires should be checked periodically for cracks and wear, and should be replaced.
 7. Periodically check handrims to ensure they are secured to the wheels. Refer to Replacing Wheel Handrim on page 60.
 8. Check upholstery for sagging, rips or tears.
-

9. Periodically check gas cylinders for oil leaks. If oil leak is detected, gas cylinder(s) should be replaced.
10. Replace any labels that are missing, worn or torn. Refer to Label Locations on page 11 for a listing of the labels and their locations.

Transporting the Invacare Compass SPT

1. Remove the seating system.
2. Remove the footrests. Refer to Front Riggings on page 30.
3. Remove the wheels. Refer to Installing/Removing Rear Wheels on page 58.
4. Remove the armrests. Refer to Installing/Removing T-Arms on page 42.
5. Remove the stroller handle (if applicable). Refer to Back/Seat on page 47.
6. Pull the back release cord and fold the back towards the front of the wheelchair. Refer to Back/Seat on page 47.

SECTION 4—FRONT RIGGINGS

⚠ WARNING

After making adjustments, always make sure that parts are properly tightened **BEFORE** using the wheelchair.

Installing/Removing Swingaway Front Riggings

CAUTION

If front riggings are used, then the seat **MUST** be adjusted to the highest mounting position - otherwise damage may occur.

NOTE: For this procedure, refer to FIGURE 4.1.

Installing

1. Turn front rigging to the side (open footplate is perpendicular to wheelchair) and position mounting holes in the front rigging hinge plates with hinge pins on the wheelchair frame.
2. Install the front rigging hinge plates onto the hinge pins on the wheelchair frame.
3. Push the front rigging towards the inside of the wheelchair until it locks into place.

NOTE: The footplate will be on the inside of the wheelchair when locked in place.

4. Repeat STEPS 1-3 for opposite side of wheelchair.
5. If necessary, adjust the footrest height. Refer to [Installing/Removing Swingaway Front Riggings](#) on page 30

Removing

1. Pull the front rigging release lever and rotate the footrest outward.
2. Lift up on front rigging and remove from the wheelchair.
3. Repeat STEPS 1-2 for opposite side of wheelchair.

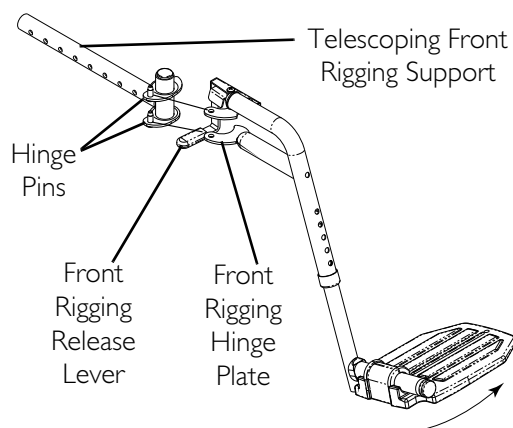

FIGURE 4.1 Installing/Removing Swingaway Front Riggings

Installing/Removing Lift-Off Footrest

NOTE: For this procedure, refer to FIGURE 4.2.

Installing

1. Insert the footrest assembly mounting pins into the mounting tube of the wheelchair frame.
2. Repeat STEP 1 for the other footrest assembly.
3. If necessary, adjust the footrest height. Refer to [Adjusting Footrest Height](#) on page 31.

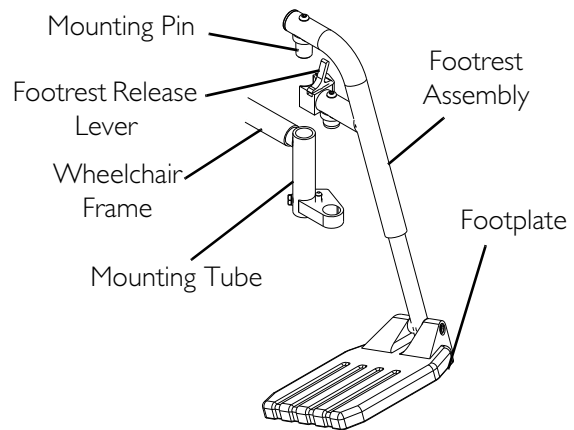

FIGURE 4.2 Installing/Removing Lift-Off Footrest

Removing

1. Push the footrest release lever inward and lift footrest upward.
2. Repeat STEP 1 for opposite side, if necessary.

Adjusting Footrest Height

Height Adjustment Ranges

FOOTREST TYPE	ADJUSTMENT RANGE
60°	13-17 inches
70°	13-17 inches
90°	5-8 inches
90°	5-11 inches (with 3-inch extension)

60°, 70° and 70° Taper

NOTE: For this procedure, refer to FIGURE 4.3 on page 32.

1. Remove the footrest from the wheelchair. Refer to [Installing/Removing Swingaway Front Riggings](#) on page 30.
2. Remove the hex screw and covered spacer and slide the footrest up or down on its mounting tube until the desired footrest height is achieved.
3. Reassemble the hex screw and covered spacer through the footrest upper support and mounting tube (FIGURE 4.3).

SECTION 4—FRONT RIGGINGS

4. Securely tighten the hex screw and coved spacer.
5. Install the footrest assembly onto the wheelchair. Refer to [Installing/Removing Swingaway Front Riggings](#) on page 30.
6. Repeat STEPS 1-5 for the opposite side of the wheelchair, if necessary.

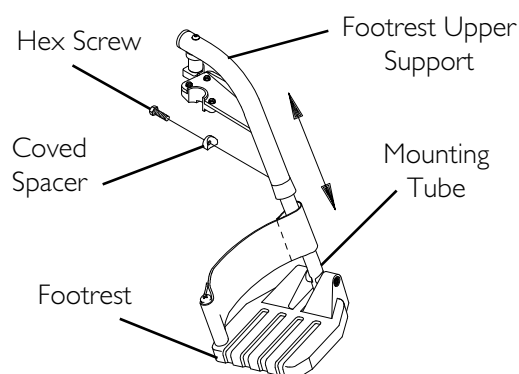

FIGURE 4.3 Adjusting Footrest Height - 60°, 70° and 70° Taper

70° MFX, 90°, 70° LIFT and 90° LIFT Footrests

NOTE: For this procedure, refer to FIGURE 4.4.

1. Remove any accessories that are attached to the footrests.
2. Remove the socket bolt, coved washer and locknut that secure the footplate to the footrest support.
3. Reposition the footplate to the desired height.
4. Reinstall the socket bolt through the mounting holes of the footplate and footrest support.

⚠ WARNING

DO NOT overtighten socket bolt and locknut. Footrest **MUST** be able to rotate upward from the horizontal to the vertical position.

5. Secure the footplate to the footrest support with the coved washer and locknut.

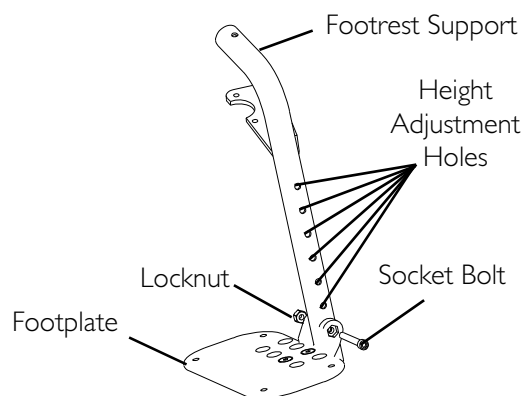

FIGURE 4.4 Adjusting Footrest Height - 70° MFX, 90°, 70° LIFT and 90° LIFT Footrests

Model PHW93 and PH904A Front Riggings

NOTE: For this procedure, refer to FIGURE 4.5 on page 33.

1. Remove any accessory from the footrest(s).
2. Remove the footrest from the wheelchair. Refer to [Installing/Removing Swingaway Front Riggings](#) on page 30.

NOTE: Lay footrest on a flat surface to simplify procedure.

3. Remove the hex bolt, coved washers and locknut that secure the lower footrest to the footrest support.
4. Reposition the lower footrest to the desired height.
5. Reinstall hex bolt, coved washers and locknut that secure lower footrest to footrest support. Tighten securely.
6. Repeat STEPS 1-5 for the opposite side of the wheelchair footrest, if necessary.
7. Reinstall the footrest(s) onto the wheelchair. Refer to [Installing/Removing Swingaway Front Riggings](#) on page 30.
8. Reinstall any accessory onto the footrest(s).

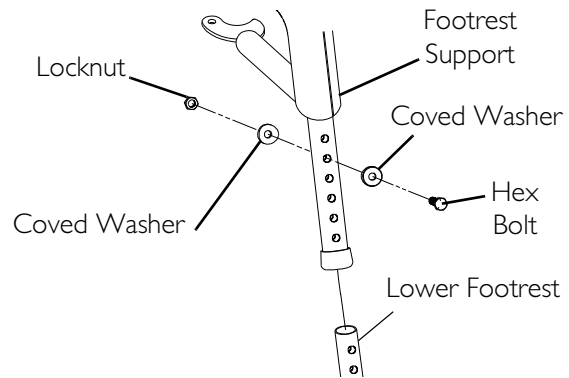

FIGURE 4.5 Adjusting Footrest Height - Model PHW93 and PH904A Front Riggings

Installing Adjustable Angle Flip-up Footplate Hinge

NOTE: For this procedure, refer to FIGURE 4.6.

1. Position the adjustable angle flip-up footplate hinge on the footrest support tube at the desired height.
2. Position the hardware on the footrest support as shown in FIGURE 4.6.
3. Flip the footplate hinge to the UP position.

NOTE: The footplate hinge will fall to the DOWN position.

4. Tighten the socket screw and locknut that secure the footplate hinge to the footrest support until the footplate hinge remains in the up position.
5. Check the up and down motion of the footplate hinge to make sure the user of the wheelchair can operate the footplates easily.

NOTE: If the footplate's motion is too tight, loosen the socket screw and locknut approximately ¼-turn.

NOTE: If the footplate's motion is too loose, tighten socket screw and locknut approximately ¼-turn.

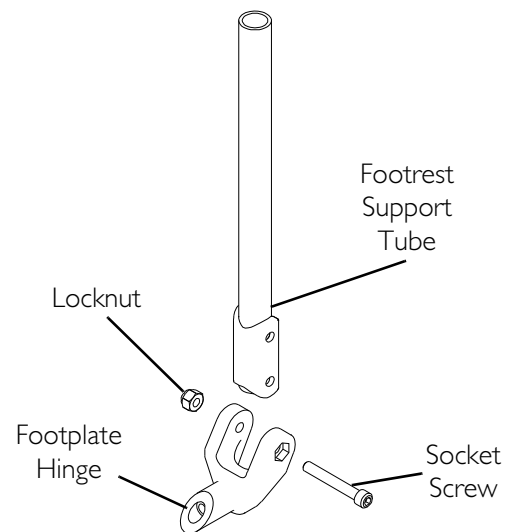

FIGURE 4.6 Installing Adjustable Angle Flip-up Footplate Hinge

Adjusting Adjustable Angle Flip-up Footplates

⚠ WARNING

When determining the angle of the footplates, make sure the rear of the footplates do not interfere with the movement of the front casters. Otherwise, injury or damage may occur.

NOTE: For this procedure, refer to FIGURE 4.7

Depth Adjustment

1. Remove the two flat screws and locknuts that secure footplate to the half clamp.

NOTE: Observe the angle of the footplate for reinstallation.

2. Move the footplate to one of four mounting positions.

NOTE: If desired depth is still not obtained, rotate the half clamp on the footplate hinge 180°.

3. Retighten the two flat screws and locknuts.

NOTE: The setting for positioning the footplate on the half clamp may vary for each footplate.

4. Repeat STEPS 1-3 for opposite footplate, if desired.

Angle Adjustment

1. Loosen, but DO NOT remove the adjustment screw in the half clamp.
2. Position the footplate to the necessary angle to accommodate the user (Detail "A" of FIGURE 8).
3. Retighten the adjustment screw. Torque to over 90 in.-lbs., but no more than 300 in.-lbs.
4. Repeat STEPS 1-3 for opposite footplate, if desired.

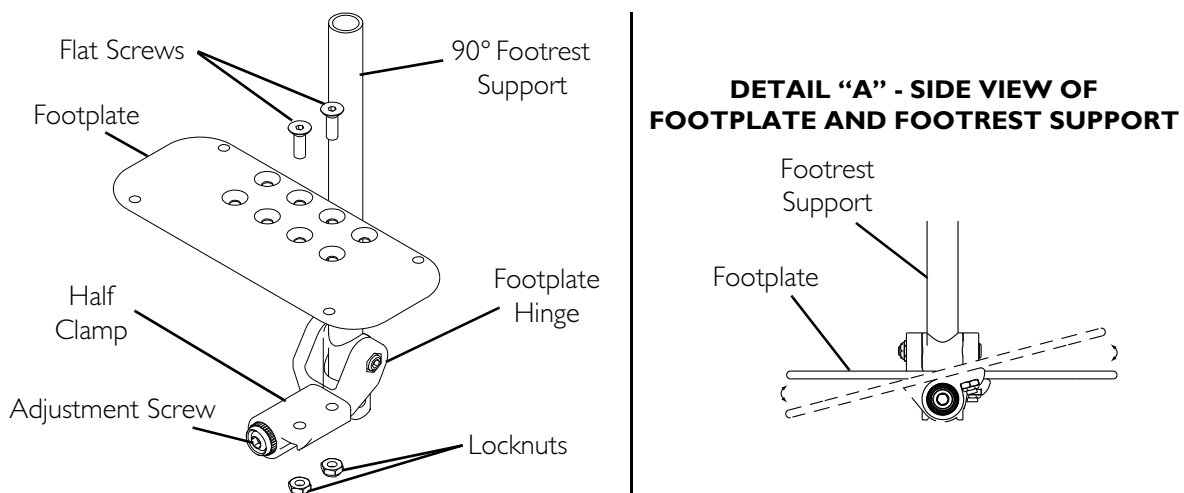

FIGURE 4.7 Adjusting Adjustable Angle Flip-up Footplates

Composite/Articulating Footplate Heel Loop Replacement

NOTE: For this procedure, refer to FIGURE 4.8.

Disassembly

Composite.

1. Remove the hex screw and covered spacer that secure the lower footrest assembly to the swing away footrest assembly.
2. Remove the lower footrest assembly.
3. Remove the mounting screw and locknut that secure the heel loop to the footrest.
4. Slide heel loop off of the footrest.

Articulating.

1. Remove the mounting screws, washers and spacers that secure the heel loop to the articulating footplate.

Reassembly

1. Replace heel loop.
2. Reverse the disassembly procedures.

NOTE: When securing the heel loop to the footrest assembly, tighten mounting screw until the spacer is secure.

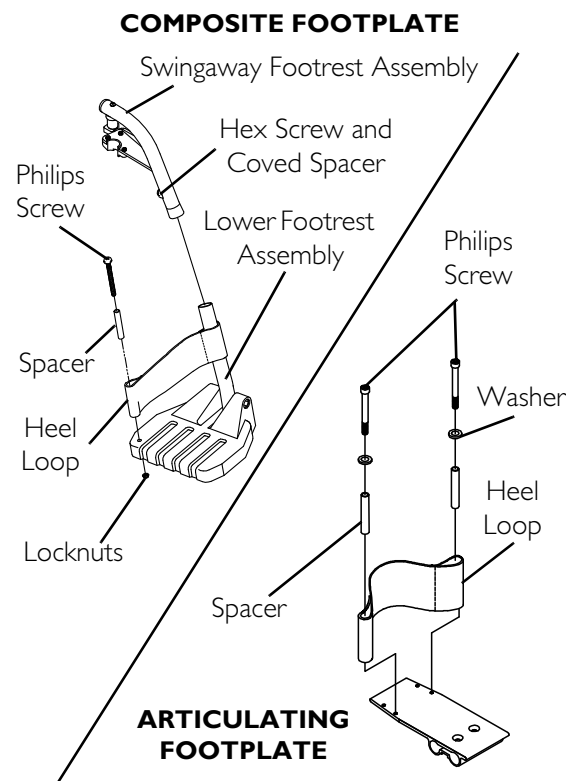

FIGURE 4.8 Composite/Articulating Footplate Heel Loop Replacement

Installing/Removing Elevating Legrests

NOTE: For this procedure, refer to FIGURE 4.9 on page 36.

Installing

1. Place elevating legrest on the outside of the wheelchair and insert mounting pin into the mounting tube.
2. Rotate elevating legrest toward the inside of the wheelchair until it locks in place.

NOTE: The calfpad of the legrest will be on the inside of the wheelchair when locked in place.

3. Repeat STEPS 1-3 for the other elevating legrest assembly.

Removing

1. Push the legrest release handle inward while rotating the elevating legrest outward.
2. Lift the legrest assembly out of the mounting tube of the wheelchair frame.
3. Repeat STEPS 1-2 for opposite side, if necessary.

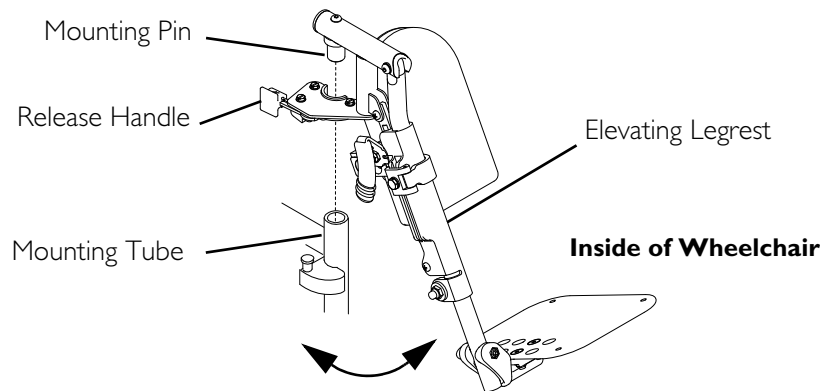

NOTE: The mounting tube will be part of the seat frame or wheelchair front frame depending on wheelchair model.

FIGURE 4.9 Replacing Sector Block

Raising/Lowering the Elevating Legrest

NOTE: For this procedure, refer to FIGURE 4.10.

1. Perform one of the following:
 - Raising: Lift legrest assembly up to desired height.
 - Lowering: Lift elevating legrest assembly up with one hand. While supporting the elevating legrest assembly (and user's leg), pull release lever up with other hand and lower legrest assembly to desired height.

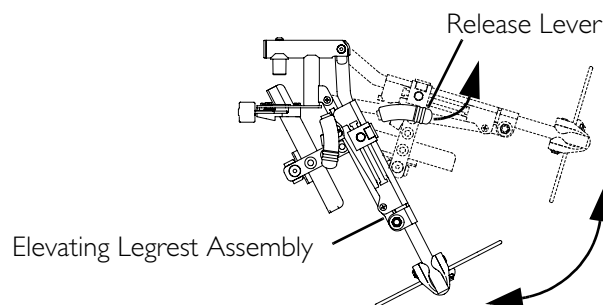

FIGURE 4.10 Raising/Lowering the Elevating Legrest

Adjusting Footplate Height and Calfpad Height/Depth

NOTE: For this procedure, refer to FIGURE 4.11.

Adjusting the Footplate Height

1. Loosen locknut and washer securing the slide tube to the elevating legrest.
2. Reposition footplate to desired height securely tighten locknut and washer.
3. If necessary, repeat STEPS 1-2 to adjust remaining footplate height.

Adjusting Calfpad Height

1. Loosen the mounting bolt and washer that secure the calfpad bracket to the elevating legrest assembly.
2. Slide the calfpad bracket up or down until the desired calfpad height is obtained.
3. Tighten the mounting bolt and washer securing the calfpad bracket to the elevating legrest assembly.
4. If necessary, repeat STEPS 1-3 to adjust remaining calfpad bracket.

Adjusting Calfpad Depth

1. Remove the mounting screw, spacer and locknut that secure the calfpad to the calfpad bracket.
2. Insert mounting screw through one of four calfpad bracket mounting holes.
3. Using the mounting screw spacer and locknut, secure the calfpad to the calfpad bracket.
4. If necessary, repeat STEPS 1-3 to adjust remaining calfpad assembly.

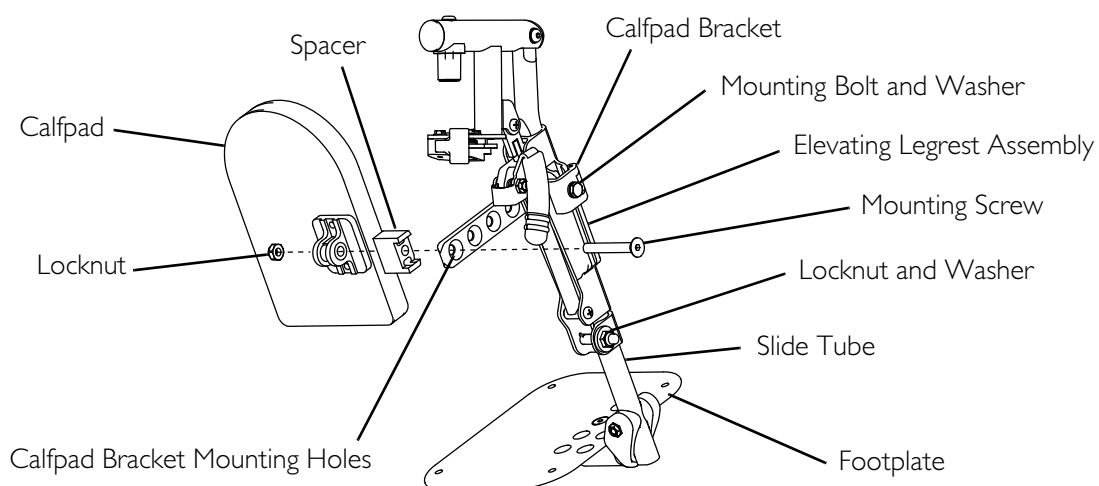

FIGURE 4.11 Adjusting Footplate Height and Calfpad Height/Depth

Composite/Articulating Footplate Heel Loop Replacement

NOTE: For this procedure, refer to FIGURE 4.12.

Disassembly

Composite

1. Remove the hex screw and coved spacer that secure the lower footrest assembly to the swing away footrest assembly.
2. Remove the lower footrest assembly.
3. Remove the mounting screw and locknut that secure the heel loop to the footrest.
4. Slide heel loop off of the footrest.

Articulating

1. Remove the mounting screws, washers and spacers that secure the heel loop to the articulating footplate.

Reassembly

1. Replace heel loop.
2. Reverse the disassembly procedures.

NOTE: When securing the heel loop to the footrest assembly, tighten mounting screw until the spacer is secure.

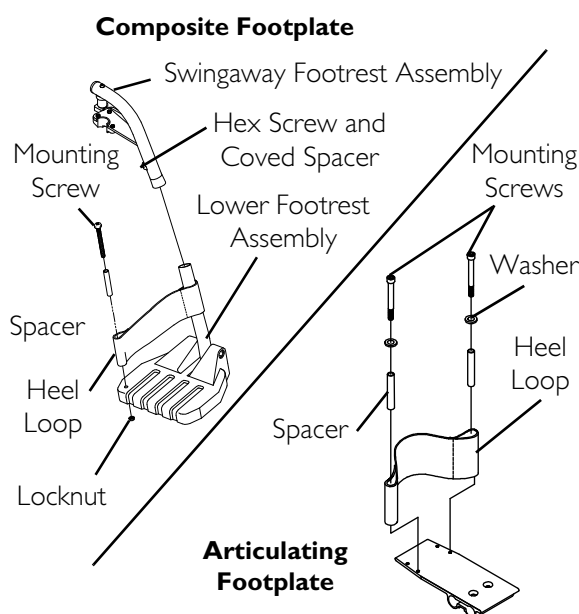

FIGURE 4.12 Composite/Articulating Footplate Heel Loop Replacement

Replacing Sector Block

NOTE: For this procedure, refer to FIGURE 4.13.

1. Remove the hex screw and washer that secure the existing sector block to the front rigging support tube.
2. Position the new sector block on the front rigging support tube. Make sure the locking pin is facing up.
3. Secure the new sector block to the front rigging support tube with the existing hex screw and washer.

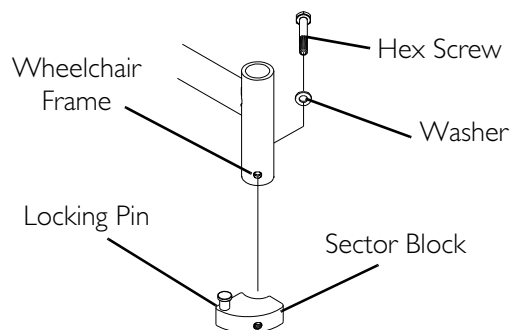

FIGURE 4.13 Replacing Sector Block

Installing Impact Guards/Calf Strap/H-Calf Strap

NOTE: For this procedure, refer to FIGURE 4.14.

NOTE: Impact guards are standard equipment on Model ST footrests. No assembly is required.

1. Remove impact guard/calf strap from packaged container.
2. Secure the impact guards to the footrest frame.
3. Secure the calf strap around the footrest frame (with the impact guards attached).

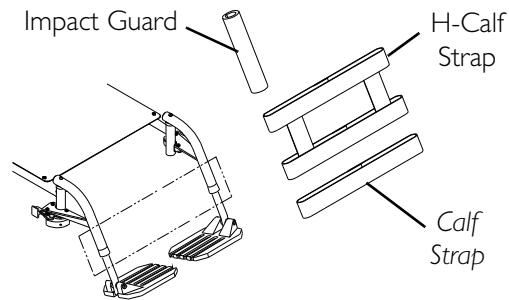

FIGURE 4.14 Installing Impact Guards/Calf Strap/H-Calf Strap

SECTION 5—ARMS

⚠ WARNING

After any adjustments, repair or service and before use, make sure all attachment hardware is tightened securely - otherwise, injury or damage may result.

DO NOT attempt to lift or tilt a wheelchair by using any removable (detachable) parts. Lifting by means of any removable (detachable) parts of a wheelchair may result in injury to the user or damage to the wheelchair.

Using/Adjusting Dual Point Arms

⚠ WARNING

Make sure the locking mechanism is secured before using the wheelchair.

NOTE: For this procedure, refer to FIGURE 5.1 on page 41.

Installing Armrest

1. Unlock armrest assembly by flipping the arm assembly release lever located on the side rail to the up (horizontal) position as shown in Detail "A".

NOTE: Armrest locks MUST be in the unlocked position when placing arm into the arm sockets.

2. Install armrest assembly into the arm sockets.
3. When installed, lock the armrest assembly by pressing the release lever into the down (vertical) position as shown in Detail "A".
4. Repeat STEPS 1-3 for the opposite side of the wheelchair.
5. If necessary, adjust the armrest height. Refer to Adjusting Armrest on page 40.

Removing Armrest

1. Unlock armrest assembly by flipping the arm assembly release lever located on the side rail to the up (horizontal) position as shown in Detail "A".
2. Pull up on the armrest assembly to remove the armrest from the arm socket.
3. Repeat STEPS 1-2 for opposite side of wheelchair, if necessary.

Adjusting Armrest

1. Unlock the armrest assembly by flipping the armrest release lever on the top front of the arm to the up (horizontal) position as shown in Detail "A".
2. Adjust armrest assembly to desired height.

3. Lock the armrest assembly by pressing the release lever into the down (vertical) position as shown in Detail "A".
4. Pull up on the armrest assembly to ensure the armrest is locked in place.
5. Repeat STEPS 1-4 for opposite side of wheelchair, if necessary.

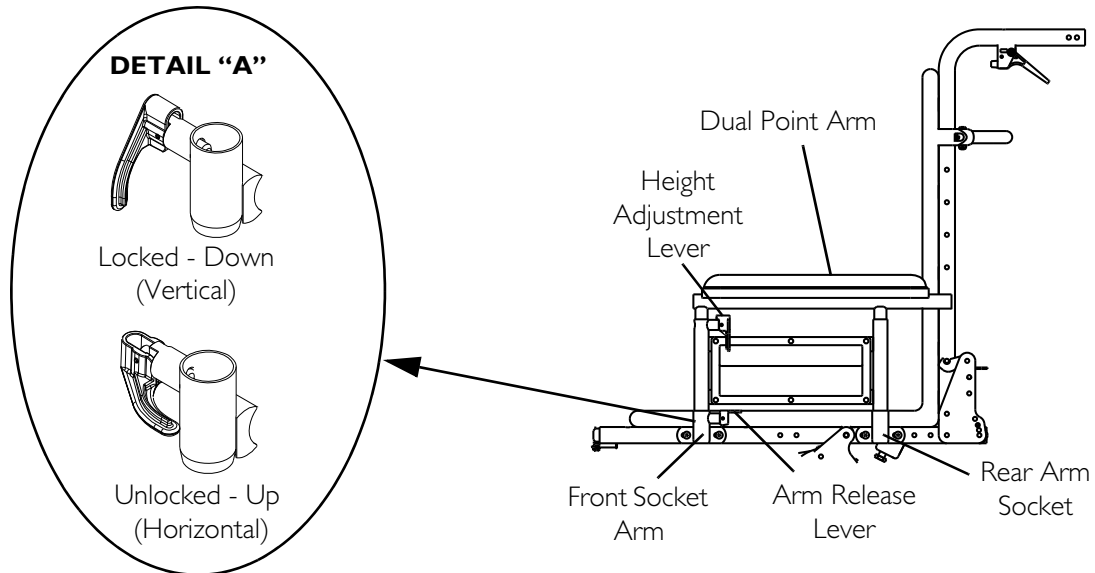

FIGURE 5.1 Using/Adjusting Dual Point Arms

Replacing Dual Point Arm Pad

NOTE: For this procedure, refer to FIGURE 5.2 on page 41.

1. Remove the mounting screws that secure the arm pad to the armrest assembly.
2. Replace arm pad and securely tighten with the existing mounting screws.

Replacing Dual Point Arm Clothing Guards

NOTE: For this procedure, refer to FIGURE 5.2 on page 41.

NOTE: This procedure is for fixed height dual point arms ONLY.

1. Remove the four screws that secure the existing clothing guard to the armrest assembly.

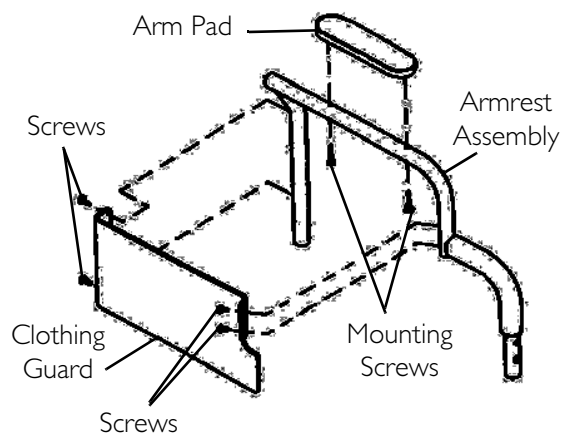

FIGURE 5.2 Replacing Dual Point Arm Pad/Replacing Dual Point Arm Clothing Guards

2. Replace the existing clothing guard with the new clothing guard and securely tighten with the existing hardware.
3. Repeat STEPS 1-2 for the opposite side if necessary.

Installing/Removing T-Arms

NOTE: For this procedure, refer to FIGURE 5.3.

Installing T-Arms

1. Position the T-Arm over the T-Arm socket on the wheelchair frame.

NOTE: Make sure the locking lever is towards the front of the wheelchair.

2. Slide T-Arm into T-Arm socket until the locking lever is in the slot in the T-Arm socket and an audible “click” is heard.
3. Pull up on T-Arm to make sure T-Arm is locked in place.

NOTE: If the T-Arm does not slide in the T-Arm socket as desired, adjust the T-Arm socket. Refer to [Adjusting T-Arm Sockets](#) on page 45.

4. Adjust the T-Arm for desired height, width and depth, if necessary. Refer to [Adjusting The T-Arms](#) on page 43.
5. Repeat STEPS 1-4 for opposite side of wheelchair.

Removing T-Arms

1. Press the locking lever in and lift the T-Arm straight up and out of the T-Arm socket.

NOTE: If the T-Arm does not slide up and down in the T-Arm socket as desired, adjust the T-Arm socket. Refer to [Adjusting T-Arm Sockets](#) on page 45.

2. Repeat STEP 1 for opposite side of the wheelchair.

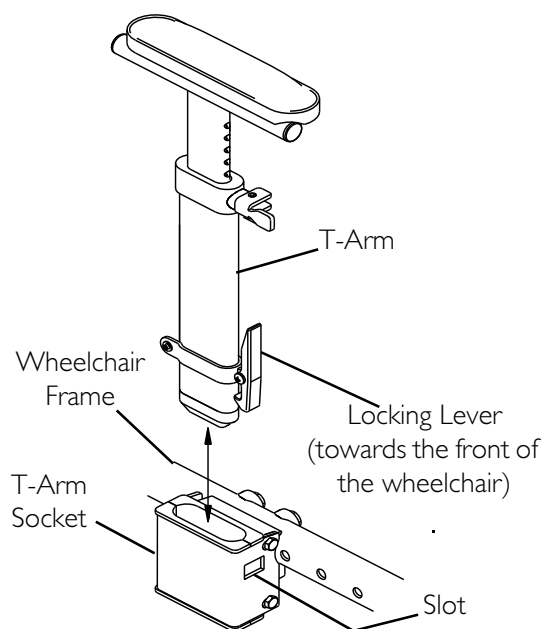

FIGURE 5.3 Installing/Removing T-Arms

Adjusting The T-Arms

Adjusting T-Arm Height

NOTE: For this procedure, refer to FIGURE 5.4.

1. Unlock the T-Arm by flipping the T-Arm release lever towards the inside of the wheelchair.

NOTE: If necessary, pull the T-Arm release lever out and rotate 180° so it can be flipped towards the outside of the wheelchair.

2. Slide the T-Arm to one of:
 - A. Low Height T-Arms - Nine positions.
 - B. High Height T-Arms - Seven positions.
3. If the inside T-Arm post does not slide up and down in the outside T-Arm post as desired, perform one of the following:
 - Tighten - Tightening the set screws on the outside T-Arm post will make it more difficult to move the inside T-Arm post up and down.
 - Loosen - Loosening the set screws on the outside T-Arm post will make it easier to move the inside T-Arm post up and down.
4. Lock the T-Arm by flipping the T-Arm release lever towards the front of the wheelchair.

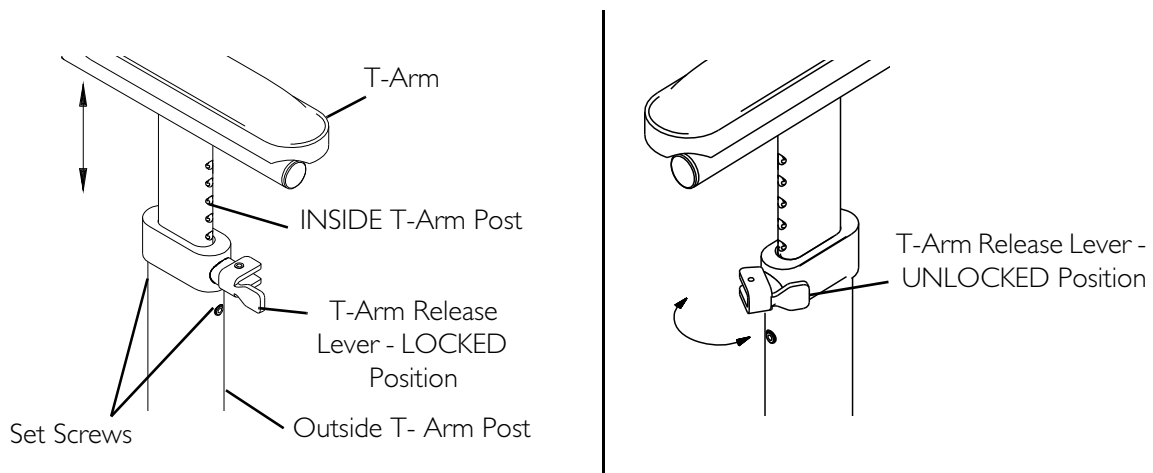

FIGURE 5.4 Adjusting T-Arm Height

Adjusting T-Arm Width

NOTE: For this procedure, refer to FIGURE 5.5.

1. Remove the two mounting screws that secure the arm pad to the arm tube.
2. Turn the arm pad around and reposition the arm pad on the arm tube.
3. Re-secure the arm pad to the arm tube with the two mounting screws. Tighten securely.
4. Repeat for the opposite side, if necessary.

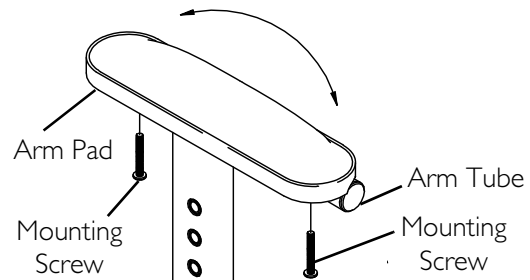

FIGURE 5.5 Adjusting T-Arm Width

Adjusting T-Arm Depth

NOTE: For this procedure, refer to FIGURE 5.6.

1. Remove the two mounting screws that secure the arm pad to the arm tube.
2. Remove the two socket screws that secure the arm tube to the T-Arm post.
3. Reposition the arm tube on the T-Arm post:
 - A. Desk Length Arms - to one of three positions depending on the desired arm pad depth.
 - B. Full Length Arms - to one of five positions depending on the desired arm pad depth.

NOTE: Two additional positions are obtainable by turning the arm tube 180°.

4. Re-secure the arm tube to the T-Arm post with the two socket screws. Torque to 60-70 in.-lbs.
5. Reattach the arm pad to the arm tube with the two mounting screws. Tighten securely.
6. Repeat for the opposite side, if necessary.

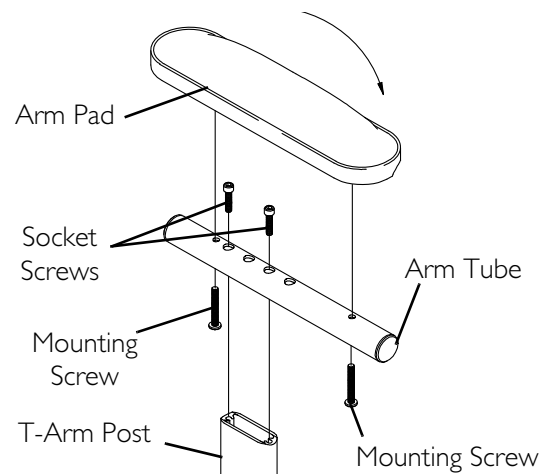

FIGURE 5.6 Adjusting T-Arm Depth

Adjusting T-Arm Sockets

NOTE: For this procedure, refer to FIGURE 5.7.

NOTE: Perform this procedure if the T-Arm is too loose in the socket or does not easily slide UP and DOWN in the socket.

1. Remove the rear wheels from the wheelchair, if necessary. Refer to [Installing/Removing Rear Wheels](#) on page 58.
2. Loosen, but DO NOT remove the four hex screws and washers that secure T-Arm socket to T-Arm clamp.

NOTE: The T-Arm socket will disassemble if the four hex screws and washers are removed.

3. Slide the T-Arm into the T-Arm socket until the locking lever is in the slot in the T-Arm socket and an audible “click” is heard.
4. Squeeze the T-Arm socket and the T-Arm clamp together until the socket is flush with the T-Arm.
5. While holding the T-Arm socket and the T-Arm clamp together, tighten the four hex screws and washers. Tighten securely.
6. Press IN on the locking lever and lift the T-Arm straight UP and out of the T-Arm socket.
7. Repeat STEPS 3-6, if necessary until the T-Arm slides in the T-Arm socket as desired.
8. If necessary, install rear wheels. Refer to [Installing/Removing Rear Wheels](#) on page 58.

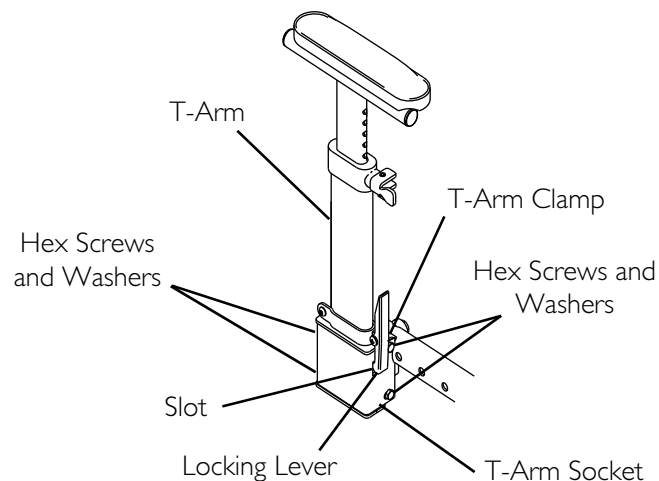

FIGURE 5.7 Adjusting T-Arm Sockets

Adjusting T-Arm Transfer Assists And/or Side Guards

NOTE: For this procedure, refer to FIGURE 5.8.

1. Remove the T-Arm from the wheelchair. Refer to Installing/Removing T-Arms on page 42.

2. Remove the two socket screws that secure the side guard to the bottom clamp.

NOTE: Adjusting the side guards will directly affect the position of the transfer assist.

3. Perform one of the following:

- Small Side Guards - Move the bottom clamp UP to one of two mounting positions in the side guard.
- Large Side Guards - Move the bottom clamp UP to one of three mounting positions in the side guard.

4. Secure the side guard to the bottom clamp with the two socket screws.

5. Install the T-Arm onto the wheelchair. Refer to Installing/Removing T-Arms on page 42.

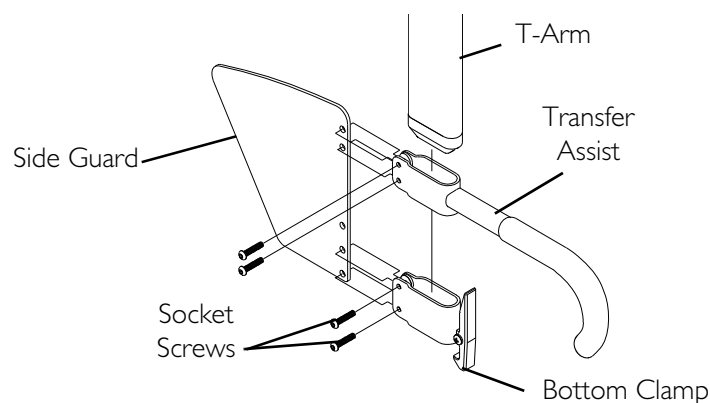

FIGURE 5.8 Adjusting T-Arm Transfer Assists And/or Side Guards

SECTION 6—BACK/SEAT

⚠ WARNING

After adjustments and before use make sure all attaching hardware is securely tightened.

Folding/Unfolding Back Assembly

NOTE: For this procedure, refer to FIGURE 6.1.

NOTE: When folding or unfolding the back, make sure the back release cord does not get caught in the release latches.

1. To unfold the back, push/pull the back towards rear of wheelchair until it locks in place.
-

⚠ WARNING

The back **MUST** be locked securely in place before using the wheelchair.

2. To fold the back, pick up on the back release cord and push the back towards the front of the wheelchair.

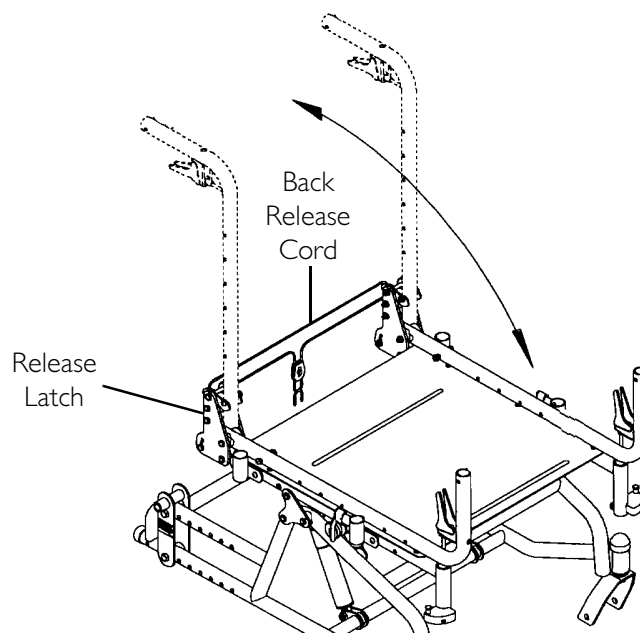

FIGURE 6.1 Folding/Unfolding Back Assembly

Installing and Removing a Seating System

⚠ WARNING

Invacare products are specifically designed and manufactured for use in conjunction with Invacare accessories. Accessories designed by other manufacturers have not been tested by Invacare and are not recommended for use with Invacare products.

1. Ensure that the seating system is compatible with this wheelchair.
2. Refer to the seating system Owner's Manual for installation and removal.

Installing Stroller Handle

NOTE: For this procedure, refer to FIGURE 6.2.

1. Remove the plug buttons from both back canes, if necessary.
2. Slide the stroller handle into the back canes.
3. Align the mounting holes of the stroller handle and the back canes.
4. Press the button on the quick-release pin and insert the quick-release pin through the back cane and stroller handle.
5. Release the button on the quick-release pin.
6. Pull on the stroller handle to make sure it is locked securely in place.

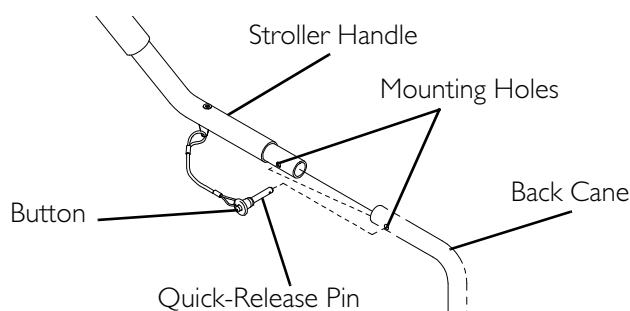

FIGURE 6.2 Installing Stroller Handle

Installing/Removing/Adjusting the Adjustable Angle Stroller Handles

NOTE: For this procedure, refer to FIGURE 6.3.

Installing

1. Remove plug buttons from both back canes.
2. Slide the adjustable height stroller handle into the back canes.
3. Align the mounting holes of the adjustable angle stroller handle and the back cane.
4. Secure adjustable angle stroller handle to the back canes with the two quick-release pins (Detail "A" of FIGURE 6.3).
5. If necessary, adjust the height.

Removing

1. Press and hold the buttons on the quick-release pins
2. Remove the adjustable angle stroller handle from the back cane.
3. Install plug buttons.

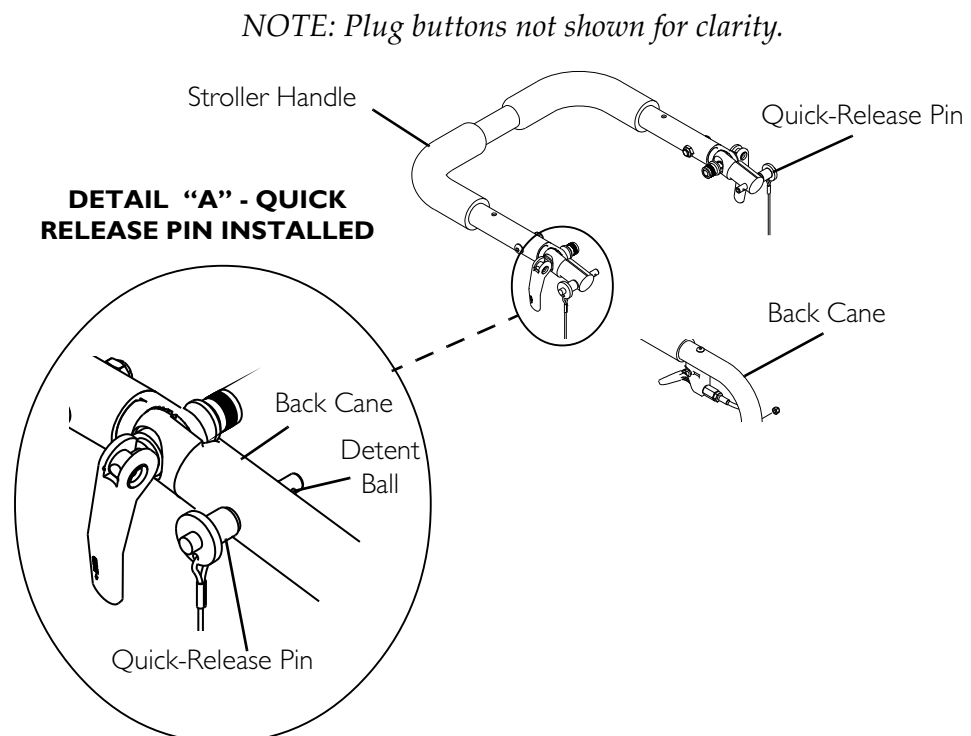

FIGURE 6.3 Installing/Removing/Adjusting the Adjustable Angle Stroller Handles

Adjusting/Replacing the Back Release Cord

⚠ WARNING

The back **MUST be locked securely in place before using the wheelchair.**

NOTE: For this procedure, refer to FIGURE 6.4.

NOTE: The back release cord may be adjusted to a tight or loose fit to meet the need of the user.

Adjusting the Back Release Cord

1. Press down on the white nylon lock to release the ends of the back release cord from the cord fastener.
2. Adjust the back release cord to the desired tension.

NOTE: Some slack in the back release cord may be necessary to clear the back upholstery.

3. Press up on the white nylon lock to lock the back release cord in place.

Replacing the Back Release Cord

1. Press down on the white nylon lock to release the ends of the back release cord from the cord fastener.
2. Feed one end of the back release cord through the cord fastener.
3. Remove the back release cord from wheelchair.
4. To install the new back release cord, reverse the above sections.

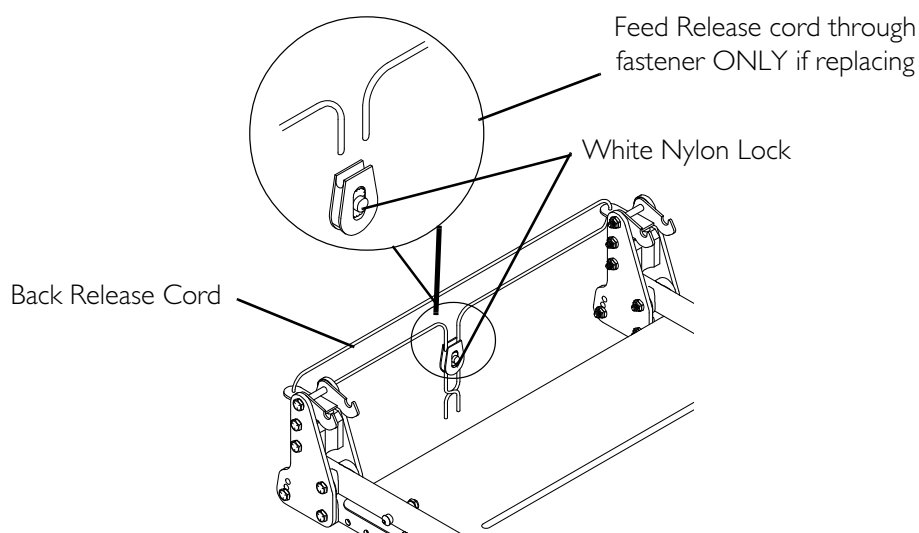

FIGURE 6.4 Adjusting/Replacing the Back Release Cord

Installing/Replacing Seat Positioning Straps

NOTE: For this procedure, refer to FIGURE 6.5.

Installing

1. Remove the hex screw and locknut that secures the back cane to the back plate.
2. Position the seat positioning strap against the back plate.
3. Install the hex screw through the seat positioning strap, covered spacers and back cane.
4. Securely tighten the seat positioning strap to the wheelchair with the locknut.
5. Repeat STEPS 1-4 for opposite side.

Replacing

1. Remove the hex screw, locknut and seat positioning strap from the back plate of the wheelchair frame.
2. Discard existing seat positioning strap.
3. Install the new seat positioning strap to the wheelchair. Refer to Installing/Replacing Seat Positioning Straps on page 51.

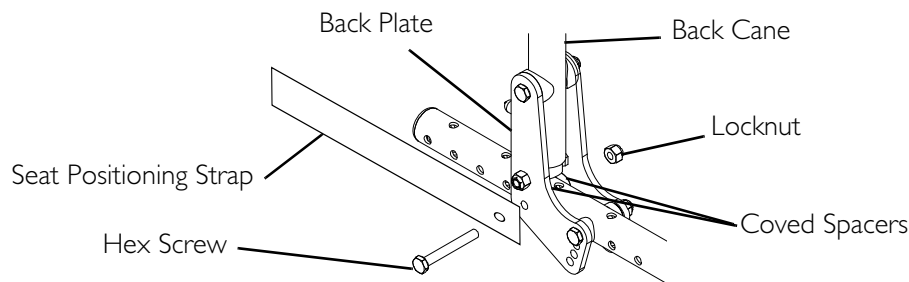

FIGURE 6.5 Installing/Replacing Seat Positioning Straps

Installing/Replacing Chest Positioning Straps

NOTE: For this procedure, refer to FIGURE 6.6.

Installing

1. Position the chest positioning strap to one of the holes on the back cane.

NOTE: The standard recommended position for the chest positioning strap is in the top hole of the back cane, but may be mounted according to the user's needs.

2. Secure the chest positioning strap to the back canes with the new/existing hex screw and locknut (FIGURE 6.6).
3. Repeat STEPS 1-2 for opposite side.

Replacing

1. Remove the hex screw that secures the chest positioning strap to the back cane.
2. Discard existing chest positioning strap.
3. Repeat STEPS 1-2 for opposite side, if necessary.
4. Install the new chest positioning strap. Refer to Installing/Replacing Chest Positioning Straps on page 52.

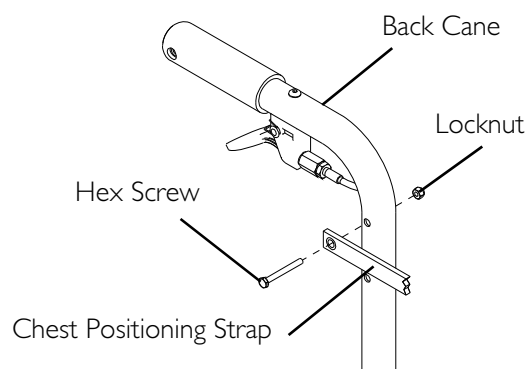

FIGURE 6.6 Installing/Replacing Chest Positioning Straps

SECTION 7—TILT

⚠ WARNING

After **ANY** adjustments, repair or service and **BEFORE** use, make sure all attaching hardware is tightened securely - otherwise injury or damage may occur.

Engaging Tilt-In-Space

⚠ WARNING

Both gas cylinders **MUST** be operational before using wheelchair. **DO NOT** operate tilt-in-space if only one of the gas cylinders is operational.

The Compass SPT wheelchair **MUST** be operated by an assistant when in any tilted position.

ALWAYS make sure that the wheelchair is stable before using the tilt-in-space. Wheels may have to be repositioned depending on the degree of tilt-in-space required. **ALWAYS** ensure stability before using maximum amount of tilt-in-space (45° for 15-20-inch seat depths and 35° for 20 and 21-inch seat depths). **TEST** wheelchair **BEFORE** it is occupied by the end user to ensure safety.

To maintain the stability of the wheelchair when moving the wheels to **ANY** position, the amount of tilt **MUST** be limited by adjusting limit stops on the gas cylinders to prevent wheelchair from tipping onto anti-tippers.

DO NOT self propel wheelchair while in the tilted position.

ALWAYS engage both wheel locks while using the tilt-in-space.

NOTE: For this procedure, refer to FIGURE 7.1 on page 54.

1. Place the wheelchair on a level surface.
 2. Engage both wheel locks.
 3. Inform the occupant of the wheelchair that the wheelchair is about to be tilted and remind them to lean back.
-

⚠ WARNING

ALWAYS verify the user's hand position prior to activating the tilt-in-space feature. **Failure to observe this warning can result in serious injury.**

4. Stand behind the wheelchair and grasp both back canes firmly.
 5. Pull up on the trigger release levers to release the gas cylinders.
 6. Slowly, push down on the back canes while pulling up on the trigger release levers in a continuous motion.
-

7. When the seat reaches the desired angle, slow let go of the trigger release levers.
8. To lower the seat parallel with the floor, reverse the above sections.

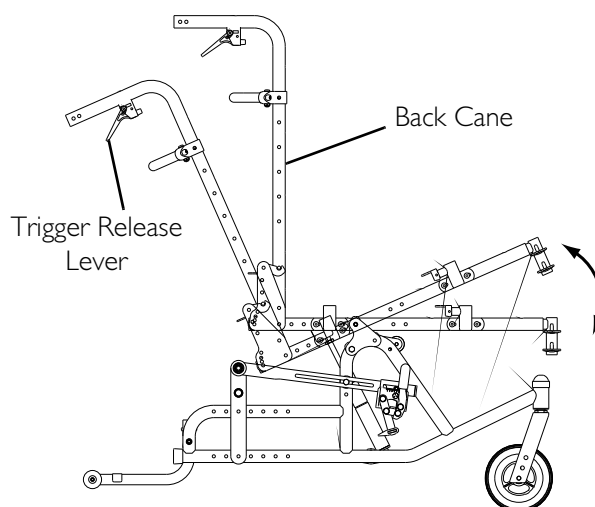

FIGURE 7.1 Engaging Tilt-In-Space

Adjusting Trigger Release Cables

NOTE: For this procedure, refer to FIGURE 7.2 on page 56.

14 to 20-Inch Wide Wheelchairs

⚠ WARNING

DO NOT adjust the trigger release cables while the cables are coiled up. The adjustment will be too tight when the cable is straightened and the gas cylinder will not lock and hold its position, possibly causing injury.

1. To adjust the left gas cylinder, squeeze the trigger release lever of the right cable assembly and try to tilt the wheelchair.

NOTE: The wheelchair should not tilt.

2. If the left side of the wheelchair tilts without squeezing the trigger release lever of the left cable assembly, perform the following steps:
 - A. Loosen the cable locking nut that secures the cable adjusting nut in place.
 - B. Turn cable adjusting nut one of two ways:

NOTE: If the cable is too loose, the tilt mechanism will not work.

⚠ WARNING

DO NOT over tighten the cable adjusting nut on the cable. Over tightening the cable adjusting nut on the cable **WILL** unlock the tilt mechanism, possibly causing injury.

- To Tighten - Turn the cable adjusting nut clockwise. DO NOT overtighten the cable adjusting nut (FIGURE 7.2).
 - To Loosen - Turn the cable adjusting nut counterclockwise (FIGURE 7.2).
- C. While holding the cable adjusting nut in place, tighten the cable locking nut against the cable adjusting nut.
 - D. Repeat STEP 1.
 - E. Repeat STEP 2 until the left side of the wheelchair does not tilt.
3. To adjust the right gas cylinder, repeat STEPS 1 and 2 for the left trigger release lever.

21 to 22-Inch Wide Wheelchairs

⚠ WARNING

DO NOT adjust the trigger release cables while the cables are coiled up. The adjustment will be too tight when the cable is straightened and the gas cylinder will not lock and hold its position, possibly causing injury.

1. To adjust the left gas cylinder, squeeze the trigger release lever of the left recliner cable assembly and try to tilt the wheelchair. The wheelchair should not tilt.
2. If the left side of the wheelchair tilts without squeezing the trigger release lever of the right cable assembly, perform the following steps:
 - A. Loosen the cable locking nut that secures the cable adjusting nut in place.
 - B. Turn cable adjusting nut one of two ways:

NOTE: If the cable is too loose, the gas cylinders will not work.

⚠ WARNING

DO NOT over tighten the adjusting nut on the cable. Over tightening the adjusting nut on the cable WILL actuate the gas cylinder, possibly causing injury.

- Clockwise - Turning the cable adjusting nut clockwise will tighten the cable. DO NOT overtighten the cable adjusting nut. Turn the cable adjusting nut clockwise until actuator looks like Detail "A" of FIGURE 7.2.
 - Counterclockwise - Turning the cable adjusting nut counterclockwise will loosen the cable. Turn the cable adjusting nut counterclockwise until actuator looks like Detail "A" of FIGURE 7.2.
- C. While holding the cable adjusting nut in place, tighten the cable locking nut against the cable adjusting nut.
 - D. Repeat STEP 1.
 - E. Repeat STEP 2 until the left side of the wheelchair does not tilt.
3. To adjust the right gas cylinder, repeat STEPS 1 and 2 for the right trigger release lever.

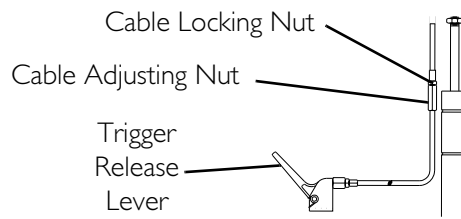

DETAIL "A"

Actuator Centered

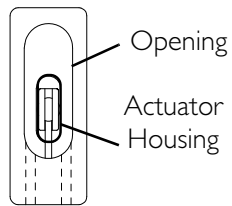

Actuator Too Low

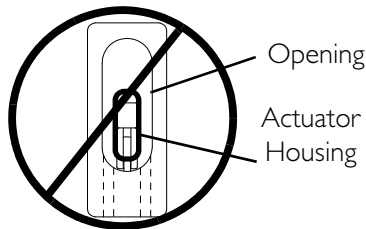

Actuator Too High

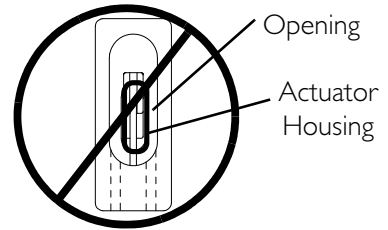

FIGURE 7.2 Adjusting Trigger Release Cables

SECTION 8—WHEELS

⚠ WARNING

After adjustments and before use make sure all attaching hardware is securely tightened.

Installing/Replacing Six or Eight-inch Caster/Fork

NOTE: For this procedure, refer to FIGURE 8.1.

Installing Caster/Fork

1. Remove the casters from the accessory carton.
2. Unscrew the locknut from the stem of the wheel/fork assembly.
3. Push the stem up through the caster head tube.
4. Install large plastic washer and secure with locknut.
5. To properly tighten caster journal system and guard against flutter, perform the following check:
 - A. Tip back of wheelchair to floor.
 - B. Pivot both forks and casters to top of their arc simultaneously.
 - C. Let casters drop to bottom of arc (wheels should swing once to one-side, then immediately rest in a straight downward position).
 - D. Adjust locknuts according to freedom of caster swing.
 - E. Snap black dust covers over the locknut and stem.
6. Test wheelchair for maneuverability.
7. Readjust locknuts if necessary and repeat STEPS 5 and 6 until correct.

Replacing Caster/Fork

1. Remove the black dust cover.
2. Remove locknut and plastic washer.
3. Drop the front caster/fork assembly out of the caster head tube.
4. Slide in the new six or eight-inch caster/fork assembly.
5. Reassemble by reversing STEPS 1-3.
6. Tighten caster journal system to guard against caster flutter. Refer to [Replacing Caster/Fork](#) on page 57.

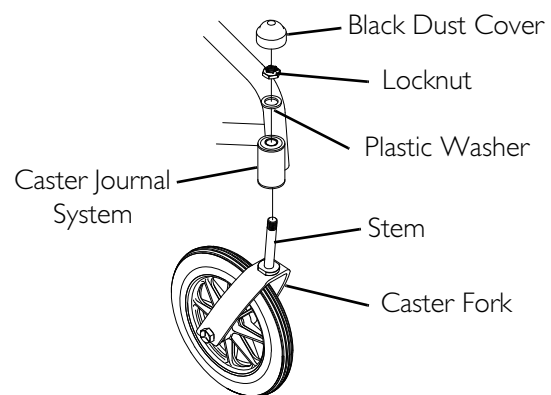

FIGURE 8.1 Installing/Replacing Six or Eight-inch Caster/Fork

Replacing/Repairing Caster Tire/Tube

⚠ WARNING

Replacement of caster tire or tube **MUST** be performed by a qualified technician.

CAUTION

As with any vehicle, the wheels and tires should be checked periodically for cracks and wear, and should be replaced.

Installing/Removing Rear Wheels

Quick-Release

NOTE: For this procedure, refer to FIGURE 8.2.

NOTE: To remove rear wheels, reverse this procedure.

1. Push in the detent pin of the quick-release axle and insert the quick-release axle through the center of the rear wheel.
2. Push in the tip of the quick-release axle again and insert the axle (with wheel) into the axle mounting plate on the side of the wheelchair frame until the assembly locks in place.

⚠ WARNING

Make sure detent pin and locking pins of the quick-release axles are fully released BEFORE operating the wheelchair.

The locking pins MUST be protruding past the inside of the axle mounting plate for a positive lock.

Keep locking pins clean.

3. Ensure quick release axle locking pins are properly engaged and secure in the axle mounting plate by pulling the rear wheel away from the wheelchair frame. If the locking pins **DO NOT** engage or there is too much movement of the rear wheel assembly in a back and forth position refer to [Adjusting the Quick-Release Axle](#) on page 59.
4. Repeat STEPS 1-3 for other rear wheel assembly.
5. Adjust the wheel locks. Refer to [Wheel Lock Adjustment](#) on page 61.

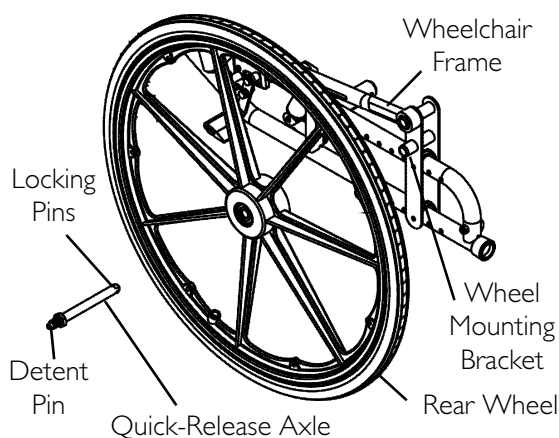

FIGURE 8.2 Installing/Removing Rear Wheels - Quick-Release

Permanent Axle

NOTE: For this procedure, refer to FIGURE 8.3.

NOTE: To remove rear wheels, reverse this procedure.

1. Remove the permanent axles from the packaged container.
2. Install permanent axle through the rear wheel and axle plate.
3. Securely tighten the wheel to the wheelchair frame with locknut.

NOTE: Only 22-inch rear wheel is shown. All other wheels will install/remove in the same manner.

4. Repeat STEPS 2-3 for other rear wheel assembly.
5. Adjust the wheel locks. Refer to [Adjusting the Quick-Release Axle](#) on page 59.

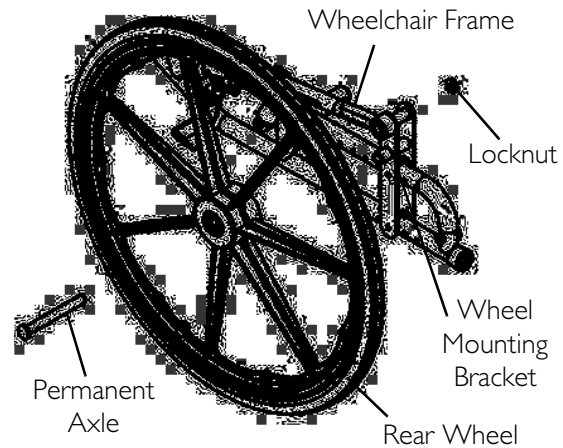

FIGURE 8.3 Installing/Removing Rear Wheels - Quick-Release

Adjusting the Quick-Release Axle

NOTE: For this procedure, refer to FIGURE 8.4.

1. Remove wheel and quick-release axle from the wheelchair.
2. Depress detent pin in the quick-release axle and slide axle through the wheel hub.
3. Increase or decrease end play in the quick-release axle by adjusting the locknut on the end of the quick-release axle.
4. Reinstall wheel onto the wheelchair.

⚠ WARNING

Make sure detent pin and locking pins of the quick-release axle are fully released BEFORE operating the wheelchair.

Keep locking pins clean.

5. Release detent pin ensuring that the locking pins are fully released.
6. Repeat the above sections until the quick-release axle locks properly.

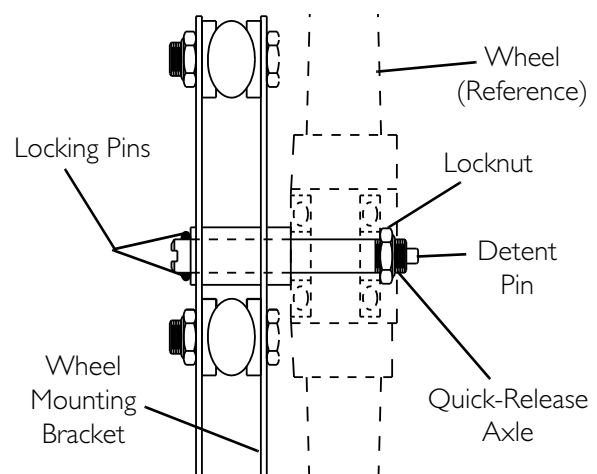

FIGURE 8.4 Adjusting the Quick-Release Axle

Replacing Wheel Handrim

NOTE: For this procedure, refer to FIGURE 8.5.

1. Remove the wheel from the wheelchair. Refer to Installing/Removing Rear Wheels on page 58.
2. Remove the button screws that secure the existing handrim to the wheel.
3. Remove the existing handrim.
4. Install the new handrim by reversing STEPS 2-3.

⚠ WARNING

Make sure detent pin and locking pins of the quick-release axles are fully released BEFORE operating the wheelchair.

5. Reinstall wheel to the wheelchair. Refer to Installing/Removing Rear Wheels on page 58.
6. Repeat STEPS 1-5 for the opposite wheel if necessary.

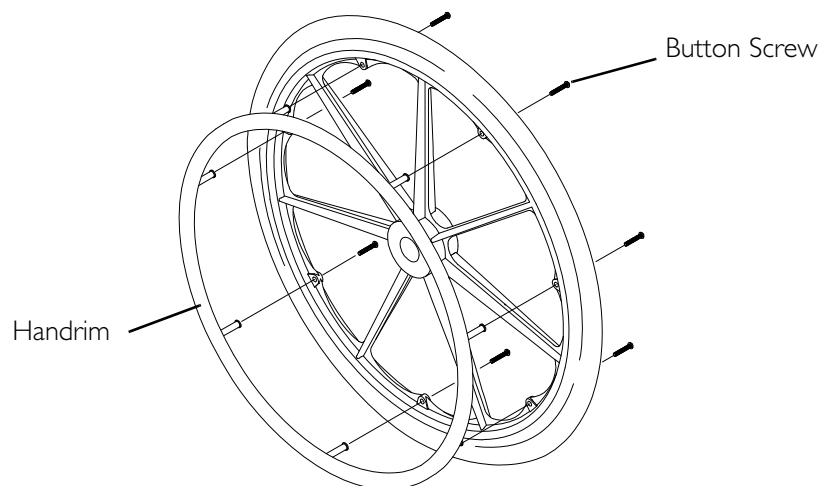

FIGURE 8.5 Replacing Wheel Handrim

Replacing/Repairing Wheel Tire/Tube

⚠ WARNING

Replacement of wheel tire or tube MUST be performed by a qualified technician.

SECTION 9—WHEEL LOCKS AND ANTI-TIPPERS

⚠ WARNING

After adjustments and before use make sure all attaching hardware is securely tightened.

Wheel Lock Adjustment

NOTE: For this procedure, refer to FIGURE 9.1.

NOTE: Before adjusting the wheel lock assemblies, ensure that the tires are inflated to the recommended p.s.i on the side wall of the tire.

1. Loosen the two socket screws that secure the wheel lock assembly to the wheelchair frame.

NOTE: Any wheel lock adjustment should embed the wheel lock shoe at least 3/16-inch into the tire when engaged.

2. Adjust the position of wheel lock until the 3/16-inch measurement is obtained for correct wheel lock adjustment.
3. Securely tighten the two socket screws.
4. Engage the wheel lock and push against the wheelchair and determine if the wheel lock engages the wheel lock shoe enough to hold the wheelchair.
5. Repeat the above sections until the wheel lock holds the wheelchair.
6. Repeat section for opposite wheel lock.

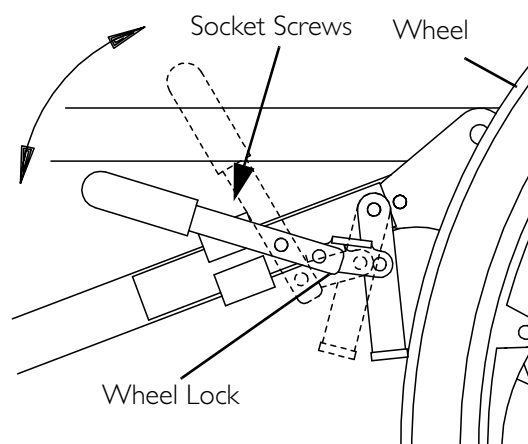

NOTE: Wheel lock shoe should be embedded into rear wheel tire at least 3/16-inch.

FIGURE 9.1 Wheel Lock Adjustment

Installing/Adjusting Anti-Tippers

NOTE: For this procedure, refer to FIGURE 9.2.

NOTE: A 1½ to 2-inch clearance between the bottom of the anti-tipper wheels and the floor MUST be maintained at all times.

Installing Anti-Tippers

1. Remove the anti-tippers from the accessory carton.

⚠ WARNING

Anti-tippers MUST be fully engaged and spring buttons fully protruding out of adjustment holes.

2. Press the release button in and insert the anti-tippers into the anti-tipper mounting bracket on the wheelchair frame until the spring button protrudes from the top adjustment hole.
3. Ensure the anti-tipper wheels are 1½ to 2-inches from the ground/floor.
4. Adjust the anti-tipper if necessary. Refer to [Adjusting Anti-Tippers](#) on page 62.

Adjusting Anti-Tippers

NOTE: A 1½ to 2-inch clearance between the bottom of the anti-tipper wheels and the floor MUST be maintained at all times.

1. Press the release button in and adjust the anti-tipper until the spring button protrudes from the other adjustment hole in the anti-tipper mounting bracket.

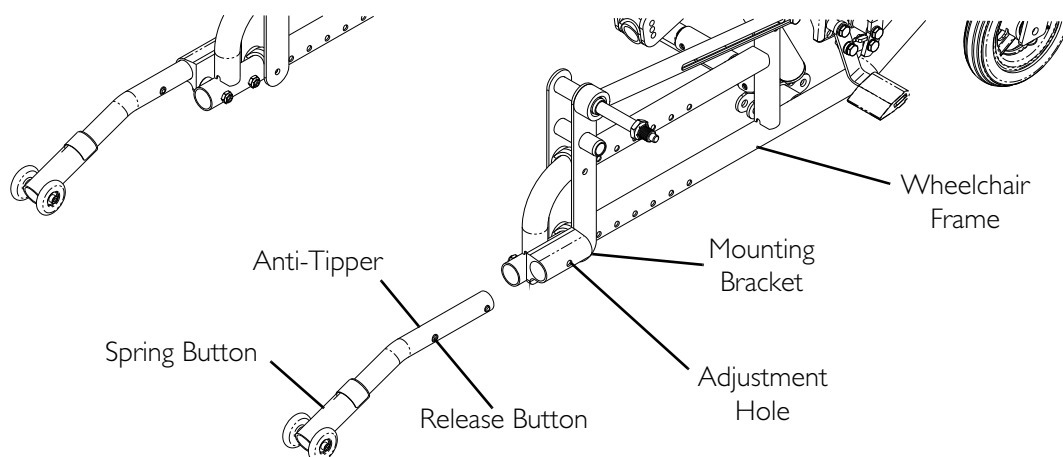

FIGURE 9.2 Installing/Adjusting Anti-Tippers

LIMITED WARRANTY

PLEASE NOTE: THE WARRANTY BELOW HAS BEEN DRAFTED TO COMPLY WITH FEDERAL LAW APPLICABLE TO PRODUCTS MANUFACTURED AFTER JULY 4, 1975.

This warranty is extended only to the original purchaser/user of our products.

This warranty gives you specific legal rights and you may also have other legal rights which vary from state to state.

Invacare warrants its product, except for the seat cushion (which is not warranted), to be free from defects in materials and workmanship for a period of one (1) year from date of purchase. The side frames and crossmembers are warranted for the lifetime of the original purchaser/user. If within such warranty period any such product shall be proven to be defective, such product shall be repaired or replaced, at Invacare's option. This warranty does not include any labor or shipping charges incurred in replacement part installation or repair of any such product. Invacare's sole obligation and your exclusive remedy under this warranty shall be limited to such repair and/or replacement.

For warranty service, please contact the dealer from whom you purchased your Invacare product. In the event you do not receive satisfactory warranty service, please write directly to Invacare at the address at the bottom of the back cover. Provide dealer's name, address, date of purchase, indicate nature of the defect and, if the product is serialized, indicate the serial number. Do not return products to our factory without our prior consent.

LIMITATIONS AND EXCLUSIONS: THE FOREGOING WARRANTY SHALL NOT APPLY TO SERIAL NUMBERED PRODUCTS IF THE SERIAL NUMBER HAS BEEN REMOVED OR DEFACED, PRODUCTS SUBJECTED TO NEGLIGENCE, ACCIDENT, IMPROPER OPERATION, MAINTENANCE OR STORAGE, PRODUCTS MODIFIED WITHOUT INVACARE'S EXPRESS WRITTEN CONSENT INCLUDING, BUT NOT LIMITED TO, MODIFICATION THROUGH THE USE OF UNAUTHORIZED PARTS OR ATTACHMENTS; PRODUCTS DAMAGED BY REASON OF REPAIRS MADE TO ANY COMPONENT WITHOUT THE SPECIFIC CONSENT OF INVACARE, OR TO A PRODUCT DAMAGED BY CIRCUMSTANCES BEYOND INVACARE'S CONTROL, AND SUCH EVALUATION WILL BE SOLELY DETERMINED BY INVACARE. THE WARRANTY SHALL NOT APPLY TO PROBLEMS ARISING FROM NORMAL WEAR OR FAILURE TO ADHERE TO THESE INSTRUCTIONS.

THE FOREGOING EXPRESS WARRANTY IS EXCLUSIVE AND IN LIEU OF ANY OTHER WARRANTIES WHATSOEVER, WHETHER EXPRESS OR IMPLIED, INCLUDING THE IMPLIED WARRANTIES OF MERCHANTABILITY AND FITNESS FOR A PARTICULAR PURPOSE, AND THE SOLE REMEDY FOR VIOLATIONS OF ANY WARRANTY WHATSOEVER, SHALL BE LIMITED TO REPAIR OR REPLACEMENT OF THE DEFECTIVE PRODUCT PURSUANT TO THE TERMS CONTAINED HEREIN. THE APPLICATION OF ANY IMPLIED WARRANTY WHATSOEVER SHALL NOT EXTEND BEYOND THE DURATION OF THE EXPRESS WARRANTY PROVIDED HEREIN. THE MANUFACTURER SHALL NOT BE LIABLE FOR ANY CONSEQUENTIAL OR INCIDENTAL DAMAGES WHATSOEVER.

THIS WARRANTY SHALL BE EXTENDED TO COMPLY WITH STATE/PROVINCIAL LAWS AND REQUIREMENTS.



Yes, you can.

Invacare Corporation www.invacare.com

USA
One Invacare Way
Elyria, Ohio USA
44036-2125
800-333-6900

Canada
570 Matheson Blvd E Unit 8
Mississauga Ontario
L4Z 4G4 Canada
800-668-5324

Invacare, Yes, you can., and The Medallion Design are registered trademarks of Invacare Corporation. Compass and SPT are trademarks of Invacare Corporation.

3-in-1 Oil is a registered trademark of American Home Products Corporation. WD-40 is a registered trademark of the WD-40 Company.

Teflon is a registered trademark of E.I. Du Pont De Nemours and Company.

© 2006 Invacare Corporation

Part No 1122134

Rev D - 6/14/06