

Everest & Jennings®
A Graham-Field Brand

Everest™

with Captain Seat POWER WHEELCHAIR



OWNER'S MANUAL

GF0600050RevE06
©GF Health Products, Inc.
August 2006

**IMPORTANT: READ THIS MANUAL BEFORE
OPERATING YOUR WHEELCHAIR**

CONTENTS

I INTRODUCTION	3
II IMPORTANT SAFETY PRECAUTIONS	4
III HANDLING TIPS	9
IV GETTING STARTED.....	11
V OPERATING INSTRUCTIONS	14
VI ADJUSTMENTS	15
VII BATTERIES	24
VIII MAINTENANCE	32
IX TROUBLESHOOTING.....	38
X LIMITED WARRANTY.....	45
XI INDEX.....	47

READ THIS MANUAL BEFORE OPERATING YOUR WHEELCHAIR

I INTRODUCTION

Important safety, operating, and maintenance instructions that warrant your attention are included in this owner's manual. Read the entire manual carefully before operating your new wheelchair, and refer to it as often as necessary to help maintain good performance standards. If you do not understand the warnings and instructions provided herein, contact your healthcare professional, Graham-Field Health Products dealer or technical representative before proceeding with the use of this product; otherwise personal injury or damage to your wheelchair could result.

Consult your healthcare professional and qualified Graham-Field Health Products dealer for assistance in developing and learning safe and effective techniques for performing your daily activities according to your individual physical abilities and needs, and to make certain that your wheelchair is properly prescribed and adjusted for your use. All procedures involved should be practiced with an attendant until you are thoroughly familiar with them.

The safety precautions in this manual are general warnings intended to be used only as basic guidelines. You may find it necessary to develop your own methods for safely solving frequently encountered challenges. Again, consult your professional healthcare advisors for their recommendations about safety methods, and never hesitate to ask for their assistance.

Your new wheelchair should receive frequent, regularly scheduled maintenance, including an inspection of the mechanical parts, to ensure proper operation. Some suggested inspection procedures, troubleshooting procedures, and adjustment procedures are included in this manual. When it comes to service and repair, remember that your Graham-Field Health Products dealer knows your wheelchair best.

All information and specifications in this manual are current at the time of printing. However, because it is Graham-Field Health Products policy to continually improve the quality and reliability of all our products, we must reserve the right to make changes at any time without notice.

Thank you for choosing an Everest & Jennings® product. We at Graham-Field Health Products wish to assure you of our continuing commitment to provide innovation and quality in our products. The Everest with Captain Seat is available with either front wheel drive or rear wheel drive. It is a highly maneuverable power wheelchair, suitable for frequent users who require a power wheelchair with tight turning capability. The Everest with Captain Seat is intended for indoor and/or outdoor use, and is ideal for tight spaces and over firm surfaces. Its maximum weight capacity is 300 pounds (136 kg).

The person performing adjustments on the Everest with Captain Seat has the responsibility of making certain that the user can safely operate the wheelchair with the adjustments selected. This person must evaluate the user's ability, weight, physical condition, the environment in which the wheelchair will be used, and the terrain over which the wheelchair will travel.

Please note the following special statements, used throughout this manual, and their significance:

Note: Special information set off from the text.

▲ **Caution:** Damage to equipment is possible.

⚠ **WARNING:** Personal injury could occur.

II IMPORTANT SAFETY PRECAUTIONS

Important safety precautions: Always follow these safety precautions when using your wheelchair. Failure to do so could result in personal injury to you or others or damage to your wheelchair.

Safety requires the constant attention of the wheelchair user and the attendant. It is extremely important to learn and always use safe methods of performing basic daily activities. Always consult healthcare professionals to determine those methods most suitable for your individual abilities.

Protect yourself and your wheelchair by having your Everest with Captain Seat serviced regularly. Whenever any part of your Everest with Captain Seat is not functioning properly, contact your Graham-Field Health Products dealer immediately, as a hazardous situation could result, causing personal injury or damage to your wheelchair. **ONLY EXCELLENT CONDITION IS ACCEPTABLE WHERE SAFETY IS CONCERNED.** Periodic inspection, adjustment, and replacement of worn parts will provide many years of superb performance.

WARNINGS

- ⚠ WARNING: The Everest with Captain Seat maximum weight capacity is 300 pounds (136 kg).**
- ⚠ WARNING: The wheelchair user must be capable of driving a power wheelchair safely.**
- ⚠ WARNING: Do not operate this wheelchair on streets or roadways.**
- ⚠ WARNING: Use the positioning strap at all times to prevent injury.**
- ⚠ WARNING: Do not operate this wheelchair on hilly or rough terrain, sand, wet or icy surfaces, or surfaces with impaired traction.**
- ⚠ WARNING: Do not attempt any incline or decline greater than six degrees (10% grade, or one foot of rise or fall per ten feet of ramp length).**
- ⚠ WARNING: Exercise caution if turning wheelchair while going downhill.**
- ⚠ WARNING: This wheelchair does not offer seating or occupant restraint equivalent to the seat provided in a motor vehicle! To increase your safety while traveling in a motor vehicle, always transfer to the vehicle seat and use the restraint provided by the vehicle manufacturer.**
- ⚠ WARNING: Do not tie down or attach anything to the wheels. This could cause tipping and could result in personal injury or damage to the wheelchair.**

-
- ⚠ WARNING:** Ensure that the lowest point on the footplates clears the ground safely during ascent or descent.

 - ⚠ WARNING:** Do not enter or exit the wheelchair without first turning wheelchair power off, and ensuring that the drive engagement levers are engaged, to prevent wheelchair movement.

 - ⚠ WARNING:** Disengaging the drive engagement levers will also disengage the electro-mechanical park brakes and allow the wheelchair to roll.

 - ⚠ WARNING:** Ensure that no water, moisture, or other liquid enters the controller or hand control.

 - ⚠ WARNING:** The controller should be adjusted only by a qualified therapist or technician. This person must evaluate the user's ability, weight, physical condition, the environment in which the wheelchair will be used, and the terrain over which the wheelchair will travel. The controller's range of adjustment and versatility is provided so that the requirements of many different abilities may be met, and the person setting the driving characteristics has the responsibility of making certain that the user can safely operate the wheelchair at the speed and rates selected.

 - ⚠ WARNING:** When adjusting with the programmer, start with a slow (low number) drive profile. Increase only if the user has the ability to control the wheelchair safely.

 - ⚠ WARNING:** When adjusting with the programmer, use caution when changing the parameters to a setting different than that provided by the standard drive profiles.

 - ⚠ WARNING:** When adjusting with the programmer, do not set reverse speed faster than forward speed.

 - ⚠ WARNING:** Ensure that wheelchair power is off before connecting or disconnecting the programmer.

 - ⚠ WARNING:** Do not disconnect the wheelchair batteries while the programmer is connected to the controller.

 - ⚠ WARNING:** Do not connect accessories to the batteries; it will decrease driving range and shorten battery life. Do not connect ANYTHING to only one battery; this will cause premature battery failure.

-
- ⚠ WARNING:** Never connect a respirator or other life-support device to the wheelchair batteries, since it will shorten the battery operating time. This could cause an unanticipated failure of both the wheelchair and the life-support equipment.
- ⚠ WARNING:** Do not stand or step on the footplates while transferring to or from your wheelchair. This could cause the wheelchair to tip or may cause personal injury or damage to your wheelchair.
- ⚠ WARNING:** Always ensure that the wheelchair is on a stable, level surface, engage the drive engagement levers, and turn wheelchair power off before transferring, using a wheelchair lift, or using an elevator.
- ⚠ WARNING:** Do not attempt to reach objects if you are required to move forward in the seat. Do not attempt to retrieve objects from the floor if you must reach down between your knees. Do not shift your weight in the direction that you are reaching and/or bending; this could cause the wheelchair to tip.
- ⚠ WARNING:** Unauthorized modification or the use of non-Everest & Jennings® replacement parts could change the structure of the wheelchair, void the warranty, and create a hazardous condition resulting in serious personal injury.
- ⚠ WARNING:** Do not lean on this wheelchair, use it to support yourself (except while sitting in it), or use it as a walker—these are practices which could result in loss of balance and personal injury.
- ⚠ WARNING:** Do not tow any loads or "piggyback" passengers or heavy packages.
- ⚠ WARNING:** Keep all cables away from the moving parts of the wheelchair.
- ⚠ WARNING:** Do not use your wheelchair on escalators.
- ⚠ WARNING:** As a safety feature, this wheelchair is equipped with fail-safe electromechanical park brakes. Any interruption in the power supply will cause these brakes to immediately engage and stop the wheelchair. If the user is not properly positioned, an unanticipated stop could pitch the user forward and out of the wheelchair. Use the positioning strap at all times to prevent injury.
- ⚠ GF Health Products, Inc. specifically disclaims responsibility for any personal injury or property damage which may occur during any use which does not comply with federal, state, or local laws or ordinances.**

ELECTROMAGNETIC INTERFERENCE (EMI) FROM RADIO WAVE SOURCES

It is very important that you read this information regarding the possible effects of electromagnetic interference on your Everest & Jennings® Everest with Captain Seat power wheelchair.

Powered wheelchairs may be susceptible to electromagnetic interference (EMI), which is interfering electromagnetic (EM) energy emitted from sources such as radio stations, TV stations, amateur radio (HAM) transmitters, two-way radios, and cellular telephones. The interference (from radio wave sources) can cause the powered wheelchair to release its brakes, move by itself, or move in unintended directions. It can also permanently damage the powered wheelchair's control system. The intensity of the interfering EM energy can be measured in volts per meter (V/m). Each powered wheelchair can resist EMI up to a certain intensity. This is called its "immunity level". The higher the immunity level, the greater the protection. At this time, current technology is capable of achieving at least a 20 V/m immunity level, which would provide useful protection from the more common sources of radiated EMI.

This powered wheelchair model has an immunity level of 20 V/m.

Be aware that using different components, adding accessories, or modifying the powered wheelchair may change the immunity level.

There are a number of sources of relatively intense electromagnetic fields in the everyday environment. Some of these sources are obvious and easy to avoid. Others are not apparent and exposure is unavoidable. However, we believe that by following the warnings that follow, your risk to EMI exposure will be minimized.

The sources of radiated EMI can be broadly classified into three types:

- 1) Hand-held portable transceivers (transmitters-receivers) with the antenna mounted directly on the transmitting unit. Examples include: citizens band (CB) radios, "walkie talkies", security, fire, and police transceivers, cellular telephones, and other personal communication devices.

Note: Some cellular telephones and similar devices transmit signals while they are on, even when not being used;

- 2) Medium-range mobile transceivers, such as those used in police cars, fire trucks, ambulances, and taxis. These usually have the antenna mounted on the outside of the vehicle; and
- 3) Long-range transmitters and transceivers, such as commercial broadcast transmitters (radio and TV broadcast antenna towers) and amateur (HAM) radios.

Note: Other types of hand-held devices, such as cordless telephones, laptop computers, AM/FM radios, TV sets, CD players, and cassette players, and small appliances, such as electric shavers and hair dryers, so far as we know, are not likely to cause EMI problems with your powered wheelchair.

POWERED WHEELCHAIR ELECTROMAGNETIC INTERFERENCE (EMI)

Because EM energy rapidly becomes more intense as one moves closer to the transmitting antenna (source), the EM fields from hand-held radio wave sources (transceivers) are of special concern. It is possible to unintentionally bring high levels of EM energy very close to the powered wheelchair's control system while using these devices. This can affect powered wheelchair movement and braking. Therefore, the warnings that follow are recommended to prevent possible interference with the control system of the powered wheelchair.

EMI WARNINGS

Electromagnetic interference (EMI) from sources such as radio and TV stations, amateur radio (HAM) transmitters, two-way radios, and cellular telephones can affect powered wheelchairs. Following the warnings listed below should reduce the chance of unintended brake release or powered wheelchair movement which could result in serious injury.

⚠ WARNING: Do not operate hand-held transceivers (transmitters-receivers), such as citizens band (CB) radios, or turn on personal communication devices, such as cellular telephones, while the powered wheelchair is turned on.

⚠ WARNING: Be aware of nearby transmitters, such as radio or TV stations, and try to avoid coming close to them.

⚠ WARNING: If unintended movement or brake release occurs, turn the powered wheelchair off as soon as it is safe.

⚠ WARNING: Be aware that adding accessories or components, or modifying the powered wheelchair, may make it more susceptible to EMI (Note: There is no easy way to evaluate their effect on the overall immunity of the powered wheelchair).

⚠ WARNING: Report all incidence of unintended movement or brake release to Graham-Field Health Products, and note whether there is a source of EMI nearby.

IMPORTANT INFORMATION

- 1) 20 volts per meter (V/m) is a generally achievable and useful immunity level against EMI (as of May 1994) (the higher the level, the greater the protection);
- 2) This powered wheelchair model has an immunity level of 20 V/m.

Be aware that using different components, adding accessories, or modifying the powered wheelchair may change the immunity level.

III HANDLING TIPS

The Everest & Jennings® Everest with Captain Seat has been designed and engineered to perform as a stable and well balanced unit when used as intended, but it is possible to tip the Everest with Captain Seat over if used improperly. We urge you to learn the characteristics of your wheelchair. It is most important to learn safe methods to perform the daily activities basic to your lifestyle. Consult healthcare professionals for assistance in developing the skills and proper techniques to perform all activities safely.

BALANCE

Proper balance is the key to maintaining the stability of your wheelchair. Reaching, bending, and transferring to or from a wheelchair will change the weight distribution and center of gravity of you and your wheelchair. When performing such activities, do so as instructed in the following paragraphs to avoid tipping the wheelchair.

TRANSFER ACTIVITIES

⚠ WARNING: Always ensure that wheelchair is on a stable, level surface, engage the drive engagement levers, and turn wheelchair power off before transfer.

⚠ WARNING: Do not step on the footplates during transfer; this could cause the wheelchair to tip. Fold the footplates up during transfer. There is a critical moment when there is little or no seat platform beneath you. Take every precaution to reduce this unsupported distance before you attempt transfer.

Transferring to or from a wheelchair is a very difficult maneuver. Exercise extreme care when transferring without the aid of either an attendant or a patient lift. Consult healthcare professionals for assistance in developing your individual technique. Make sure that the wheelchair is stabilized, and will not move or slide during the transfer. Take extra precaution to prevent tipping. Use good body mechanics to prevent personal injury.

REACHING / BENDING

Although it is not recommended, you may find it occasionally necessary to lean or reach from your wheelchair. Consult with healthcare professionals for assistance in developing your personal safe reaching or moving techniques suited to your ability and restrictions.

Forward or sideward

⚠ WARNING: Do not attempt to reach objects if you are required to move forward in the seat. Do not attempt to retrieve objects from the floor if you must reach down between your knees. Do not shift your weight in the direction that you are reaching and/or bending; this could cause the wheelchair to tip.

1. Maneuver the wheelchair as close as possible to the object you wish to reach.
2. Reach only as far as your arm will extend without changing your sitting position. If in doubt, reposition the wheelchair or ask for assistance.

Backward

1. Maneuver the wheelchair as close as possible to the object; the casters will limit how close you can get.
2. Reach only as far as your arm will extend without changing your sitting position. If in doubt, reposition the wheelchair or ask for assistance.

RAMPS AND INCLINES

- ⚠ WARNING: During descent, ensure that the lowest point on the footplates clears the ground safely.**
- ⚠ WARNING: Do not attempt any incline or decline of more than 6 degrees (10% grade, or one foot of rise or fall per ten feet of ramp length).**
- ⚠ WARNING: Avoid changing direction while descending a ramp or incline, as this could cause instability.**

Most people are capable of negotiating short inclines without assistance, depending upon upper body strength, endurance, and the degree of incline. Know your own capabilities and limitations in terms of strength and endurance before attempting to negotiate an incline or decline. Practice with an attendant or healthcare professional first before attempting any inclines, declines curbs or ramps. Always inspect the ramp for hazards such as holes, slippery or uneven surfaces, etc. before starting up or down. If you can not see the entire ramp, ask someone to inspect it for you.

Ascent

Lean the upper part of your body slightly forward as you ascend the incline. If it becomes necessary to stop on the incline, avoid any abrupt or sudden forward movement as you resume climbing, this could cause tipping.

Descent

Always face forward when going down, but do not lean forward; this could cause tipping. Lean slightly backward to increase stability.

It is critical to keep the wheelchair under control at all times. Descent should be made slowly and steadily, allowing the wheelchair's control system to maintain a safe speed. Upon stopping, electromechanical park brakes will engage to prevent the wheelchair from rolling.

CURBS AND STEPS

Curbs, steps and stairways are dangerous obstacles that confront the wheelchair user. When you encounter curbs, find a way around, or use the ramps now available in most locations. If you encounter steps and there is no ramp available, avoid the steps by utilizing the disabled designated elevators now required in most locations.

- ⚠ WARNING: Never attempt to negotiate steps, stairs or escalators in your Everest with Captain Seat.**

IV GETTING STARTED

The Everest with Captain Seat is designed to provide the highest degree of independence and mobility. It offers superior maneuverability and exceptionally tight turning capability. The theoretical range of the Everest with Captain Seat is approximately 10 miles (16 km) with a 220 pound (100 kg) user on a hard level surface with fully charged U1 sealed batteries, tested per ANSI/RESNA Specification WC04 Energy Consumption. Actual range will vary according to your weight, the amount of start/stop driving, ambient temperature, and the terrain on which you travel with your wheelchair. As you become acquainted with your wheelchair, its range and performance capabilities will become apparent. The Everest with Captain Seat, Rear Wheel Drive model, is illustrated below. Main features are identified.



POWER DRIVE SYSTEM

The Everest with Captain Seat power drive system consists of two independent drive wheels, a hand control, the controller, independent, direct drive right and left motors, and two twelve volt batteries that provide power.

The motors operate in both the forward and reverse direction. Motor speed and direction are controlled by the joystick. The joystick commands are interpreted and applied to the motors by the controller.

CONTROLLER

See picture at right. The controller is mounted below the seat. The controller contains the connectors to the rest of the wheelchair control system. The connectors used by Everest are labelled in the picture above - connectors not labelled in this picture are not used by this wheelchair's control system.

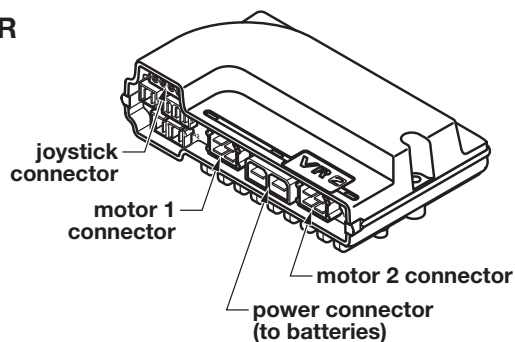

VR2 controller *

** VR2 is a trademark of PG Drives Technology, Inc.*

HAND CONTROL

See picture at right. The hand control is mounted at the front of either arm. The hand control contains the joystick, battery charger receptacle (also used for the optional programmer), mounting holes for the extension bracket, and those features found on the control panel, shown on the next page: the ON/OFF button, battery indicator, maximum speed/profile indicator, horn button, speed profile decrease button, and speed/profile increase button. Their descriptions follow.

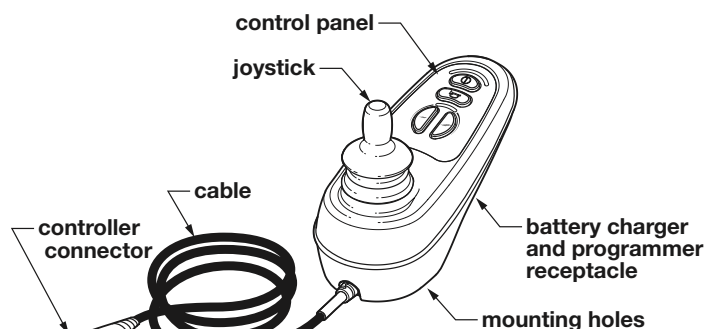

VR2 hand control

Joystick

The joystick controls the speed and direction of wheelchair travel. The further you move the joystick from the rest position, the faster your wheelchair will move. When the joystick is returned to the neutral (center) position or released, the control system will bring the wheelchair to a smooth stop. Upon stopping, electromechanical park brakes will engage to prevent the wheelchair from rolling.

Moving the joystick forward (away from the user) causes the wheelchair to move forward. Moving the joystick back (toward the user) causes the wheelchair to travel in reverse. When the joystick is moved right to 3 o'clock position, the wheelchair will turn to the right; when the joystick is moved left to 9 o'clock position, the wheelchair will turn to the left.

Battery charger receptacle (and optional programmer receptacle)

The receptacle for the battery charger (and optional programmer) is located on the underside of the controller, as shown above. Use only the battery charger supplied with the wheelchair.

Controller cable

The controller cable plugs into the controller.

Hand control panel features (see picture below right)

ON/OFF button

The ON/OFF button switches wheelchair power on and off. When wheelchair power is on, the battery indicator illuminates.

Battery indicator

The three-color (green, yellow and red) battery indicator illuminates when wheelchair power is on. The battery indicator shows the charge level of the batteries. As the batteries discharge, the lights go off from green to red, similarly to an automobile's gas gauge (all lights on = full). When the batteries are nearly discharged, only the red lights will illuminate. When one red light flashes slowly, charge batteries immediately. When you switch wheelchair power on, the battery indicator shows an estimate of the remaining battery charge (the reading will be more accurate about a minute after you start driving the wheelchair). The battery indicator also provides a diagnostics display when wheelchair control system problems occur. See **TROUBLESHOOTING** for a description of the battery indicator diagnostics.

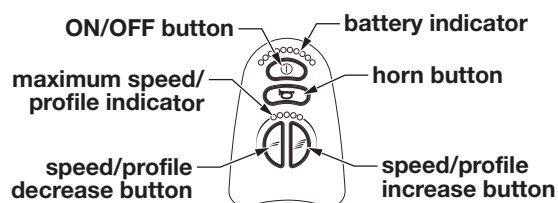

**VR2 hand control
control panel**

Maximum speed / profile indicator

This 5-segment display indicates the maximum speed setting or which drive profile is selected, if drive profiles have been programmed.

Horn button

This button operates the wheelchair's horn.

Speed / profile decrease button

This button decreases the maximum speed setting or selects a lower drive profile, if drive profiles have been programmed.

Speed profile increase button

This button increases the maximum speed setting or selects a higher drive profile, if drive profiles have been programmed.

BATTERIES

Please see Section VII, **BATTERIES**, which also describes the battery charger included with your Everest with Captain Seat. Charge the batteries fully before operating your wheelchair. For installation and charging information, refer to Section VII, **BATTERIES**.

CIRCUIT BREAKER

Your Everest with Captain Seat is equipped with a circuit breaker to protect the electrical circuits from overload. It is located in the base end cover (back of wheelchair for front wheel drive; front of wheelchair for rear wheel drive). In the event of an overload, the circuit breaker button will pop out. To reset the circuit breaker, push the button in.

V OPERATING INSTRUCTIONS

Read and understand all safety precautions before operating your wheelchair.

1. Charge the batteries fully before use. For battery installation and charging information, refer to Section VII, BATTERIES.
2. Engage the drive wheels by turning the **drive engagement levers** to the outside. See the labels that specify ON and OFF on the cowl next to the drive engagement levers; ON for engaged, and OFF for disengaged. The drive engagement levers are located:
 - Front wheel drive:** Toward the front of the wheelchair. Drive engagement levers are pointing toward the rear of the wheelchair when engaged and inward when disengaged.
 - Rear wheel drive:** Toward the rear of the wheelchair. Drive engagement levers are pointing toward the front of the wheelchair when engaged and inward when disengaged.
3. With the joystick in neutral, turn the hand control ON/OFF button ON.
4. Adjust to a low speed or drive profile (if drive profiles have been programmed).
5. Move the joystick gently in the direction in which you wish to travel. If you desire a higher speed, adjust the speed/profile increase button.
6. To stop the wheelchair, release the joystick to the neutral (center) position. The control system will bring the wheelchair to a smooth stop. Upon stopping, electromechanical park brakes will engage to prevent the wheelchair from rolling.
7. Attempting to overcome a stall condition may trip the circuit breaker located in the base end cover. In the event of an overload, the circuit breaker button will pop out. To reset the circuit breaker, push the button in.
 - Front wheel drive:** The base end cover / circuit breaker is located at the rear of the wheelchair.
 - Rear wheel drive:** The base end cover / circuit breaker is located at the front of the wheelchair.

VI ADJUSTMENTS

The Everest with Captain Seat offers several adjustments to make it easier and more comfortable to drive. Adjustments are divided by component: Arm, Back, Headrest, Seat, Cowl, Front Rigging.

Section VIII, MAINTENANCE, offers preventive maintenance suggestions for keeping your wheelchair in excellent condition; ensure that all components are in excellent condition before adjusting. The following are recommended methods; after a few adjustments, you may develop your own. Always consult your qualified Graham-Field Health Products dealer for assistance.

The person performing adjustments on the Everest with Captain Seat has the responsibility of making certain that the user can safely operate the wheelchair with the adjustments selected. This person must evaluate the user's ability, weight, physical condition, the environment in which the wheelchair will be used, and the terrain over which the wheelchair will travel.

Specific tools needed to perform each adjustment are identified in adjustment sections. A complete list of tools needed to perform all adjustments in Section VI follows:

Cable ties
M13 wrench
M10 wrench
M8 wrench
M5 hex key
M4 hex key

⚠ WARNING: Ensure that the wheelchair power switch is in the OFF position before performing adjustments.

ARM—CONTROLS

Adjust hand control extension backward & forward

Tools needed: M4 hex key

The hand control can be moved forward and backward along arm:

1. Use M4 hex key to loosen—not remove—set screw shown in picture at right.
2. Slide extension within arm extension tube to preferred position.
3. Use M4 hex key to tighten set screw.

⚠ WARNING: Ensure that hand control extension is locked in place before occupying or operating wheelchair.

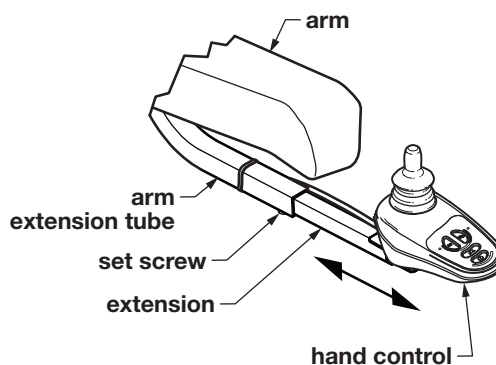

adjust hand control extension backward / forward

Adjust hand control extension—change sides

Tools needed: M13 wrench, M5 hex key, cable ties

The hand control can be mounted on either the left or right side. Only the side with the hand control has an arm extension tube, as shown in picture at right. To change sides, you will remove both upper arms and switch them (in picture at right, hand control is shown mounted on the right arm):

1. Engage the drive wheels (with the drive engagement levers) and turn wheelchair power off.
2. Find the end of the hand control cable and disconnect the hand control connector from the extension cable connector where it emerges from a hole in the cowl.
3. Use M13 wrench and M5 hex key to remove hardware that secures upper arm to lower arm.
4. Slide upper arm free of lower arm. Take care that hand control does not fall.
5. Repeat stems 3 and 4 for other arm.
6. Install arms in opposite positions.
7. Install mounting hardware that secures upper arm to lower arm. Use M13 wrench and M5 hex key to tighten hardware. Repeat for other arm.
8. Connect the hand control connector to the extension cable where it emerges from a hole in the cowl.
9. Ensure that the hand control cable won't catch on anything in its new position. As shown in picture, cable ties secure the cable to the arm extension tube and the upper arm, to prevent its catching on anything. If cable is loose and could possibly catch on anything, use a cable tie to secure it to a part of the frame where it will not contact any moving parts.

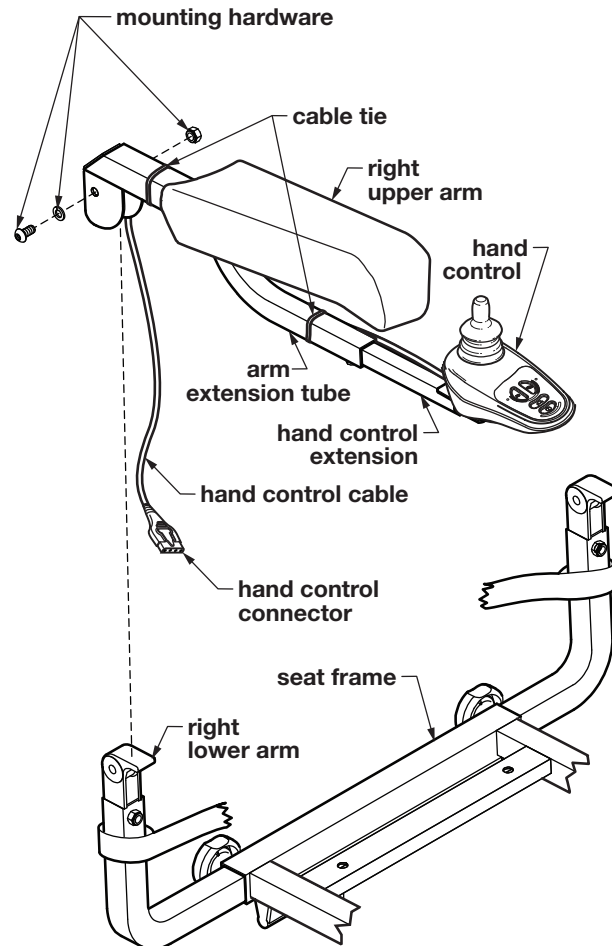

adjust hand control extension—
change sides
(seat and back not shown)

⚠ WARNING: Ensure that arms are securely mounted, extension is securely mounted, cables are secured, and that cables are away from all moving parts before occupying or operating wheelchair.

Adjust arm space from seat frame (width between arms)

Arm space from wheelchair is adjustable by changing the position of the lower arm tube in the seat tube. Both arms are independently adjustable.

1. Turn adjustment knob to free lower arm tube to move inside seat tube (see picture at right).
2. Slide lower arm tube to desired position inside seat tube.
3. Turn knob to secure lower arm tube inside seat tube. Ensure that knob is tightened enough to hold lower arm tube firmly in place.
4. Perform steps 1-3 for other arm.
5. Ensure that both arms are mounted at the same distance from seat frame.

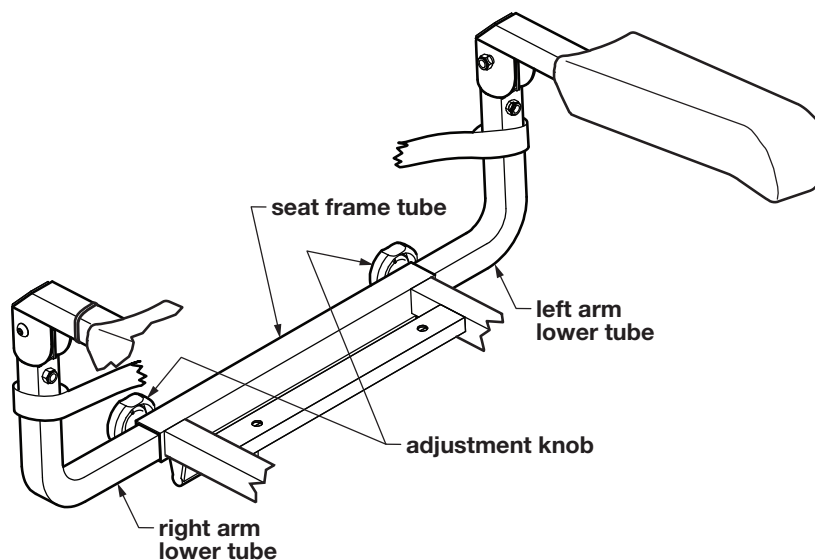

**adjust arm space from seat frame
(width between arms)**

⚠ WARNING: Ensure that lower arm tubes are locked in place before occupying or operating wheelchair.

Adjust arm height

Tools needed: M5 hex key

Arm height is adjustable by removing the screw that secures the upper arm inside the lower arm tube and moving the upper arm to a new position. There are three positions approximately $\frac{5}{8}$ inch apart.

1. Use M5 hex to remove the screw that secures the upper arm in the lower arm tube (see picture at right).
2. Slide upper arm to desired position inside lower arm tube.
3. Reinstall screw. Use M5 hex key to tighten.
4. Perform steps 1-3 for other arm.
5. Ensure that both upper arms are mounted at the same height.

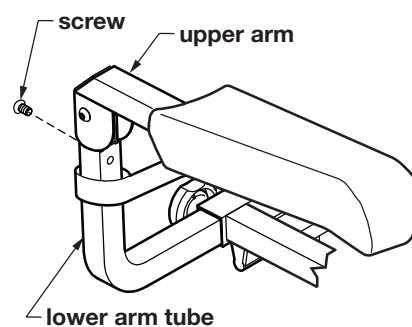

adjust arm height

⚠ WARNING: Ensure that arms are secure before occupying or operating wheelchair.

BACK

Fold back down

1. Engage the drive wheels (with the drive engagement levers) and turn wheelchair power off.
2. Pull up on latch at left side of seat. Hold back by top and push it down, toward front of wheelchair.
3. To restore the back to upright position, pull it back up until latch locks into place. Ensure that latch is locked in place.

⚠ WARNING: Ensure that back is locked in upright position before occupying or operating wheelchair.

Adjust back angle

The back angle is adjustable to five positions.

1. Engage the drive wheels (with the drive engagement levers) and turn wheelchair power off.
2. Pull up on latch at left side of seat. Move back to desired angle.
3. Let go of back when latch locks into place. Ensure that latch is locked in place.

⚠ WARNING: Ensure that back is locked in upright position before occupying or operating wheelchair.

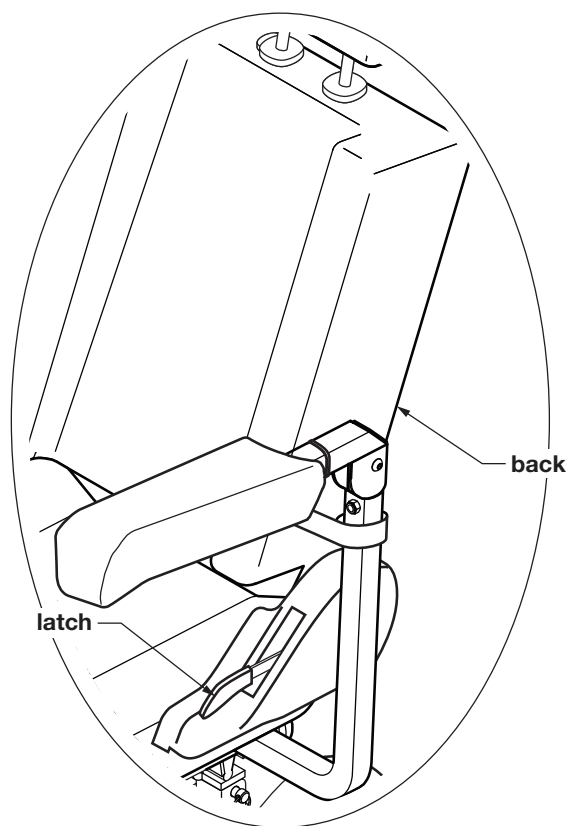

adjust back angle

HEADREST

The headrest is adjustable to four positions, by depressing the button latch on the left headrest post (see picture at right).

Adjust headrest height

1. Depress the button latch with one hand. With the other hand, move the headrest up or down to desired position.
2. Release when button latch has locked into place. Ensure that button latch is locked in place.

⚠ WARNING: Ensure that headrest is locked in place before occupying or operating wheelchair.

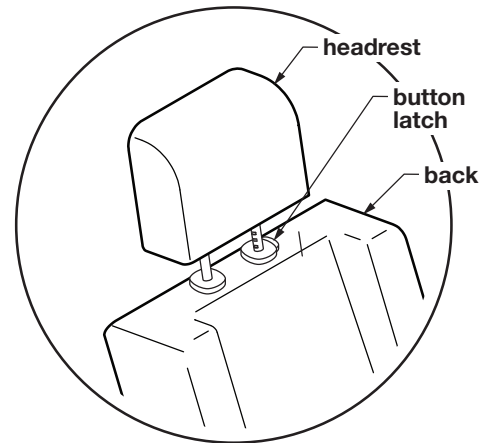

adjust headrest height

SEAT

You must remove the Everest with Captain Seat seat in order to perform certain seat height adjustments.

Note: Removing the seat is best performed with a partner so that you are able to use both hands to remove the seat.

Remove seat (refer to the pictures at right)

1. Engage the drive wheels (with the drive engagement levers) and turn wheelchair power off.
2. Find the end of the hand control cable and disconnect the hand control connector from the extension cable connector where it emerges from a hole in the cowl.
3. Two locking pins secure the seat frame to the base frame at the front of the wheelchair. Remove these two locking pins.
4. Lift the seat up and off the base, moving the seat slightly forward to disengage the seat frame from the hooks at the back of the base that secure seat frame to base frame.

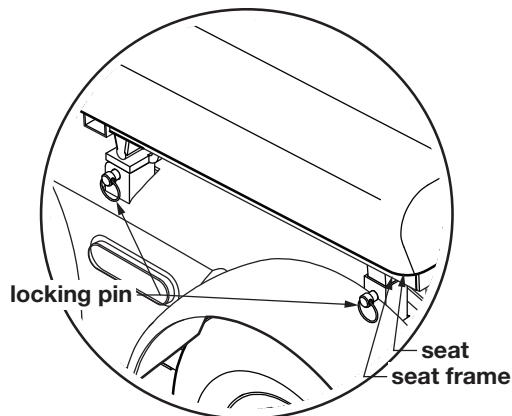

seat installed

Install seat (refer to the pictures at right)

1. Slide the seat down and onto the base frame. Engage the rear seat frame hooks with the rear base frame hooks; engage the front seat frame mount tubes with the base frame front mount tubes. Ensure that rear seat frame hooks are engaged with rear base frame hooks before continuing.
2. Install the two locking pins that secure the seat frame to the base frame at the front of the wheelchair.
3. Connect the hand control connector to the extension cable connector where it emerges from a hole in the cowl.

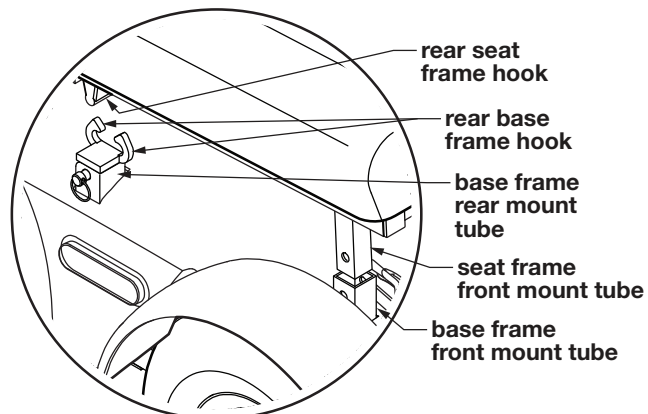

seat removed

⚠ WARNING: Ensure that rear seat frame hooks are engaged with rear base frame hooks and that all four locking pins are locked in place before occupying or operating wheelchair.

Adjust seat height (refer to the pictures on previous page)

Seat height has approximately one inch of adjustment. A small degree of extra tilt can also be gained by placing the front of the seat in a higher position than the back of the seat.

1. Remove seat: Follow steps 1-4 in **Remove seat** on preceding page.
2. Remove the two locking pins that secure the rear seat mounts to the base frame at the rear of the wheelchair.
3. Remove the two rear seat mounts and reinstall them in the desired position. Ensure that both rear seat mounts are installed in identical positions.
4. Install the two locking pins that secure the rear seat mounts to the base frame.
5. Install seat: Follow steps 1-3 in the earlier section, **Install seat**.

⚠ WARNING: Do not adjust seat height so that back is higher than front; this is an unsafe position.

COWL

Remove cowl (refer to the picture at right)

1. Remove seat: Follow steps 1-4 in the earlier section, **Remove seat**.
2. Remove the two locking pins that secure the rear seat mounts to the base frame at the rear of the wheelchair.
3. Remove the two rear seat mounts.
4. Ensure that drive engagement levers are engaged, so that levers will fit through slots in cowl when cowl is lifted over them.

Front wheel drive: Drive engagement levers are pointing toward the rear of the wheelchair when engaged.

Rear wheel drive: Drive engagement levers are pointing toward the front of the wheelchair when engaged.

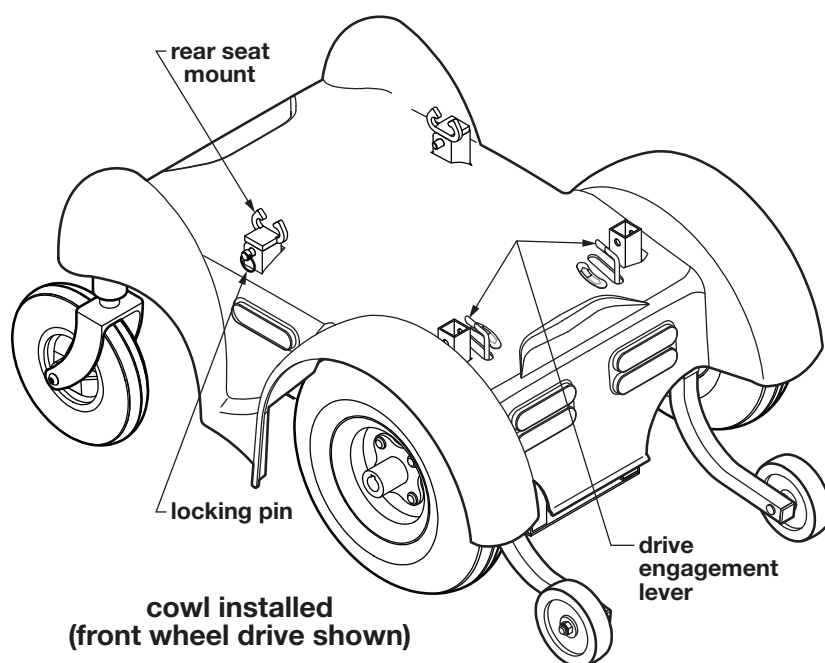

5. Lift cowl up and off base frame. There are Velcro® strips at front and rear that secure cowl to base frame; you must pull these loose to remove the cowl. *

* **Velcro** is a registered trademark of Velcro Industries B.V.

Install cowl (refer to the picture above)

1. Slide the cowl down onto the base frame. Press on the areas at front and rear where the Velcro strips fasten the cowl to the base frame. Ensure that the cowl is securely fastened to the base frame at these points.
2. Install the two rear seat mounts. Ensure that both rear seat mounts are installed at the same height.
3. Install the two locking pins that secure the rear seat mounts to the base frame.

FRONT RIGGING—CENTER-MOUNT FOOTREST

⚠ WARNING: Ensure that the lowest point on the footplates clears the ground safely during ascent or descent.

Flip footplates up (see picture at right)

Hold the footplates by the front and fold them up against the center tube.

Adjust footplate extension length (see picture at right)

Footplate extension length is adjustable in two ways. You can either adjust footplate extension length individually by loosening the knob and moving it to a different adjustment hole, or adjust the position of the footplate extension assembly on the seat frame bracket.

Adjust individual footplate extension length

1. Unscrew and remove adjustment knob.
2. Move footplate up or down in center tube to adjust footplate to desired position.
3. Install and tighten knob.
4. Repeat for other footplate. Ensure that knobs are secure before occupying or operating wheelchair.

Adjust position of footplate extension assembly on seat frame bracket

Tools needed: M10 wrench, M4 hex key

1. Use M10 wrench and M4 hex key to remove mounting nuts and bolts, and remove footplate extension from seat frame bracket.
2. Reposition center tube in desired position on seat frame bracket.
3. Reinstall mounting nuts and bolts. Use M10 wrench and M4 hex key to tighten.

⚠ WARNING: Ensure that all parts of footrests are secure, and that footplate extension assembly is securely mounted on seat frame, before occupying or operating wheelchair.

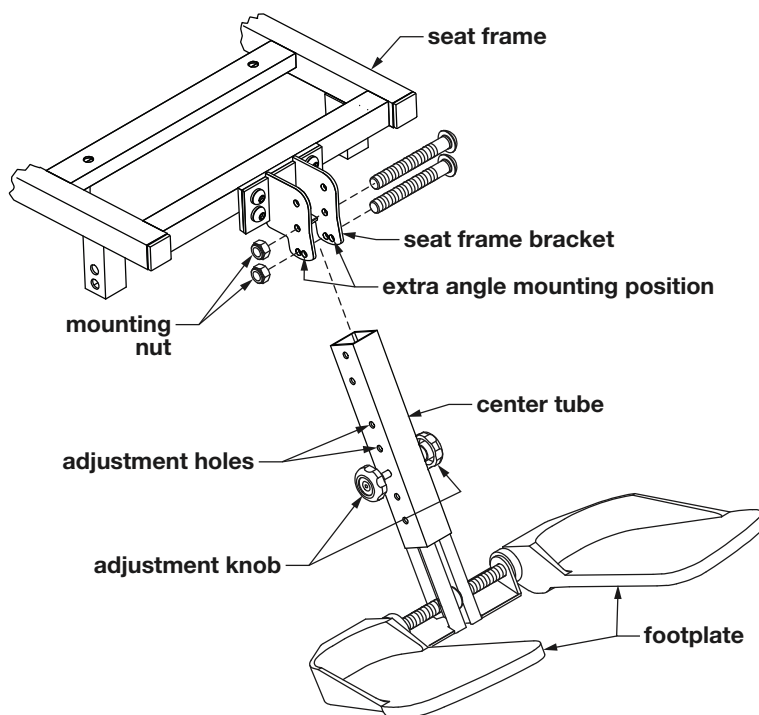

VII BATTERIES

Batteries are of critical importance, require attention and maintenance, and will require periodic replacement. As batteries age, their ability to hold a charge decreases. Old batteries discharge much more quickly than new batteries under the same driving conditions. This results in a decrease in the distance the wheelchair can travel before batteries need to be charged. This decrease is often misinterpreted as a problem with the wheelchair system, when in fact the batteries have simply reached the end of their useful lives and should be replaced. Properly maintained batteries can be expected to last approximately 9 to 18 months. The purpose of proper maintenance is to extend that life as much as possible, and to minimize the incidence of unsatisfactory wheelchair performance.

The Everest with Captain Seat uses two 12 volt deep cycle batteries, group size U1 or 22. For best performance, batteries with the highest possible amp-hour rating should be used.

▲ **Caution:** Only deep cycle, sealed case construction batteries should be used in this device.

⚠ **WARNING:** Batteries contain sulfuric acid, which can burn eyes, skin, clothes, etc. Use caution! Always wear safety glasses when working with batteries. If contact occurs, flush immediately with water and get medical attention.

GUIDELINES TO EXTENDING BATTERY LIFE

- Give the batteries a full charge before using them for the first time.
- Limit use of new batteries for the first ten charge/discharge cycles—avoid deeply discharging the batteries. New batteries are not capable of their rated output until they have been discharged a number of times.
- Recharge batteries after every discharge. Discharging batteries deeply before recharging them will shorten battery life. Do not leave partially discharged batteries idle for several days; charge them as soon as possible after discharging.
- Charge batteries fully each time before using. Allow the charger to finish its charge cycle once started. This will help prevent deeply discharging the batteries. Unlike some rechargeable batteries, the batteries used on wheelchairs do not exhibit a significant “memory effect”—they will recharge to their full capacity, even if only partially discharged before each charge.
- If you must store your wheelchair for a long period of time, charge the batteries weekly.
- Perform regular maintenance on the batteries. See maintenance schedule in Section VIII, MAINTENANCE, for recommended regularity.

BATTERY CHARGER

The Everest with Captain Seat 5-amp battery charger, included with the wheelchair, is pictured and described below. This battery charger is capable of charging both gel and sealed lead acid batteries. Please read this entire section, including **SAFETY—CHARGING THE BATTERIES**, before charging your batteries.

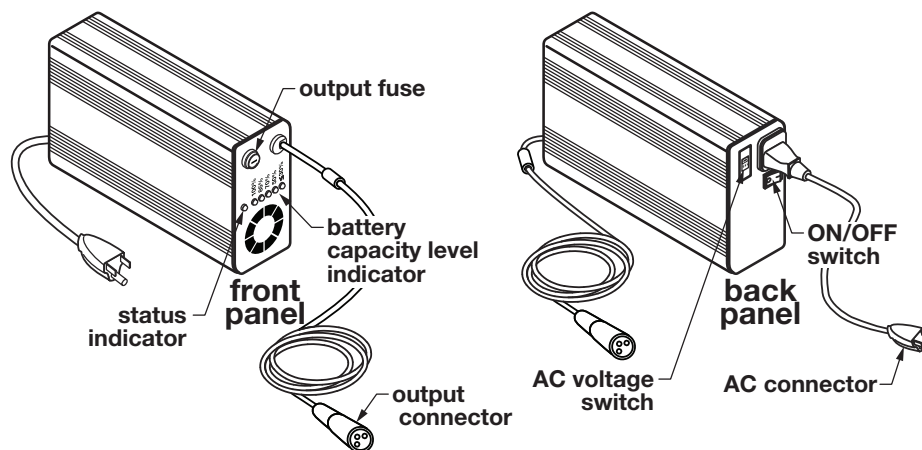

Battery charger front panel

Output cable and connector

The output connector plugs into the battery charger receptacle on the underside of the hand control to charge the batteries.

Status indicator

Green LED illuminates when battery charger power is switched on, then flashes a different pattern for each charging mode (fast charge, deep charge, float charge, or maintain).

Battery capacity level indicator

One red or yellow LED illuminates at a time to show state of battery charge: ≤30% (red), 50% (red), 70% (yellow), 85% (yellow), or 100% (yellow).

Output fuse

See **Check/replace the output fuse** in **TROUBLESHOOTING** for directions on changing the output fuse.

Battery charger back panel

ON/OFF switch

The ON/OFF switch turns battery charger power on and off.

AC voltage switch

The AC voltage switch changes the voltage between 115 volts and 230 volts. Set to 115 volts for use in the U.S. and Canada. See **Battery voltage switch on wrong setting** in **TROUBLESHOOTING** for directions on switching voltage.

AC connector

The AC connector plugs into the power outlet to charge the batteries.

SAFETY—CHARGING THE BATTERIES

- ⚠ WARNING:** Do not use a household extension cord if the charger plug does not reach the 115 volt outlet. Use of an improper extension cord could result in fire and electric shock. If an extension cord must be used, use a three conductor No. 16 AWG (or heavier) cord with ground, properly wired, in good electrical condition, and keep it as short as possible.
- ⚠ WARNING:** Do not use cords that are damaged or defective. Use of a damaged or defective cord could result in fire or electric shock.
- ⚠ WARNING:** Locate all battery charger cords so that they will not be stepped on, tripped over, or otherwise subjected to damage or stress.
- ⚠ WARNING:** To prevent electrical shock, do not touch uninsulated parts of the battery charger output connector, battery connectors, or battery terminals. Ensure that all electrical connectors are in good working condition. Do not use connectors that are cracked, corroded, or do not make adequate electrical contact. Use of a damaged or defective connector could result in fire or electric shock.
- ⚠ WARNING:** Ensure that the area around battery charger and batteries is well ventilated while batteries are being charged. Do not allow clothing, blankets, or other material to cover battery charger. Do not place battery charger under a bed.
- ⚠ WARNING:** Keep sparks, flame, and smoking materials away from batteries. No smoking!
- ⚠ WARNING:** Battery chargers can ignite flammable materials and vapors. Do not use near fuels, grain dust, solvents, thinners, or other flammables.
- ⚠ WARNING:** Batteries generate gases which can be explosive. To prevent arcing or burning near batteries, do not disconnect battery charger output connector from wheelchair battery charger receptacle when battery charger is operating. If the charge cycle must be interrupted, move the battery charger ON/OFF switch to OFF and disconnect the battery charger AC connector from the power outlet, then disconnect the battery charger output connector from the wheelchair battery charger receptacle.
- ⚠ WARNING:** To avoid damage to any of the battery charger connectors and their cords, disconnect by grasping the plug body and pulling it straight out of the outlet or receptacle. DO NOT pull on the cord. DO NOT twist, rock or pull the connector sideways.

⚠ WARNING: Do not use battery chargers not supplied by Graham-Field Health Products. Battery chargers not supplied by Graham-Field Health Products could damage the controller and the battery charger. Electrical arcing could result, which could cause severe personal injury, explosion, and fire.

Charging the batteries

Note: Before charging the batteries, read the rest of this manual, especially the Battery Charger section.

Note: As a safety feature, the wheelchair is inoperable during charging.

1. Ensure that power to both wheelchair and battery charger is OFF.
2. Connect battery charger output connector to receptacle on bottom of hand control.
3. North America: Plug the battery charger AC connector into a properly grounded, 115 volt, 60 cycle single phase power outlet.

Note: Ensure that the battery charger AC voltage switch is set on the appropriate voltage for your location.

4. Place battery charger power switch in the ON position. The green status indicator LED will illuminate when battery charger power is switched on, then flash a different pattern for each charging mode automatically selected by the battery charger:

Always off: No AC power

Always on (nonflashing): Batteries not connected

Flash 1/2 second on, 1/2 second off: Fast charge (normal charge)

Flash 2 seconds on, 2 seconds off: Float charge (almost finished)

Flash 4 times, 1 second on, 1 second off: Maintain charge (charge complete)

Flash 2 times, 1 second off: Deep charge (batteries severely discharged)

The battery capacity level indicator LEDs will illuminate one at a time to show the state of battery charge: ≤30% (red), 50% (red), 70% (yellow), 85% (yellow), or 100% (yellow).

When the batteries are fully charged, the battery capacity level indicator's 100% LED will illuminate and the status indicator will show maintain mode.

5. Allow adequate time to bring the batteries up to a full charge—the actual time required to recharge the batteries will depend on discharge condition. The charger supplied with the wheelchair is automatic, and will not damage the batteries if left connected after batteries are fully charged.
6. When batteries are fully charged, place battery charger power switch in the OFF position.
7. Remove battery charger output connector from hand control receptacle.

Note: If you experience a problem with your battery charger, please see Troubleshooting, battery charger in the TROUBLESHOOTING section

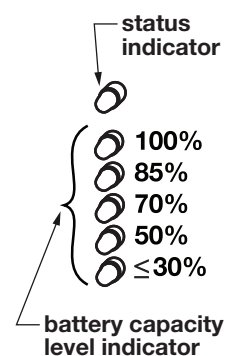

REMOVE AND INSTALL BATTERIES

⚠ WARNING: Batteries can supply a large amount of current. Do not wear jewelry or watches when working on batteries. Take care not to connect the terminals accidentally with anything metal; severe burns could result.

REMOVE BATTERIES

Tools needed: Group 22 batteries: two 1/2" wrenches; U1 batteries: two 7/16" wrenches

⚠ WARNING: Ensure that wheelchair power is off before removing batteries.

To access the batteries, you will first remove the seat and cowl.

1. Please see Section VI, ADJUSTMENTS, SEAT, Remove Seat, and perform steps 1-4.
2. Please see Section VI, ADJUSTMENTS, COWL, Remove Cowl, and perform steps 1-5.
3. The base frame and batteries will then be exposed.
4. Unfasten battery straps.
5. Disconnect black connectors at each battery that connect battery cables to power cable.
6. Lift batteries up and out of base frame.
7. Remove battery cables from both batteries:

Group 22 batteries: Use two 1/2" wrenches to remove nuts and screws that secure wire terminals to battery terminals. Set aside for reassembly.

U1 batteries: Use two 7/16" wrenches to remove nuts and screws that secure wire terminals to battery terminals. Set aside for reassembly.

INSTALL BATTERIES

Note: If you are changing battery size, you will need to reposition the brackets that keep the batteries secure in the base frame. The brackets should be snug enough to keep the batteries from moving.

Adjust battery brackets (if necessary)

Tools needed: M4 hex key

1. Use M4 hex key to loosen screws enough so that bracket is free to move along slots. Reposition bracket in desired location.
2. Use M4 hex key to tighten screws so that bracket does not move.
3. Repeat for other bracket.

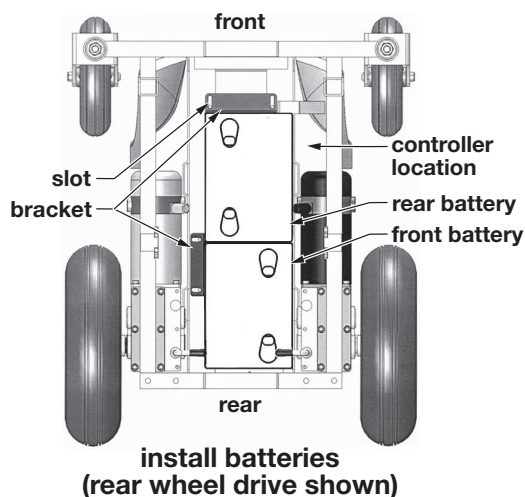

Install batteries

Tools needed:

Group 22 batteries: two 1/2" wrenches; U1 batteries: two 7/16" wrenches

Note: Observe controller location: front wheel drive controller is located at left rear; rear wheel drive controller is located at right front. Position the battery adjacent to the controller with its battery terminals away from the controller, to reduce the possibility of arcing. Position the other battery with its terminals on the opposite side from the first battery as shown below, to allow maximum space for routing cables.

1. Place batteries lengthwise in base frame, as shown at right.

Group 22 batteries: Install battery cable positive wire terminal (+) on positive battery terminal (+) of first battery as shown above. Use two 1/2" wrenches to secure. Install battery cable negative wire terminal (-) to negative battery terminal (-) of first battery as shown. Use two 1/2" wrenches to secure.

U1 batteries: Install battery cable positive wire terminal (+) on positive battery terminal (+) of first battery as shown above. Use two 7/16" wrenches to secure. Install battery cable negative wire terminal (-) to negative battery terminal (-) of first battery as shown. Use two 7/16" wrenches to secure.

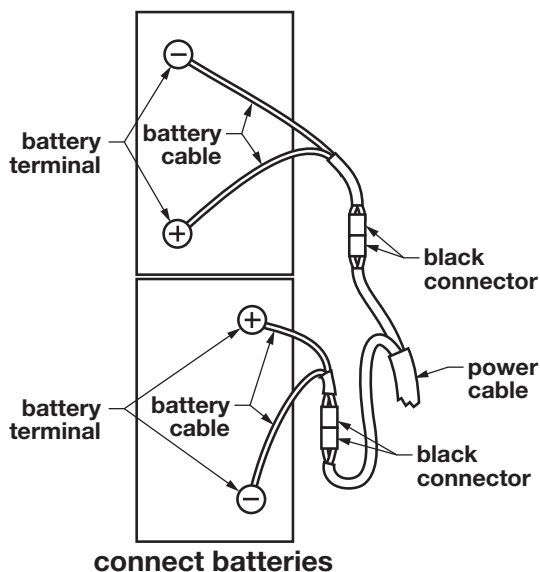

-
2. Install second battery cable as described in step 1.
 3. Ensure that all wires are connected as specified. Ensure that all connections are secure.
 4. To retard corrosion, coat battery posts and terminals with petroleum jelly after all connections are made.
 5. Connect black connectors that connect battery cables to power cable.
 6. Fasten battery straps.
 7. Replace the cowl. Please see **ADJUSTMENTS, COWL, Install cowl**, and perform steps 1-3.
 8. Replace the seat. Please see **ADJUSTMENTS, SEAT, Install seat**, and perform steps 1-3.
 9. Ensure that the circuit breaker located in the end cover is properly set by depressing its button (back of wheelchair on front wheel drive, front of wheelchair on rear wheel drive).
 10. Do not attempt to operate the wheelchair unless batteries are installed as instructed above.
 11. Do not attempt to operate wheelchair until batteries are fully charged.

⚠ WARNING: Ensure that batteries are installed as described before operating wheelchair.

⚠ WARNING: Ensure that cowl is securely fastened to base frame, rear seat frame hooks are engaged with rear base frame hooks, and that all four locking pins are locked in place before occupying or operating wheelchair.

⚠ WARNING: Ensure that all cables are away from the moving parts of the wheelchair.

REGULAR BATTERY MAINTENANCE

⚠ WARNING: Batteries can supply a large amount of current. Do not wear jewelry or watches when working on batteries. Take care not to connect the terminals accidentally with anything metal; severe burns could result.

⚠ WARNING: Batteries contain sulfuric acid, which can burn eyes, skin, clothes, etc. Use caution! Always wear safety glasses when working with batteries. If contact occurs, flush immediately with water and get medical attention.

Clean batteries

Needed: baking soda

1. You will first need to remove the batteries; see **Remove batteries** in previous **REMOVE AND INSTALL BATTERIES** section—follow steps 1-7.
2. Clean outside of batteries, and inside and outside of battery box, with a solution of one tablespoon baking soda to ten ounces water.
3. Rinse with clear water. Allow to dry.
4. Ensure that batteries and connectors are clean and dry. Reinstall batteries; see **Install batteries** in previous **REMOVE AND INSTALL BATTERIES** section—follow steps 1-11.

Clean battery terminals

Tools needed: wire brush or battery terminal cleaning tool

1. You will first need to remove the batteries; see **Remove batteries** in previous **REMOVE AND INSTALL BATTERIES** section—follow steps 1-7.
2. Clean all battery terminals and clamps with a wire brush or battery terminal cleaning tool (this can be purchased at most auto parts stores).
3. Reinstall batteries; see **Install batteries** in previous **REMOVE AND INSTALL BATTERIES** section—follow steps 1-11.

VIII MAINTENANCE

Protect your Everest & Jennings® Everest with Captain Seat by having it serviced regularly. Proper care and maintenance are essential to keep your wheelchair in safe working condition. Periodic inspection, adjustment, and replacement of worn parts will provide many years of superb performance. When you believe that a component or part of your Everest with Captain Seat is not functioning properly, immediately contact your Graham-Field Health Products dealer, as a potentially hazardous condition could result. Only excellent condition is acceptable where safety is concerned.

Service manual

There is no service manual for the Everest with Captain Seat. Please contact your Graham-Field Health Products dealer with service questions not answered by this manual.

Note: Graham-Field Health Products recommends that you have a qualified dealer perform a six month maintenance check, as the dealer may find and correct a problem which might otherwise go undetected and eventually cause more serious problems and/or personal injury.

Do-it-yourself maintenance

You can do many of the scheduled maintenance tasks yourself, if you have mechanical ability and a few basic tools. Refer to the maintenance schedule below for the recommended regularity of each procedure. If any maintenance procedure is not clear to you, ask your Graham-Field Health Products dealer for assistance.

MAINTENANCE SCHEDULE						
Procedure	Perform at least every					
	Day	Week	2 weeks	month	3 months	6 months
Charge batteries	✓					
Check joystick	✓					
Check cables & connections		✓				
Check tire wear		✓				
Check controller & park brakes		✓				
Check anti-tippers		✓				
Wipe off base and seat frame		✓				
Check arms				✓		
Check footrests				✓		
Check & clean upholstery				✓		
Clean base and seat frame					✓	
Clean batteries					✓	
Check caster forks					✓	
Clean battery terminals						✓
Inspect motor brushes						✓
Check bearings						✓
Check battery state-of-charge as needed						

▲ **Caution:** Improper maintenance can cause operating problems and may affect your warranty.

⚠ **WARNING:** **Unauthorized modification or the use of non-Everest & Jennings® replacement parts could change the structure of the wheelchair, void the warranty, and create a hazardous condition resulting in serious personal injury.**

List of tools and supplies

The tools and cleaning supplies listed will assist in the procedures outlined in Section VIII.

- Soft cloth
- Mild soap and water solution

General care

Always evaluate the overall operation of your wheelchair. It should function with ease and should travel straight without excessive drag or pull to one side.

Remember, your qualified Graham-Field Health Products dealer knows your wheelchair best when it comes to service and repairs. Contact your dealer with any questions or concerns regarding the safe operation and maintenance of your wheelchair. Regular maintenance is important for your safety and continued operation of your wheelchair.

Charge batteries

Charge the batteries daily. See Section VII, **BATTERIES, Charging the batteries**.

Check joystick

Check the hand control joystick daily. Turn wheelchair power off. Check that the joystick is not bent or damaged, and that it returns to center when you release it. If there is a problem, do not operate the wheelchair. Contact your dealer.

Check the rubber boot around the base of the joystick for damage or splitting. A visual check is sufficient—do not handle the boot. If there is a problem, contact your dealer.

There are no serviceable parts in the controller or hand control. If you have problems with these components, see Section IX, **TROUBLESHOOTING**; if you are unable to resolve them, contact your Graham-Field Health Products dealer.

Check cables and connections

Inspect all control system plug connectors visually at least once a week to be sure that they are securely fastened. Cable connections for both front wheel drive and rear wheel drive wheelchairs are shown on the following pages.

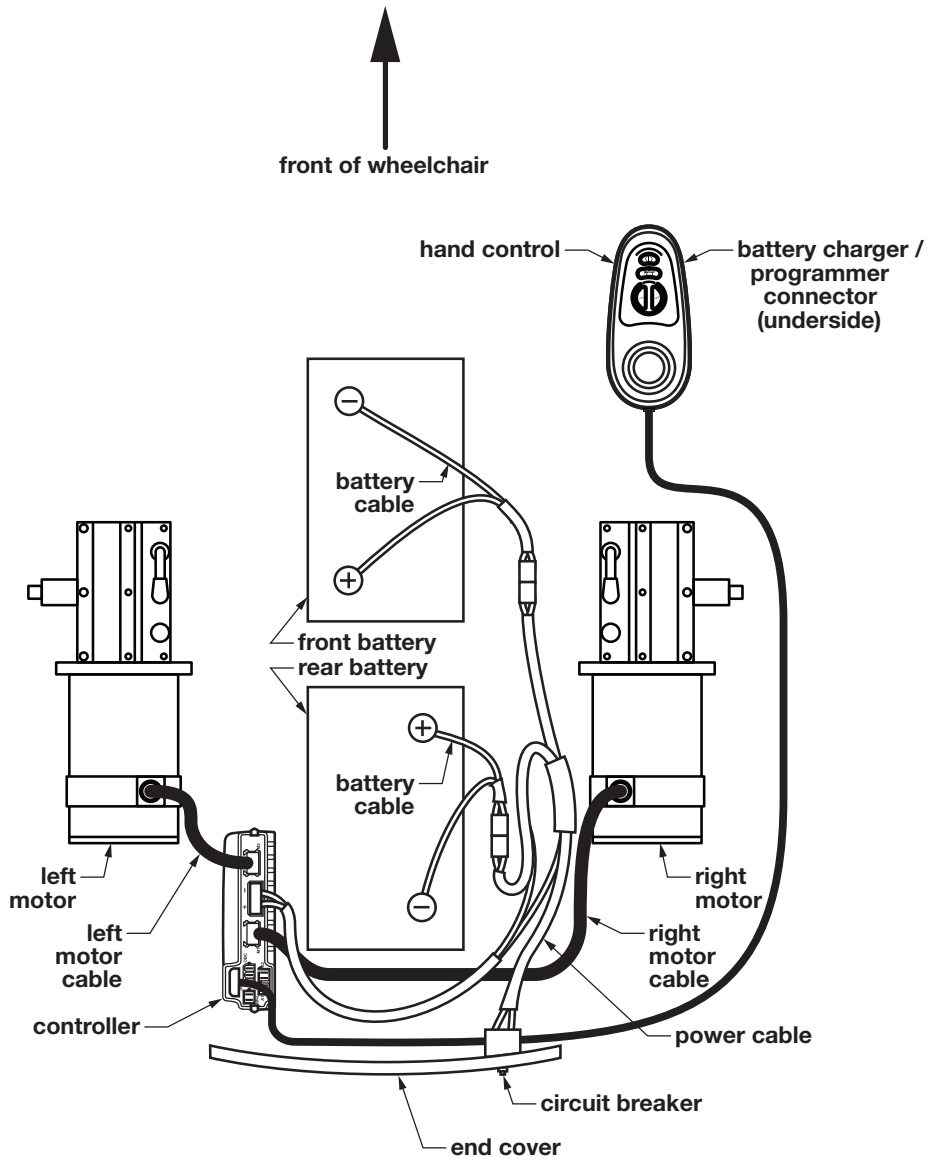

**control system cable connections,
front wheel drive**

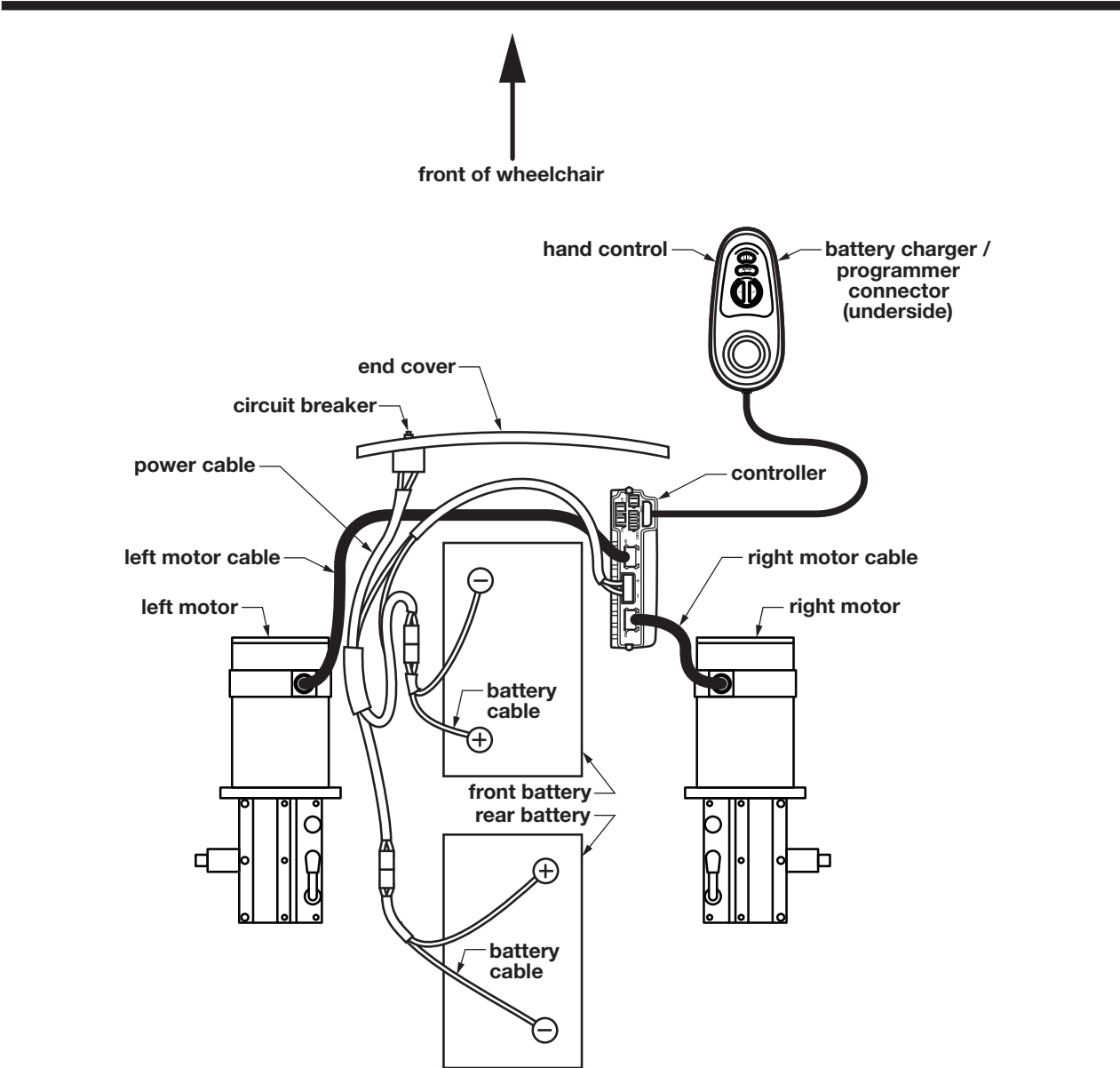

**control system cable connections,
rear wheel drive**

Check tires

Examine tires at least once a week for surface wear and cracks and replace them as needed. Tires should be replaced when they become loose on the rims or cracks appear.

Check controller & park brakes

Perform the following at least once a week. It should be carried out on a level floor in a quiet area with at least one meter (40 inches) of clear space around the wheelchair.

Turn wheelchair power on. Check that after one second the power indicator lights remain on. Push the joystick slowly forward until you hear the brakes release. The wheelchair may start to move. Immediately release the joystick—you must be able to hear the park brakes operate within a few seconds. Repeat the test three times, pushing the joystick in reverse, left and right, respectively. If there is a problem, do not operate the wheelchair. Contact your dealer.

Repairs of the electromechanical park brakes, which keep your Everest with Captain Seat from rolling when stopped, should only be performed by an Graham-Field Health Products dealer.

Check anti-tippers

Check the anti-tippers at least once a week. Ensure that all parts of the anti-tippers are securely fastened.

Clean frame

Needed: soft cloth, mild soap and water solution

Wipe off base and seat frame frequently, at least once a week, using a soft cloth. Dry the wheelchair immediately if exposed to moisture. Clean frame every three months with a mild soap and water solution. The frame does not need to be waxed. Do not use solvents, abrasive waxes, caustic chemicals or spray silicone. Never use abrasive cleansers; they could scratch the finish. Never use steam or high pressure cleaners.

Check & clean upholstery

Needed: soft cloth, mild soap and water solution

Check back and seat upholstery material at least once a month. Inspect for rips, tears and worn spots.

Clean back and seat upholstery material at least once a month with a soft cloth and a mild soap and water solution.

Check arms

Check arms at least once a month. Inspect for sharp edges or cracks which could weaken the armrest. Ensure that all attaching hardware is present and tight.

Check footrests

Check footrests at least once a month. Inspect the mounting hardware to confirm secure fasteners. Check for cracks, burrs or sharp edges. Ensure that the footplate extension knobs are secure and footplates will not accidentally slip.

Check caster forks

Check the caster stems/forks for proper rotation at least every three months. The caster fork must swivel freely to facilitate steering and handling. Adjusting the stem nut varies the amount of force required to turn the caster. If the nut is too loose, the caster will flutter or shimmy; if the nut is too tight, the wheelchair will be difficult to steer. If the caster requires adjustment, or the caster stem bearing requires replacement, visit a qualified Graham-Field Health Products dealer. Ensure that stems are firmly attached to forks, and that forks and stems are not bent. Evaluate all threads, locking nuts and bearings.

Clean Batteries

Perform this at least every three months. See Section VII, **BATTERIES, REGULAR BATTERY MAINTENANCE, Clean batteries**, for this procedure.

Clean battery terminals

Clean battery terminals at least every six months. See Section VII, **BATTERIES, REGULAR BATTERY MAINTENANCE, Clean battery terminals**, for this procedure.

Inspect motor brushes

The motor brushes should be inspected for wear every six months and replaced as needed. This should be performed by a Graham-Field Health Products dealer.

- ▲ **Caution:** Badly worn brushes can result in damage to the motors or controller.
- ▲ **Caution:** After replacing the brushes, run the wheelchair gently for the first few miles to allow the brushes to seat properly.

Check bearings

The Everest with Captain Seat has bearings only in the caster wheels, not in the drive wheels. Always be alert for unusual noises in the bearings or excessive caster wobble. These signs indicate that the bearings are becoming worn and may require replacement. The caster bearings should be inspected every six months and replaced as needed. This should be performed by a Graham-Field Health Products dealer.

IX TROUBLESHOOTING

SERIAL NUMBER LOCATIONS

Several components of your power wheelchair have been assigned serial numbers at the factory. There may be times when you will need to provide a serial number; for example, if you order replacement parts. The following diagrams are provided to help you find the serial number labels.

Base frame

The base frame serial number label is located at the caster end of the base frame, as shown at right (front of the base frame for rear wheel drive; back of the base frame for front wheel drive).

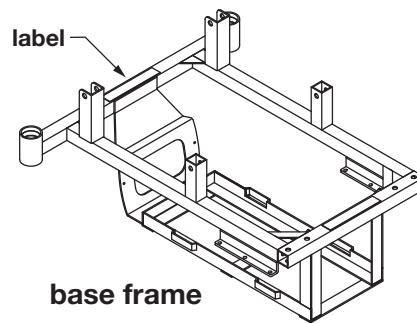

Cowl

The cowl serial number label is located on the underside of the cowl, as shown at right.

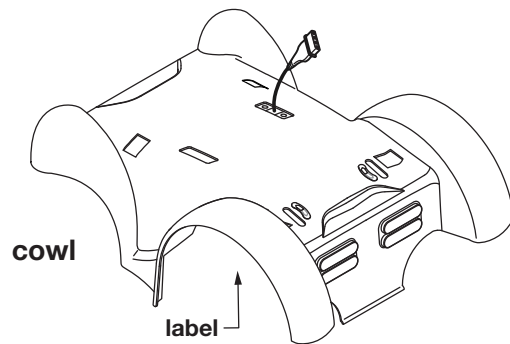

Seat frame

The seat frame serial number label is located at the back of the seat frame, as shown at right.

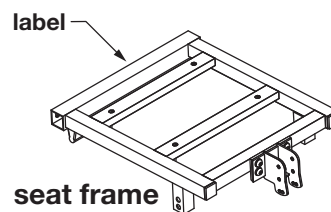

Hand control

The hand control serial number label is located on the underside of the hand control, as shown at right. You must remove the hand control from its mounting bracket to see this serial number label. Please note that the hand control has an additional serial number label on the side, which is not intended to be permanent; you may remove it.

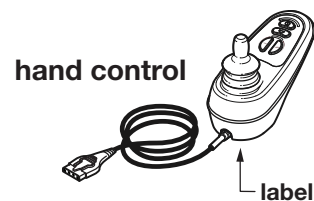

GENERAL TROUBLESHOOTING

Continual use of your Everest with Captain Seat necessitates maintenance, especially if the factory-set adjustments have been altered. If you are unsure of the solution or unable to diagnose the problem, do not hesitate to ask your Graham-Field Health Products dealer for assistance. Most power drive problems are battery related. As batteries age, their ability to hold a charge decreases. Older batteries discharge much more quickly than new batteries under the same driving conditions. This results in a decrease in the distance the wheelchair can travel before batteries need to be charged. This decrease is often misinterpreted as a problem with the wheelchair system, when in fact the batteries have simply reached the end of their useful lives and should be replaced. Sometimes expensive components are unnecessarily replaced when the batteries are the real problem. If an electrical problem exists, check the following:

BATTERIES

Make sure the batteries are fully charged. Test battery state-of-charge as described in Section VII, **BATTERIES, REGULAR BATTERY MAINTENANCE**. Keep the posts and terminals clean and tight.

CIRCUIT BREAKER

Your Everest with Captain Seat is equipped with a circuit breaker to protect the electrical circuits from overload. It is located in the base end cover (front of wheelchair for rear wheel drive; back of wheelchair for front wheel drive). In the event of an overload, the circuit breaker button will pop out. To reset the circuit breaker, push the button in.

Note: If you experience a problem with your wheelchair and are unable to service it yourself, contact the dealer from whom you purchased the wheelchair. If the dealer is unable to help you, contact Graham-Field Health Products Customer Service Department .

Note: Use only Everest & Jennings® replacement parts. An Everest with Captain Seat parts catalog is available through Graham-Field Health Products dealers (and on the internet, at www.graham-field.com), to assist in the ordering of parts.

▲ **Caution::** A complete inspection of your wheelchair, including maintenance, servicing and safety checks, should be handled by a qualified Graham-Field Health Products dealer at least once a year.

⚠ **WARNING: Unauthorized modification or the use of non-Everest & Jennings® replacement parts could change the structure of the wheelchair, void the warranty, and create a hazardous condition, which could result in serious personal injury..**

TROUBLESHOOTING: CONTROLLER

A general diagnostic guide is first, followed by the battery indicator control system status display and the battery indicator diagnostic guide. Use the general diagnostic guide first; if you are unable to solve your problem, use the battery indicator diagnostic guide.

⚠ WARNING: If problems or fault indicators persist, do not attempt to operate the wheelchair. Operation of the wheelchair could be unsafe. Contact the dealer from whom you purchased the wheelchair. If the dealer is unable to help you, contact Everest & Jennings' Customer Service Department for a list of qualified Graham-Field Health Products dealers in your area.

GENERAL DIAGNOSTIC GUIDE





SYMPTOM	BATTERY INDICATOR LIGHTS	POSSIBLE CAUSE	CORRECTIVE ACTION
Wheelchair won't drive	Off	System off	Turn ON/OFF button switch ON
		Batteries not connected	Connect batteries
		Batteries not connected properly, or polarity reversed	Correct Connections
		Circuit breaker open	Reset circuit breaker
		Batteries severely discharged	Recharge / replace batteries
	Rapid flash (even with joystick released)	Control system fault	<p>The Controller safety circuits have operated and the Controller has been prevented from moving the wheelchair. This indicates that there is a fault. Please follow this procedure:</p> <ol style="list-style-type: none"> 1. Switch off the control system. 2. Ensure that all Controller and wheelchair connectors are securely mated. 3. Check battery condition. 4. If you can't find the problem, try using the following Battery indicator diagnostic guide. 5. Turn the Controller on again and try to drive the wheelchair. If the fault lights flash again, do not try to use the wheelchair; see your dealer.
Wheelchair drives	On, steady	All is well	None
	Slow flash	Low batteries	Controller is functioning correctly but you should charge the batteries as soon as possible.
Wheelchair drives, but movement is sluggish	On	Speed control or nonhazardous fault	If the wheelchair does not travel at full speed or does not respond quickly enough, and battery condition is good, check speed control setting. If adjusting the speed control does not remedy the problem, there may be a nonhazardous fault. Call your dealer.
		Speed and response have been programmed slow	Reprogram to desired performance

BATTERY INDICATOR DIAGNOSTIC GUIDE

Battery indicator control system status display

The battery indicator also provides a control system status display. Use the picture at left below to identify the display (the number of lights illuminated), then see the fault, if any, and status / appropriate action at the picture's right.











THE WHEELCHAIR WILL BE OPERABLE WHEN THE FOLLOWING FAULTS OCCUR.

battery level indicator status guide table	SYSTEM FAULT	CHECK / ACTION
 red, yellow, & green lights illuminate	None	Batteries charged; control system OK.
 red & yellow lights illuminate	None	Charge batteries if possible; control system OK.
 red lights only illuminate or flash slowly	None	Low batteries; control system OK. Charge batteries!!!
 red, yellow, & green lights step up & down	Possible joystick fault	Joystick out of neutral—leave joystick in neutral while turning wheelchair power on. Operate joystick to make sure it returns to neutral. Turn ON/OFF button off and ON to reset.

Battery indicator control system fault display

The battery indicator also provides a diagnostic display. When a control system fault occurs, a set of lights will flash. Use the picture at left below to identify the fault code (the number of lights flashing), then see the system fault and appropriate action at the picture's right.

THE FOLLOWING SYSTEM FAULTS WILL PREVENT THE WHEELCHAIR FROM DRIVING.

battery level indicator control system fault diagnostic guide table	SYSTEM FAULT	CHECK / ACTION
 <p>1 light flashing rapidly</p>	Low battery voltage	The battery needs charging or there is a bad connection to the batteries. Check the connections to the batteries and the controller power connector. If the connections are good, try charging the battery.
 <p>2 lights flashing rapidly</p>	Left motor disconnected	The left motor has a bad connection. Ensure that the motor is connected properly and the controller connectors are secure. If problem persists, see dealer. (Check motor brushes)
 <p>3 lights flashing rapidly</p>	Left motor wiring fault	The left motor has a short circuit to a battery connection. See dealer. (Check motor brushes)
 <p>4 lights flashing rapidly</p>	Right motor disconnected	The right motor has a bad connection. Ensure that the motor is connected properly and the controller connectors are secure. If problem persists, see dealer.
 <p>5 lights flashing rapidly</p>	Right motor wiring fault	The right motor has a short circuit to a battery connection. See dealer.
 <p>6 lights flashing rapidly</p>	Inhibit active	The battery charger is preventing the controller from driving the wheelchair. Disconnect charger from wheelchair.
 <p>7 lights flashing rapidly</p>	Possible joystick fault	A joystick fault is indicated. Ensure that joystick is in neutral before turning ON/OFF switch on.
 <p>8 lights flashing rapidly</p>	Possible controller fault	A controller fault is indicated. Ensure that all Controller connections are secure. If problem persists, see dealer.
 <p>9 lights flashing rapidly</p>	Possible park brake fault	The park brakes have a bad connection. Check the park brake & motor connections. Ensure that controller connections are secure. If problem persists, call dealer.
 <p>10 lights flashing rapidly</p>	Excessive voltage	This is usually caused by a poor battery connection. Check the controller and battery connections.
 <p>7 lights + S flashing rapidly</p>	Communication fault	A communication fault is indicated. Ensure that hand control cable is securely connected and not damaged.

TROUBLESHOOTING: BATTERY CHARGER

SYMPTOM

CHECK—ACTION

Green status LED OFF;
Battery capacity level
indicator LED ON

- Check that the battery charger is connected and switched ON.
- Check that the battery charger is plugged into a working power outlet.
- Battery voltage switch on wrong setting—check and ensure that for U.S. and Canada, switch is set to 115V. If not, use a small screwdriver to change to correct setting, as shown in picture at right.
- Check / replace the AC fuse as shown below.

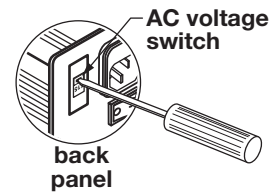

⚠ WARNING: Before checking the AC fuse, disconnect the battery charger from both power outlet and wheelchair battery charger receptacle

1. Hold line connector by its body and pull straight out from battery charger as shown in picture at right.
2. Use a small screwdriver to open AC fuse compartment cover as shown in lower picture at right.
3. Slide AC fuse compartment out from battery charger. There is a spare fuse in the compartment.
4. Replace AC fuse with spare. If spare fuse has been used, replace with same size and type.
5. Replace cover.

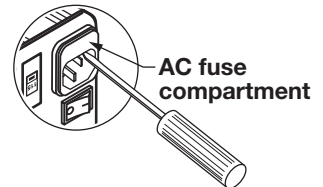
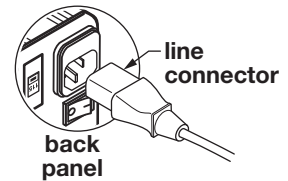

⚠ WARNING: Do NOT replace the AC fuse with the output fuse. They have different fuse ratings, and interchanging them could result in fire.

Battery charger is damaged. Contact your dealer.

Green status LED always
on (nonflashing);
Battery capacity level
indicator LEDs all OFF;
batteries won't charge

- Note: The charge indicator LED will be nonflashing green when the battery charger power is switched on, but should change to flashing battery status pattern when the batteries are charging.**
- Batteries not connected—connect batteries.
 - Battery terminals not connected—connect battery terminals.
 - Batteries not connected properly, or polarity reversed—correct connections.
 - Batteries severely discharged, below 1/2 volt—replace batteries.
 - Batteries defective—replace batteries.
 - Output fuse blown—check / replace the output fuse.

⚠ WARNING: Before checking the output fuse, disconnect battery charger from both power outlet and wheelchair battery charger receptacle.

- To check the output fuse:
1. Unscrew fuse, shown in picture at right, in direction of arrow.
 2. Replace with same size and type.

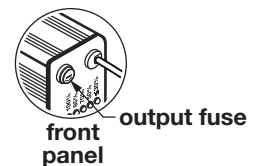

⚠ WARNING: Do NOT replace the output fuse with the AC fuse. They have different fuse ratings, and interchanging them could result in fire.

Contact your Graham-Field Health Products dealer.

SYMPTOM	CHECK—ACTION
Green status indicator LED flashes 1/2 second on 1/2 second off	FAST CHARGE mode automatically selected by battery charger. Continue to charge batteries until battery capacity level indicator yellow 100% LED illuminates.
Green status indicator LED flashes 2 times, then 2 seconds off	DEEP CHARGE mode automatically selected by battery charger. This indicates that the batteries have been severely discharged. Continue to charge batteries until battery capacity level indicator yellow 100% LED illuminates.
Green status indicator LED flashes 2 seconds on, 2 seconds off	FLOAT CHARGE mode automatically selected by battery charger. Batteries are nearly charged. Continue to charge batteries until yellow 100% LED illuminates.
Green status indicator LED flashes 4 times, then 1 second on, 1 second off	MAINTAIN CHARGE mode automatically selected by battery charger. Batteries are charged.
Battery capacity level indicator ≤35% red LED illuminates	Batteries are 35% or less charged. Continue to charge batteries until battery capacity level indicator yellow 100% LED illuminates.
Battery capacity level indicator 50% red LED illuminates	Batteries are 50% or less charged. Continue to charge batteries until battery capacity level indicator yellow 100% LED illuminates.
Battery capacity level indicator 70% yellow LED illuminates	Batteries are 70% or less charged. Continue to charge batteries until battery capacity level indicator yellow 100% LED illuminates.
Battery capacity level indicator 85% yellow LED illuminates	Batteries are 85% or less charged. Continue to charge batteries until battery capacity level indicator yellow 100% LED illuminates.
Battery capacity level indicator 100% yellow LED illuminates	Batteries are 100% or charged. Battery charging is complete. Turn battery charger power off and remove battery charger output connector from hand control receptacle.

Note: *If you experience a problem with your battery charger and are unable to service it yourself, contact the dealer from whom you purchased the wheelchair. If the dealer is unable to help you, contact our Customer Service Department for a list of qualified Graham-Field Health Products dealers in your area.*

X LIMITED WARRANTY

This warranty has been drafted to comply with the U.S. Federal Law applicable to products manufactured after July 4, 1975. This warranty is extended only to the original purchaser/consumer or dealer/non-consumer and to no other purchaser or transferee. GF Health Products, Inc. warrants the Everest with Captain Seat against manufacturing defects in materials and workmanship as listed below:

	WARRANTY PERIODS		
	6 mo.	1 yr.	5 yrs.
EVEREST CAPTAIN SEAT MODEL POWER WHEELCHAIR			
a) Base frame and seat frame.....			✓
b) Motors, controller, hand control, cables.....		✓	
c) Upholstered components, plastic parts, painted surfaces, rubber parts, bearings, front rigging, forks and any other parts not specifically identified above (all models).....	✓		
BATTERY CHARGERS		✓	
REPLACEMENT PARTS*	3 mo.	6 mo.	
a) Sideframe, mainframe, crossbraces, cross struts.....		✓	
b) New—motors, actuators, control module, hand control.....		✓	
c) Remanufactured—motors, actuators, control module, hand control.....	✓		
d) All other components.....	✓		

* The average life expectancy of a wheelchair under normal everyday use is approximately five (5) years.

** The warranty period is as designated above. If a part is replaced under warranty, the original warranty period will not be affected. All other replacement parts will be subjected to the warranty period specified.

The Warranty period for the consumer commences on the first date a product is delivered to consumer by seller/dealer. If the product is rented or leased, the warranty period commences on the invoice date from GF Health Products, Inc. A copy of the invoice showing date of purchase must be provided when submitting warranty claims. When proof of purchase date is not provided, warranty coverage shall commence upon GF Health Products, Inc.'s invoice date to the dealer/purchaser.

If within the warranty period, the product or component part is proven to GF Health Products, Inc.'s satisfaction to be defective, GF Health Products, Inc. shall provide, at its option, one of the following: (1) repair or replacement of any defective or nonconforming part or product or (2) a credit and/or refund of the original selling price made to GF Health Products, Inc.'s initial customer on a prorated or depreciated basis. GF HEALTH PRODUCTS, INC.'S SOLE OBLIGATION AND YOUR EXCLUSIVE REMEDY UNDER THIS WARRANTY SHALL BE LIMITED TO SUCH REPAIR, REPLACEMENT, CREDIT AND/OR REFUND. This warranty does not include any labor charges incurred in replacement part(s) installation or any associated freight or shipping charges to the manufacturer.

LIMITATIONS AND EXCLUSIONS: The foregoing warranty shall not apply to serial numbered products if the serial number has been removed or defaced. Products subjected to negligence, abuse, misuse, improper operation, improper maintenance, improper cleaning, improper storage, or damages beyond GF Health Products, Inc.'s control are not covered by this warranty, and that evaluation shall be solely determined by GF Health Products, Inc. This warranty shall not apply to problems arising from normal wear and tear or failure to follow instructions. The warranty shall also not apply to products modified without GF Health Products, Inc.'s express written consent; nor shall it apply if parts

not manufactured by GF Health Products, Inc., or if parts not complying with original equipment specifications are added to GF Health Products, Inc. products, or if the product or part is serviced by an entity not authorized by GF Health Products, Inc.

THE FOREGOING WARRANTY IS EXCLUSIVE AND IN LIEU OF ALL OTHER EXPRESS WARRANTIES AND IMPLIED WARRANTIES, INCLUDING BUT NOT LIMITED TO THE IMPLIED WARRANTIES OF MERCHANTABILITY AND FITNESS FOR A PARTICULAR PURPOSE, AND SHALL NOT EXTEND BEYOND THE DURATION OF THE EXPRESS WARRANTY PROVIDED HEREIN, AND THE REMEDY FOR VIOLATIONS OF ANY IMPLIED WARRANTY SHALL BE LIMITED TO THE REPAIR, REPLACEMENT, CREDIT AND/OR REFUND OF THE DEFECTIVE PRODUCT OR PART PURSUANT TO THE TERMS CONTAINED HEREIN. GF HEALTH PRODUCTS, INC. SHALL NOT BE LIABLE FOR ANY CONSEQUENTIAL OR INCIDENTAL DAMAGES WHATSOEVER.

This warranty gives you specific legal rights and you may also have other legal rights which vary from state to state (province to province). Some states (provinces) do not allow the exclusion or limitation of incidental or consequential damage, or limitation on how long an implied warranty lasts, so the above exclusion and limitations may not apply to you.

For warranty service, please contact the authorized dealer from whom you acquired your GF Health Products, Inc. product. In the event you do not receive satisfactory warranty service, please contact GF Health Products, Inc. at the address on the back cover. Do not return products to our factory without prior authorization. This warranty contains the entire agreement between the parties and supersedes any prior, contrary or additional representations or understandings, whether oral or written, concerning our warranty policy.

XI INDEX

A

Adjustments 15
Anti-tippers, check 36
Arm—controls 15
Arm height, adjust 17
Arms, check 36
Arm space from seat frame, adjust 17

B

Back 18
Back, fold down 18
Back angle, adjust 18
Balance 9
Batteries 24
Batteries, charging 27
Batteries, install 29
Batteries, remove 28
Battery charger 25
Battery charger, troubleshooting 43
Battery charger back panel 25
Battery charger front panel 25
Battery charger status display 41
Battery life, extending, guidelines 24
Battery maintenance, regular 31
Battery terminals, clean 37
Bearings, check 37

C

Cable connections, control system, FWD 34
Cable connections, control system, RWD 35
Cables and connections, check 33
Caster forks, check 37
Caution, significance 3
Circuit breaker, location 14
Controller 12
Controller, check 36
Controller diagnostic guide, general 40
Cowl 22
Cowl, install 22
Cowl, remove 22
Curbs and steps 10

D

Drive engagement levers 14

E

Electromagnetic interference 7
EMI warnings 8

F

Footplate extension length, adjust 23
Footplates, flip up 23
Footrests, check 36
Frame, clean 36

G

Getting started 11

H

Hand control 12
Hand control extension, adjust 15
Handling tips 9
Headrest 19
Headrest height, adjust 19

I

Introduction 3

J

Joystick, check 33

L

Limited warranty 45

M

Maintenance 32
Maximum weight capacity 3
Motor brushes, inspect 37

N

Note, significance 3

O

Operating instructions 14

P

Park brakes, check 36
Power drive system 11

R

Ramps and Inclines 10
Range with U1 batteries 11
Reaching / bending 9

S

Safety, charging the batteries 26
Safety precautions 4
Seat 20
Seat, install 20
Seat, remove 20
Seat height, adjust 21
Serial number location 38

T

Tires, check 36
Tools, adjustment, list 15
Tools, maintenance, list 33
Transfer activities 9
Troubleshooting 38

W

Warning, significance 3
Warnings 4
Warranty, limited 45
Width between arms, adjust 17

Everest & Jennings®

A Graham-Field Brand

U.S.A., Corporate Headquarters:

Graham-Field Health Products

2935 Northeast Parkway

Atlanta, Georgia 30360

telephone: 800-347-5678, 770-447-1609

fax: 800-726-0601, 678-291-3232



www.grahamfield.com

**Everest & Jennings, GF, and Graham-Field are registered trademarks,
and Everest is a trademark, of GF Health Products, Inc.**